

# DeltaPix InSight - Manual and Help

## USERS MANUAL

v6.7.2



Document processed : 05/07/2022 - 09.57

DeltaPix Support makes no warranties as to the accuracy of the information contained in this document or its suitability for any usage.

The information in this document is subject to change without notice.

Copyright © 2002 - 2022 DeltaPix Support. All rights reserved

# Table of Contents

Foreword	0
<b>Part I Introduction</b>	<b>9</b>
<b>Part II x64 - Limitations</b>	<b>10</b>
<b>Part III Software Installation</b>	<b>10</b>
1 System Requirements .....	10
2 Sequence to Install the Software .....	10
<b>Part IV Quick System Setup - Wizard</b>	<b>11</b>
<b>Part V Software Quick Guide</b>	<b>15</b>
1 System Settings .....	16
2 Control Panel .....	16
Language and user interface style selection .....	16
Options .....	17
Use HD as image memory.....	18
Ask for correct Magnification.....	18
Allow memory garbage collection.....	18
Save Image Quality ***** .....	19
Embed DPI info when saving images.....	19
Microsoft Word image quality.....	19
Allow Camera Optimization.....	20
Prefer RGB gain .....	21
Disable hardware acceleration of 3D graphics .....	21
Password.....	21
Monitor size .....	21
Dongle programming .....	21
Dongle programming – Drag and drop. ....	22
3 Dock Bars .....	22
4 Quick Access Toolbar (QAT) .....	23
5 The Galleries .....	24
6 The Progress Bar .....	25
7 Free Memory Indicator .....	25
8 Show Absolute or Relative magnification .....	25
9 Joystick control .....	27
<b>Part VI Camera Control</b>	<b>29</b>
1 Live Preview .....	29
2 Camera Control .....	30
Camera cooling .....	30
3 Light .....	32



<b>4</b>	<b>Auto Exposure</b> .....	<b>33</b>
<b>5</b>	<b>Colour</b> .....	<b>33</b>
	Colour Balance – Global .....	33
	Colour Balance – Area .....	33
	Colour correction .....	34
	For Infinity X, Infinity X32 and the DP cameras.....	34
	For Invenio and Invenioll Cameras.....	35
	For Inveniolll Cameras .....	35
<b>6</b>	<b>Preview Histogram</b> .....	<b>37</b>
<b>7</b>	<b>Using Properties from an Image Stored in a Gallery</b> .....	<b>37</b>

## **Part VII Still Image Capture** **37**

<b>1</b>	<b>Capture Still Image</b> .....	<b>38</b>
	Insert Scale Bar .....	38
	Crop Image .....	38
	Easy save .....	40
	Reset Image Counter .....	41
	48 Bits per Pixel Mode .....	41
	Insert Crosshair overlay .....	41
	Insert Calibrated Grid overlay .....	42
<b>2</b>	<b>Capture Image Using the Snapshot Mode</b> .....	<b>42</b>
<b>3</b>	<b>Save Image</b> .....	<b>43</b>
	Image Saving in a Gallery .....	44
	Image Saving by Right-clicking the Image .....	44
	Image Saving using the Standard Menu .....	45
	Image Saving by Right-clicking a Gallery .....	45
	EXIF .....	45

## **Part VIII Calibration** **46**

<b>1</b>	<b>Defining the optical device and magnifications</b> .....	<b>49</b>
	Make the calibration private or shared .....	49
	Add an optical device .....	50
	Add an optical magnification .....	51
	Add a preferred exposure time for an objective .....	51
	Relative exposure.....	51
	Add a DOF for an objective .....	53
	Adding an information file .....	53
	Defining camera- integrated focus controller Z-calibration .....	54
	Calibrating the focus controller and definition in the optics definition editor.....	56
	Defining field curvature compensation .....	61
<b>2</b>	<b>Calibrate One Objective</b> .....	<b>63</b>
	Calibration slider .....	63
	Select the device and magnification to be calibrated .....	64
	Draw calibration ruler .....	64
	Calibrate to real world metrics .....	64
<b>3</b>	<b>Calibrate a Camera and More Objectives</b> .....	<b>65</b>
<b>4</b>	<b>Calibrating a motorized zoom objective</b> .....	<b>65</b>
	Defining the Objective in the Optics Editor .....	65
	Associating the Description file .....	66
	Defining the Depth of Field .....	67

Calibrating the Objective .....	68
Motor Zoom - Virtual fixed objective positions .....	69
<b>5 Calibration overview .....</b>	<b>71</b>
<b>6 Calibration Backup and Restore .....</b>	<b>71</b>
Backing up the Calibration files .....	72
Restoring the Calibration files .....	74
<b>7 Scale Bar .....</b>	<b>75</b>
<b>8 Walton and Beckett graticule .....</b>	<b>75</b>
<b>9 Calibrating a motorized Zeiss MTB zoom objective .....</b>	<b>76</b>
Defining the microscope .....	77
Defining the microscope magnification .....	78
Calibrating the motorized objective .....	79
Controlling the microscope .....	80
<b>10 Sharing Calibrations .....</b>	<b>80</b>
For the user with a complete calibration .....	81
Copy the calibration to another user .....	82
<b>Part IX The Home Tab .....</b>	<b>83</b>
<b>1 The Editing Tools .....</b>	<b>83</b>
<b>2 The Formatting Tools .....</b>	<b>83</b>
<b>3 Reporting .....</b>	<b>83</b>
Realize .....	84
Excel Report .....	84
Sample Excel Report template.....	85
Sample Excel Report output.....	87
PDF Report .....	89
Comma Separated Value Report .....	89
Exporting CSV data to Microsoft Excel .....	89
The Comma Separated Value file.....	90
Import to Microsoft Excel 2007.....	91
<b>4 The Window tools .....</b>	<b>93</b>
<b>Part X The View tab .....</b>	<b>93</b>
<b>1 Image Tile .....</b>	<b>93</b>
<b>Part XI The Measurement and Annotation tab .....</b>	<b>94</b>
<b>1 Annotation .....</b>	<b>94</b>
<b>2 Measurement .....</b>	<b>95</b>
Polygon and Freehand result options .....	95
Circle measurement result options .....	95
Flexible position for measurement result .....	96
<b>3 Save the Annotations and Measurements .....</b>	<b>96</b>
Save and Open the Annotations only .....	96
Save the Annotations and Measurements in Seperate Files .....	97
Save the Annotations and Measurements in the Same File .....	97
<b>Part XII The Still Image Tab .....</b>	<b>97</b>

1 Undo .....	97
2 Remap Intensity .....	98
3 Fluorescence .....	99
4 Deconvolution – Lucy-Richardson algorithm .....	100
<b>Part XIII The Image Extender Tab</b>	<b>101</b>
1 Manual Extended Focus .....	101
2 Extended Exposure .....	102
Contrast post processing .....	103
3 Manual Extended Field .....	103
<b>Part XIV The Counting Tab [from v6.1.18]</b>	<b>105</b>
1 Workspace .....	106
2 Phase Segmentation .....	107
Pick object color .....	107
Phase Definition Overlap .....	108
3 Morphology preprocessing .....	108
4 Area Feature .....	108
5 M1 Feature .....	108
6 Ferret Feature .....	109
7 Counting .....	110
Settings .....	110
Use same features.....	111
Counting Options .....	112
Create Table.....	112
Insert Count Label.....	113
Create New Image.....	113
Object index label.....	113
8 Reporting .....	113
Excel .....	113
Template tags .....	114
PDF .....	114
Excel processing – example calculating the Phase% .....	116
9 Manual Counting .....	116
<b>Part XV The System Automation Tab</b>	<b>117</b>
1 Stage Automation .....	117
Selecting and Configuring the Motor Controller .....	118
Prior Controller.....	118
Zeiss MTB.....	120
Ludl MAC5000/MAC6000 Controller .....	120
Märzhauser TANGO .....	122
DeltaStep4.....	124
Mitutoyo - MF.....	125
Mitutoyo - Insert Scale Bar.....	125
Mitutoyo - EXIF Information .....	126
Making the motor speed relative to the Magnification .....	126

Verifying the X and Y movement scheme .....	127
<b>2 Automatic Extended Field .....</b>	<b>128</b>
Automatic Extended Field with Extended Focus and Extended Exposure .....	129
<b>3 Automatic XYZ Acquisition .....</b>	<b>129</b>
Acquisition Options. ....	130
Define the target image directory. ....	131
The position table. ....	131
Defining Image Position macros in the 'Comment' field. ....	131
Defining Point Transformation macros in the 'Comment' field. ....	133
Table Macro programming .....	134
Table Macro Programming - Example code.....	139
<b>4 Focus automation .....</b>	<b>140</b>
<b>Selecting and Configuring the Motor Controller .....</b>	<b>141</b>
Prior Controller.....	141
Zeiss MTB.....	142
Ludl MAC5000/MAC6000 Controller.....	143
Märzhauser TANGO.....	146
DeltaStep4.....	147
Mitutoyo - MF.....	148
Mitutoyo - Insert Scale Bar.....	148
Mitutoyo - EXIF Information.....	149
ErgoFocus.....	150
Stand alone mode - parameters.....	152
ErgoFocus firmware versions.....	153
Camera with integrated focus control.....	153
<b>Automatic Extended Focus .....</b>	<b>153</b>
Setting the Number of Z-slices to be acquired. ....	154
Using the DOF from the Optics Editor.....	154
<b>Automatic Extended Focus with Extended Exposure .....</b>	<b>155</b>
<b>Auto Focus [from v6.6.7] .....</b>	<b>155</b>
One region Auto Focus.....	167
Global center weighted Auto Focus.....	168
One Region Auto Focus.....	168
Two region Auto Focus.....	169
<b>Making the motor speed relative to the DOF .....</b>	<b>171</b>
<b>5 Zoom Automation .....</b>	<b>172</b>
Zeiss MTB .....	172
DeltaStep4 .....	173
<b>Part XVI Accessories Tab .....</b>	<b>174</b>
<b>1 Zeiss microscope controls .....</b>	<b>174</b>
<b>2 Mettler Toledo Hot Stage HS82 .....</b>	<b>174</b>
<b>3 PixLight Ringlight (Valid from InSight 6.4) .....</b>	<b>176</b>
<b>4 Objective change scanning .....</b>	<b>178</b>
Example: Askania 6Z .....	179
<b>Part XVII Image Compare .....</b>	<b>180</b>
<b>Part XVIII Topography [from v6.4.0] .....</b>	<b>186</b>
<b>1 File .....</b>	<b>187</b>

Open .....	187
Save .....	188
<b>2 Topography .....</b>	<b>190</b>
Manual Topography .....	190
Automatic motorized Topography .....	191
Use Z range from previous topography .....	191
Parameters .....	192
<b>3 Compensation .....</b>	<b>192</b>
<b>4 3D View .....</b>	<b>193</b>
<b>5 3D Measurement .....</b>	<b>194</b>
3D Roughness .....	196
Abbot Firestone.....	197
<b>6 2D View .....</b>	<b>197</b>
<b>7 2D Measurement .....</b>	<b>198</b>
2D Roughness .....	199
2D Profile Measurements .....	200
<b>8 Reporting .....</b>	<b>203</b>
Template .....	204
<b>Part XIX Video recording [from v6.2.9] .....</b>	<b>204</b>
1 Recording frame rate .....	205
2 Playback frame rate .....	205
3 Recording time .....	206
4 Information .....	206
5 Recording .....	206
<b>Part XX Shortcuts and special Keys .....</b>	<b>207</b>
1 Special start-up modifier keys .....	209
2 Special shut-down modifier keys .....	210
3 Motor speed modifier keys .....	210
<b>Part XXI FAQ - Frequently Asked Questions .....</b>	<b>211</b>
1 Software freeze checklist .....	211
2 Installing Prior software .....	212
3 Understanding magnification .....	212
4 Get rid of old Invenio 3S/5S drivers .....	212
5 Install driver for For InvenioIIIeb Cameras .....	213
6 Disable Internet connectivity .....	216
7 Frame rate drops .....	217
8 Fix an Annoying Windows USB Power Problem .....	217
9 ATEN USB to RS232 converter driver .....	218
10 USB Cables .....	219
11 Graphics performance .....	219

12 A generic error occurred in GDI+ .....	220
---	-----

## Part XXII Appendix 220

1 Backup - Restore - Cloning .....	221
2 External Drive for Settings .....	225
Export Settings to External Settings Drive - Method 1 .....	226
Export Settings to External Settings Drive - Method 2 .....	227
Import Settings from External Settings Drive .....	229
3 Installing and connecting to Prior (OptiScanII) .....	232
Installation .....	232
64bit operating system .....	232
Prior OptiScanII Z-motor operation .....	232
4 TWAIN .....	233
5 DirectX (DirectShow) .....	233
6 Matlab .....	233
7 Installing and connecting to Zeiss MTB 2011 .....	234
Using another version of MTB2011 than the default MTB2011 version .....	234
Optics Editor and calibration hints .....	237
8 Märzhäuser TANGO .....	238
9 Mitutoyo MF - Communication Setup .....	239
10 Custom Camera Configuration .....	240
11 Artray ARTCAM-130XQE-WOM Camera .....	242
12 Artray ARTCAM-990 SWIRTEC camera .....	243
Artray ARTCAM-990 SWIRTEC - Driver installation .....	243
Artray ARTCAM-990 SWIRTEC - Basic setup .....	246
13 Allied Vision - GOLDEYE .....	249
14 Connecting H4KWS08DPX by WiFi .....	253
15 TEKLEAD Scanner .....	254
TEK_E1_CCD .....	256
TEK_E2_USB .....	256

## Index 257

# 1 Introduction



DeltaPix InSight is modern and easy to use software. It offers the best interface to DeltaPix cameras and makes advanced image acquisition easier than ever.

However, if you have problems installing or using the software or with general camera operation, you can e-mail our technical support group at [support@deltapix.dk](mailto:support@deltapix.dk) or contact your local dealer or distributor to get further direct support.

Please visit our homepage at [www.deltapix.dk](http://www.deltapix.dk) for software updates or other improvements for your DeltaPix camera and accessories.

v6.7.2 - Document processed : 05/07/2022 - 09.57

## 2 x64 - Limitations

DeltaPix InSight (from v.6.0.0) is 64bit only.  
This means, that it cannot be installed on 32bit computers.

Some cameras are no longer supported:

- DP 200
- Invenio 1D
- Invenio 3D
- Invenio 5D

Also the MicroSMC stepper motor controller is discontinued.

## 3 Software Installation

### 3.1 System Requirements

- Windows 7, Windows 8 or Windows 10 - 64 bit versions.
- A high resolution monitor is recommended, HD (1920x1080) or better.
- A fast CPU (like a Intel i5 or i7)
- A modern and fast graphics processor. Shared video memory is not recommended.
- At least 8 GB of RAM is recommended.
- At least 25 GB of free disk space
- USB 2.0 or 3.0 ports - it is not recommended to use USB hubs!

### 3.2 Sequence to Install the Software

- Detach any DeltaPix camera and dongle from your PC.
- Use the DeltaPix Installation Manual to install the new software package from your CD or from [www.deltapix.dk](http://www.deltapix.dk).
- Attach the dongle (Note: Most DeltaPix InSight versions require a dongle to run). If it is the first time the dongle is attached you should see a 'Found New Hardware' sequence. Wait for the sequence to complete. Later dongle attachments will issue the Windows " 'hardware attached' sound.
- Attach the camera. If it is the first time the camera is attached you should see a 'Found New Hardware' sequence. Wait for the sequence to complete. Later camera attachments will issue the Windows 'hardware attached' sound.



- Start the DeltaPix InSight software.

## 4 Quick System Setup - Wizard

The 'Quick System Setup' tool will automatically launch on the first run after the software is installed.

It allows for super fast configuration of all the motor parameters, XY, Focus and optional Zoom control – all just by selecting the system type (like e.g. 'AB 70S') and the communication COM port.

The factory calibration files are now also loaded via this tool.

The list of supported systems will be updated as needed.

**The 'Quick System Setup' can be launched manually at any time by shortcut Ctrl-Shift-W.**

The wizard launches the first time after installation of a new version.

If you haven't made any changes to attached hardware – and if you are happy with the current setup – click 'cancel'

To continue the Quick System Setup, click 'Next'.

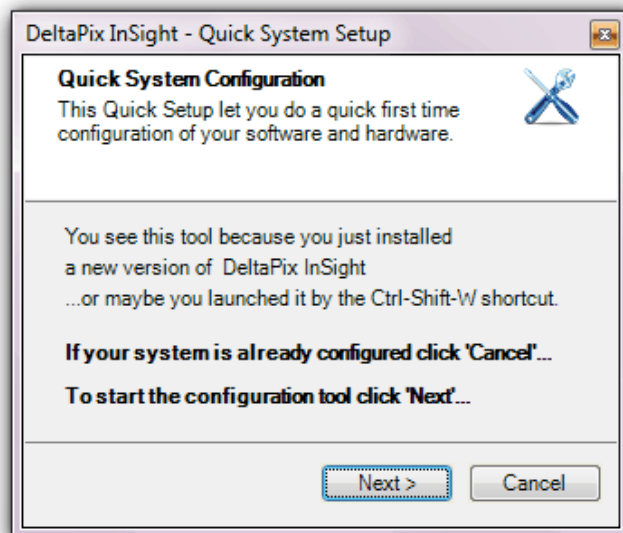

If you have a backup, cloning is the easiest way to set up your DeltaPix InSight.

If you don't have a backup, skip this step by 'Next'.

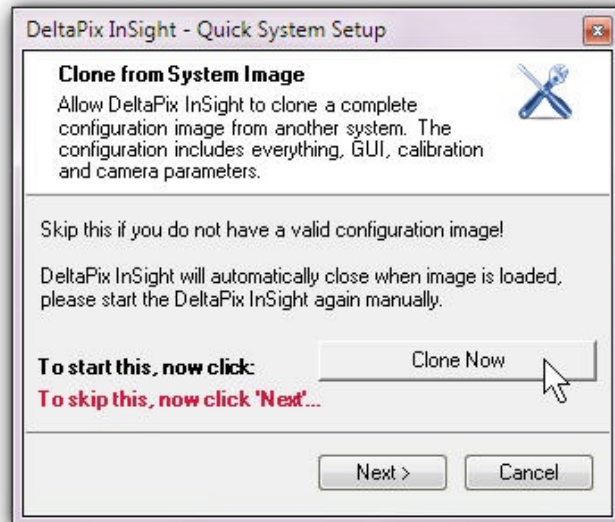

See also: [Backup - Restore - Cloning](#)

Select your system.

If your hardware is not listed, click 'Cancel'.

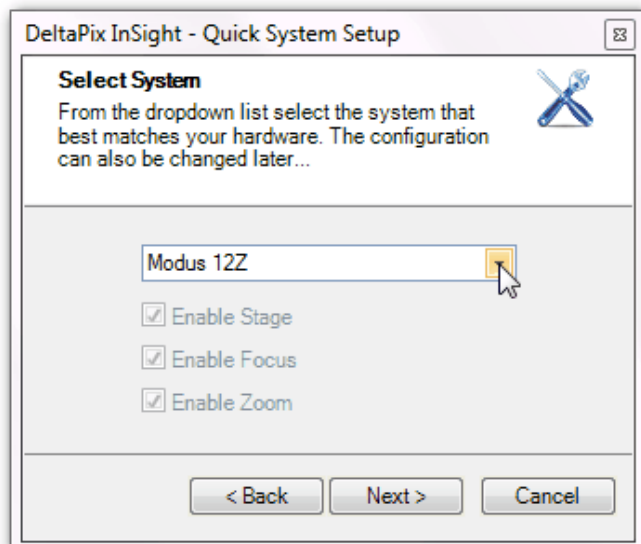

DeltaPix InSight can check for new software releases and other news from DeltaPix.

On some computers with tight security settings, this may cause troubles.

If in doubt contact your IT department, or simply disable the DeltaPix InSight internet connectivity.

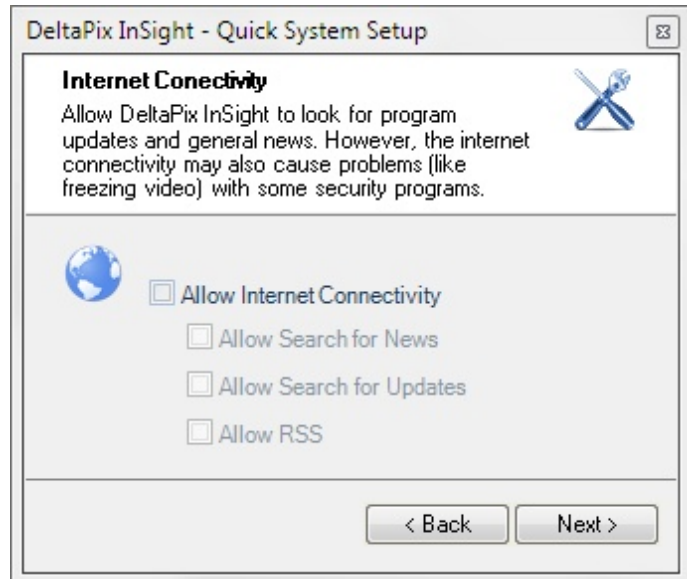

Some systems communicate via a COM port – now select the associated COM port, and click 'Next'.

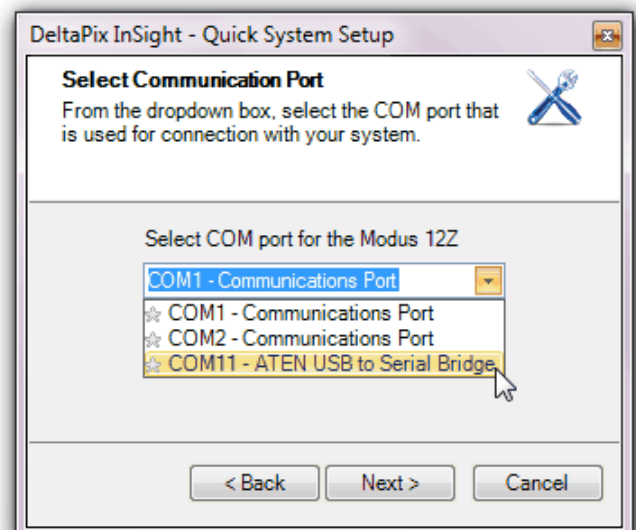

If you have calibration files, check the check box, then click 'Next'.

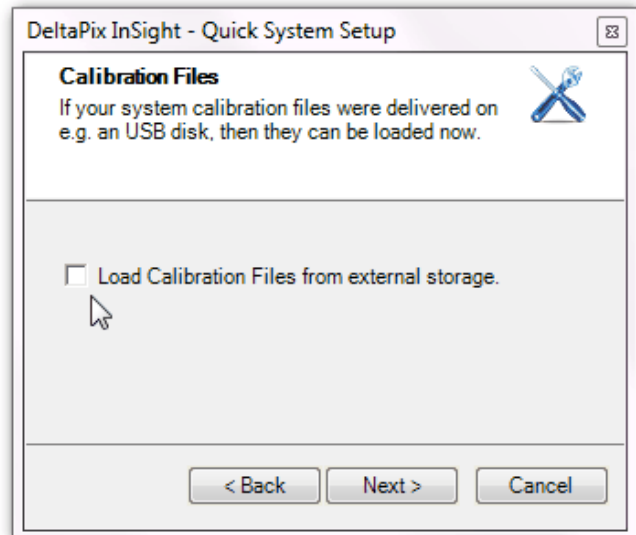

All done...

When everything is set up, DeltaPix InSight may have to restart to make the settings take effect.

You will have to manually launch the program afterwards.

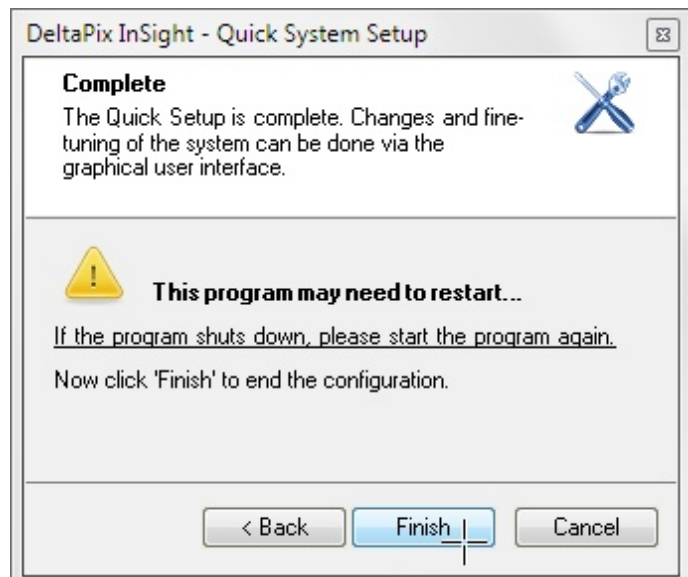

## 5 Software Quick Guide

This is an overview of the GUI with outlines of the basics:

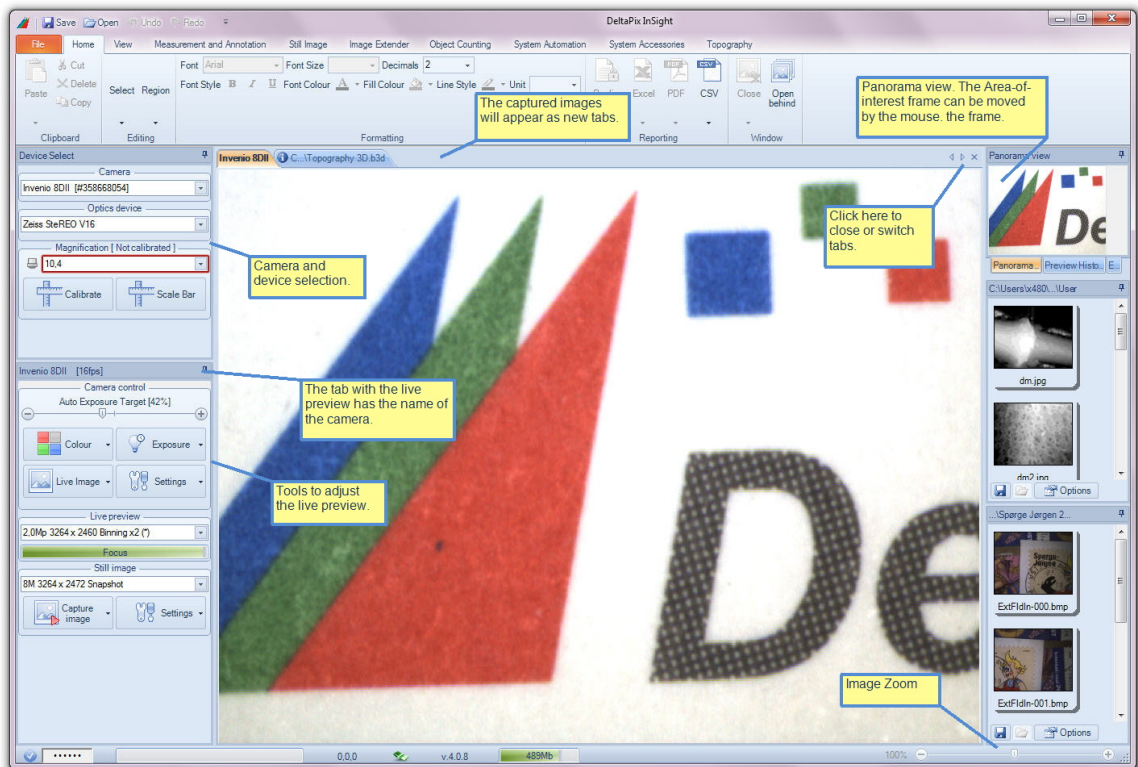

DeltaPix InSight has a modern and intuitive user interface based on the ribbon band style known from Microsoft Office. Version 2007 and 2010 of the Microsoft Office and the Visual Studio 2010 style is supported by the software.

Functionalities are grouped logically and the program is easy to use.

Features are:

- Camera panel for fine-tuning of all camera parameters e.g. exposure, gain, and more
- Device panel for selection of camera and optics
- Panorama view for easy image manoeuvring in zoomed live and still images
- Multiple image galleries with thumb view
- Easy storage of images

## 5.1 System Settings

The upper-left button in the GUI opens a 'standard' office drop-down menu, allowing:

- File open
- File save
- Printing
- E-mailing
- Online manual (this manual, latest version)

The **System Maintenance** button opens functions used seldom, e.g.:

- Optics definition editor
- Control Panel
- On line list of known software issues
- About

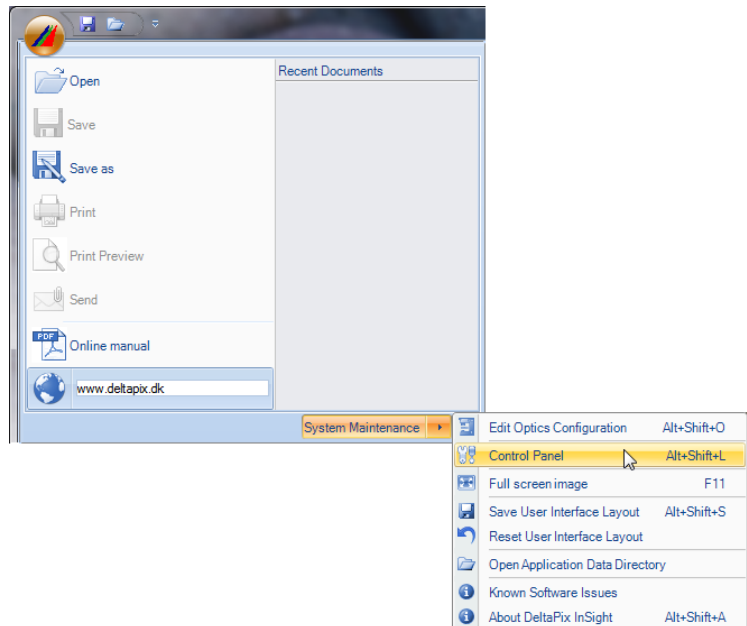

## 5.2 Control Panel

The control panel hosts general application settings.

### 5.2.1 Language and user interface style selection

Language can easily be switched. More than ten languages are supported.

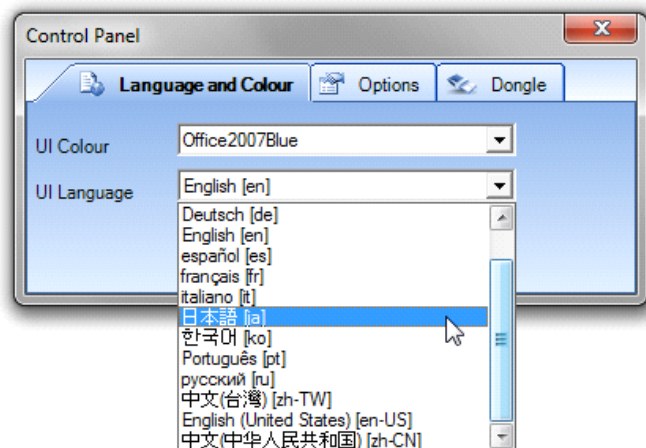

InSight can appear in a variety of modern styles, select your preference among Office2007, Office2010 or 'Visual Studio' styles.

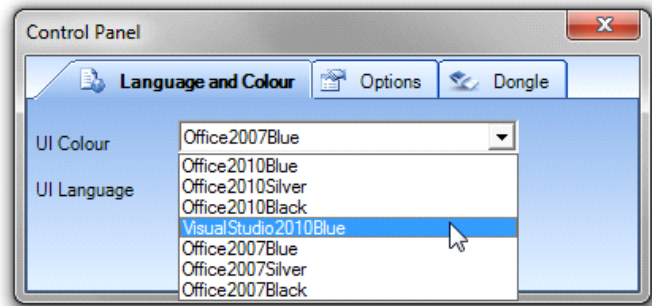

## 5.2.2 Options

The option panel allows setting of lower level options.

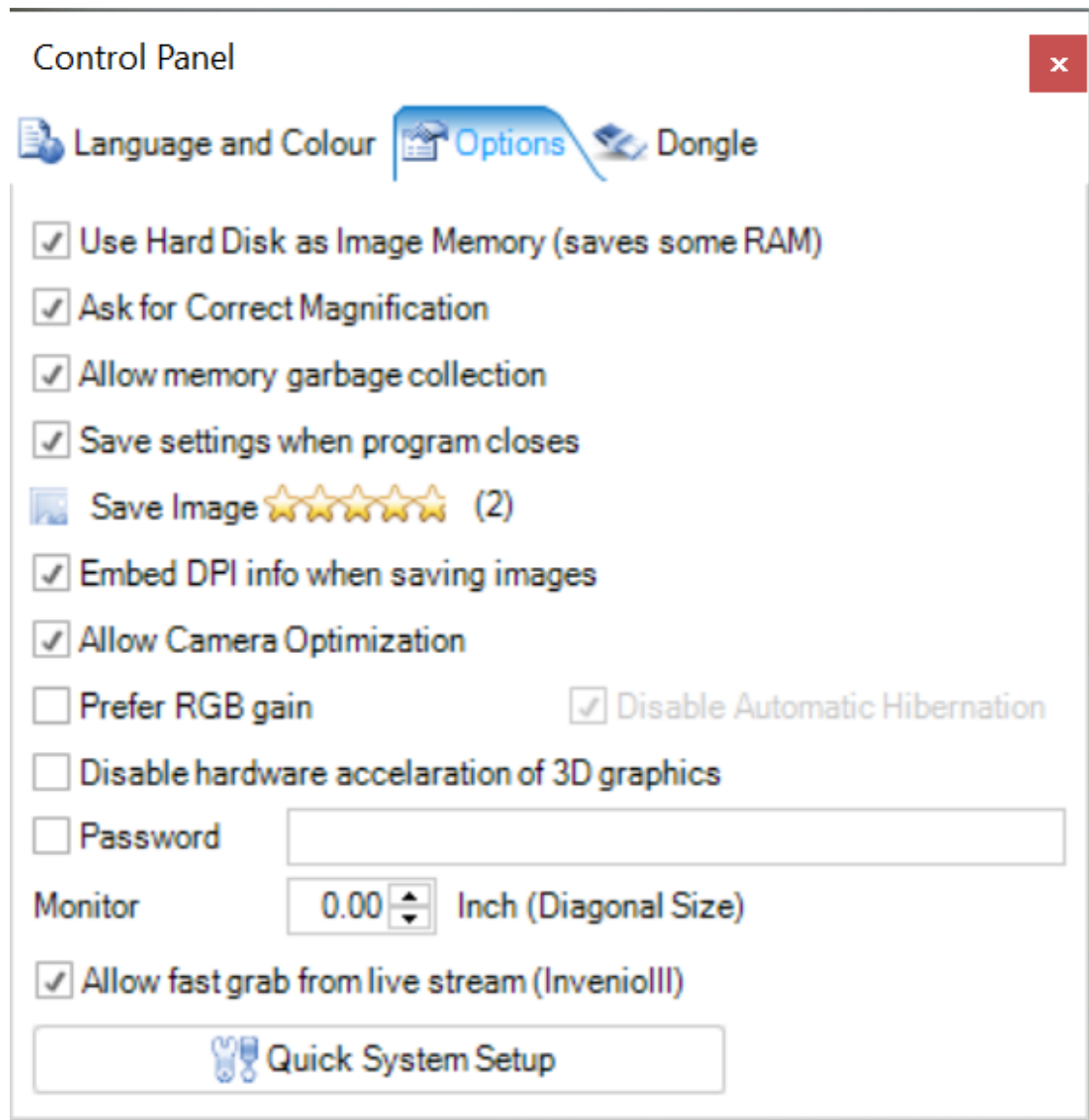

#### 5.2.2.1 Use HD as image memory

It saves RAM to use this option - it also however slows some image operations slightly. It is highly recommended to use this option if a fast HD is available.

#### 5.2.2.2 Ask for correct Magnification

When using a system with manual magnification change - such as a objective carousel without feedback, this option is recommended.

It will prompt "Is correct magnification selected" in the software. This ensures that calibration is always correct, and measurements are reliable.

#### 5.2.2.3 Allow memory garbage collection

This option often makes the use of system memory more efficient.

On some special computers, especially Windows XP computers, this option may cause problems.



#### 5.2.2.4 Save Image Quality \*\*\*\*\*

The global image save quality sets the image compression factor.  
The image compression factor (2-100) is shown in the parenthesis.



The quality is selected by clicking on a star.

**It is strongly recommended to use the 5 star setting (compression lowest = 2)**

#### 5.2.2.5 Embed DPI info when saving images.

If captured images are to be imported in e.g. Microsoft Word, high magnification images (i.e. a huge DPI), will appear very small. Uncheck this to avoid true embedded DPI.

##### 5.2.2.5.1 Microsoft Word image quality

Word tries to reduce the resolution to file footprint smaller. You may need to tell it not do to that.

Go to File / Options / Advanced / Image Size and Quality. Check the box that reads Do Not Compress images in file. Here's how it looks:

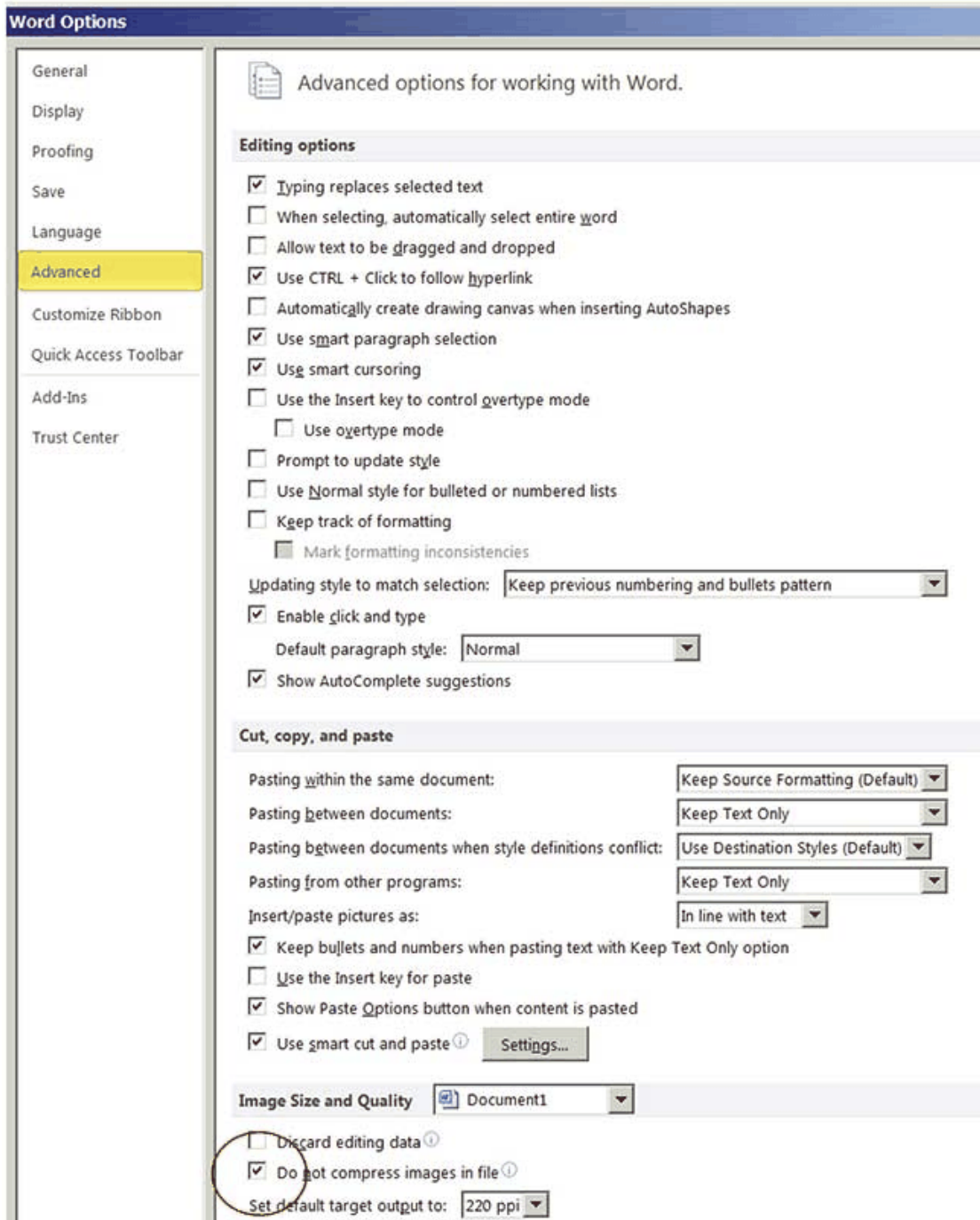

### 5.2.2.6 Allow Camera Optimization

Some types of cameras - mostly CMOS cameras may benefit from this pixel optimization. Poor pixels are detected, and will be corrected/compensated to achieve the optimum still image quality.

### 5.2.2.7 Prefer RGB gain

The option sets the preferred way of adjusting the image colors. By clicking "Prefer RGB gain" the control is done by RGB sliders, otherwise by Temp/Tint sliders.

Temp/Tint is the default, although not all supported cameras support this. Cameras that does not support Temp/Tint will automatically revert to RGB control.

**Changing this value may require the camera to reconnect, or to restart the DeltaPix InSight**

### 5.2.2.8 Disable hardware acceleration of 3D graphics

It is possible to disable hardware acceleration of 3D rendering. This will slow down all 3D operations. It is highly recommended to always use hardware acceleration of 3D graphics.

**NOTE: Some Intel GPU's fail to work with DeltaPix InSight and hardware acceleration - in these rare cases it may become necessary to disable the hardware acceleration.**

### 5.2.2.9 Password

A password can be entered to protect vital settings like the system calibration and motor controller configurations. This will in many cases protect against unwanted tampering.

### 5.2.2.10 Monitor size

What exactly is magnification? A basic definition of magnification is the ratio of the size of a specific feature of an object or sample as seen in an image produced by an optical system to the actual size of the feature on the object itself.

In digital imaging this can be defined as the ratio between the size of the object as shown on the monitor and the actual physical size of the object.

So in order to display the correct magnification, the size of the monitor also must be known.

## 5.2.3 Dongle programming

A DeltaPix dongle can be updated with new features. Load the dongle file, and push the program button.

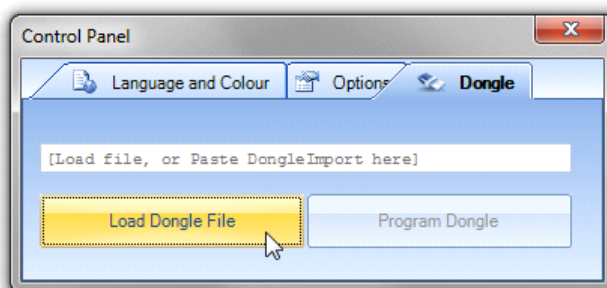

### 5.2.4 Dongle programming – Drag and drop.

Another – and easy way to reprogram a dongle is simply to drag the dongle programming file into the DeltaPix InSight' program icon.

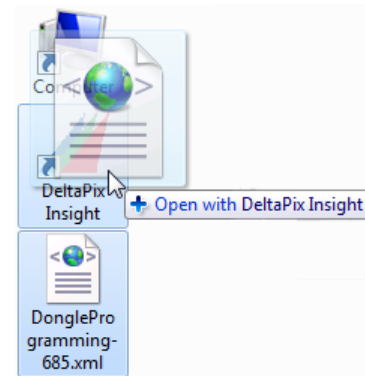

## 5.3 Dock Bars

The program uses the concept of document docking. This allows the dock bars to be hidden or showed at fixed locations.

To hide the dock bar click the pin.

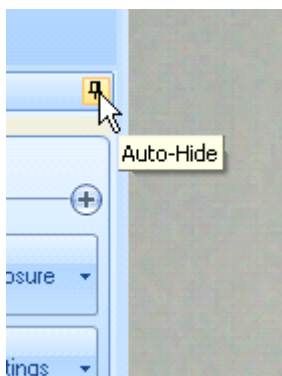

To view, move the cursor to the tab.



To show the dock bar click the pin again.

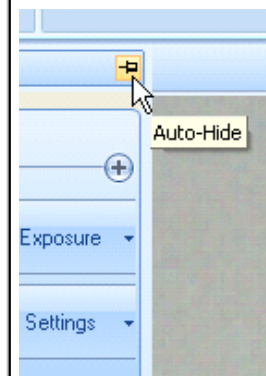

It is also possible to move and rearrange the dock bars to other locations in the GUI.

To move a dock bar on top of another dock bar simply drag the dock bar and place it on the top spot of the cross. This is shown in the figure below:

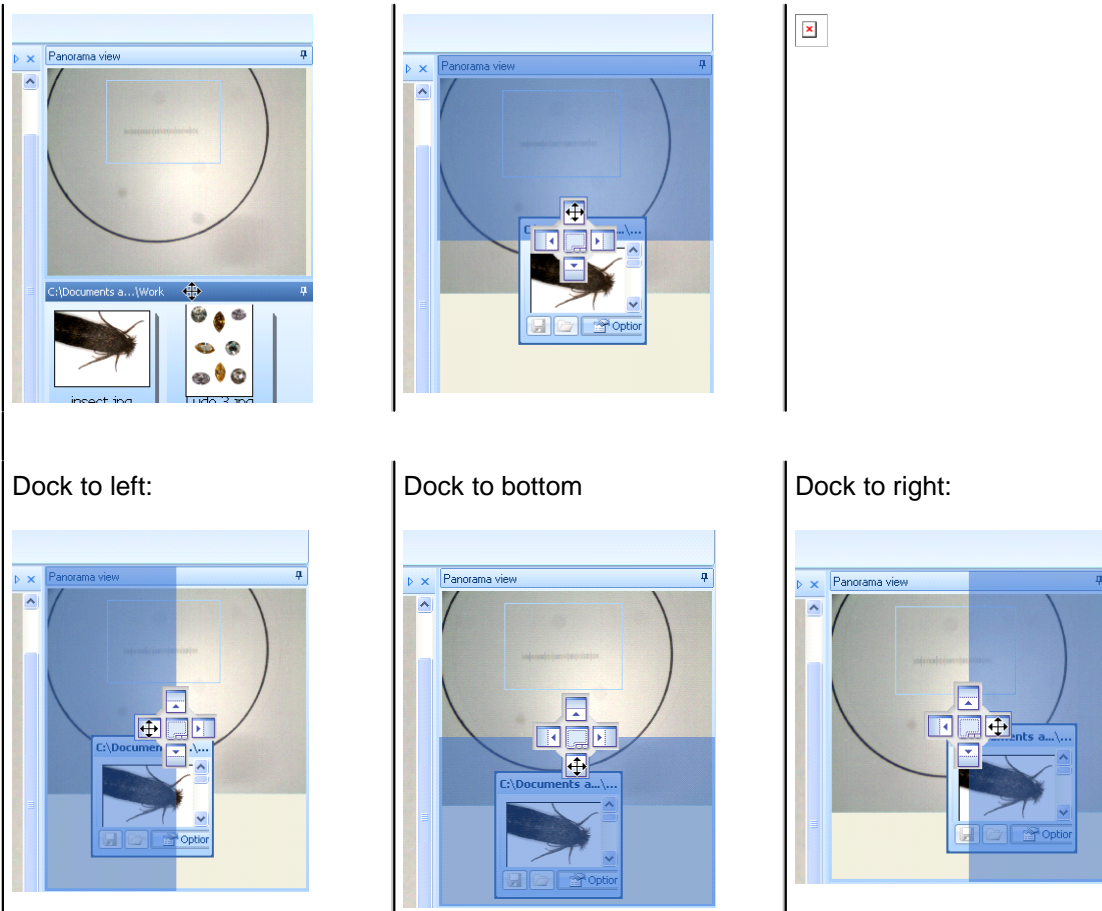

Docking may seem complicated and confusing – it is however a nice feature. If it ends up in a mess you can always select **Reset user interface layout** in the **System Maintenance** menu. Saving a layout is also done from the **System Maintenance** menu.

## 5.4 Quick Access Toolbar (QAT)

The Quick Access Toolbar is a customizable toolbar which contains a set of commands, that are independent of the tab displayed currently. You can move the Quick Access Toolbar from one of the two possible locations, and you can add buttons that represent commands to the Quick Access Toolbar.

The QAT can be minimized to save screen area.  
The QAT can also be placed below the ribbon bar.

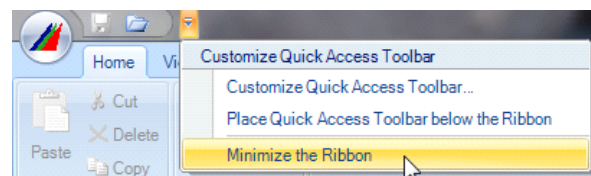

A button – or other control – can be mirrored to the QAT.  
 Right-click the command and then click **Add to Quick Access Toolbar** in the shortcut menu.  
 In this example it is shown how to add one of the motor control arrow buttons to the QAT.

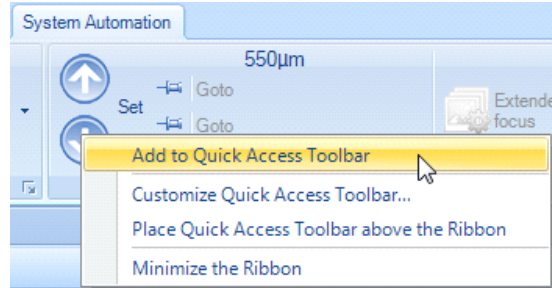

This example shows:

A minimized ribbon.

The QAT placed below the ribbon

Two arrow (Focus Motor up/down) added to the QAT.

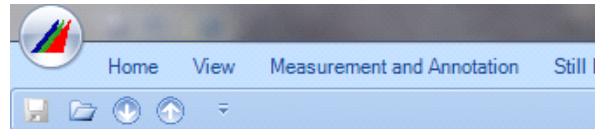

## 5.5 The Galleries

InSight has two image galleries.

Images can be dragged from the the galleries to the image area to open an image.  
 Images can be dragged and dropped in between the galleries. Images can also be dragged to the 'Extended Field' editor.

Images stored in the gallery can easily have their properties copied back to a camera – see section 'Using properties from an image stored in a gallery'.

### NOTE:

**Loading thumbnails requires computational resources, and may take some time.**

**To prevent unintended motor control, all motor control is disabled while thumbnails are loading**

**A notification will show this state.**

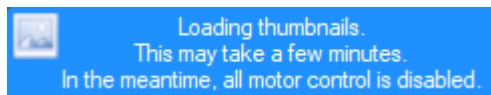

## 5.6 The Progress Bar

For lengthy operations, the progress bar shows the progress of the current operation.

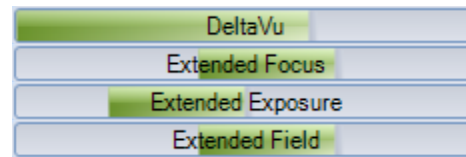

## 5.7 Free Memory Indicator

Some operations require a lot of free (and un-fragmented) memory. Usually the memory indicator is not visible – which indicates that there is plenty of free memory. A green indicator shows the remaining free memory. Yellow or red indicators also show free memory, but indicate that InSight is running short of memory.

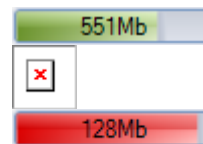

## 5.8 Show Absolute or Relative magnification

If in 'Relative Magnification Mode' the slider text shows the digital zoom percentage.

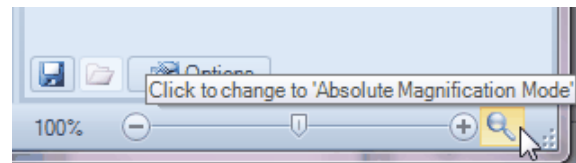

Click the small magnifier button to switch to 'Absolute Magnification Mode'.

If in 'Absolute Magnification Mode' the slider text shows the magnification value.

Click the small magnifier button to switch to

'Relative Magnification Mode'.

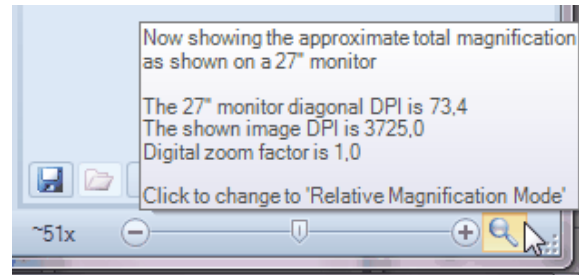

The magnification depends on the monitor used for display – the larger monitor, the larger magnification.

The monitor size defaults to 27" – but can be changed in the control panel.

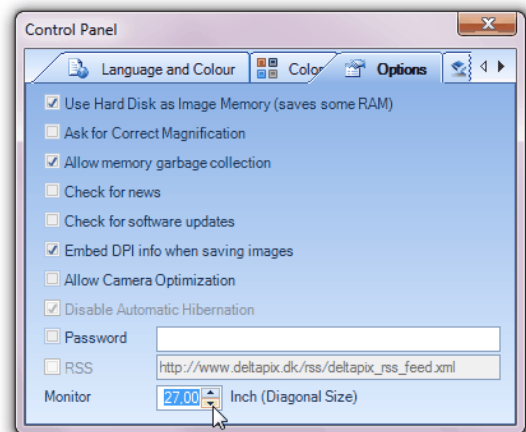

The magnification is calculated as:  $\text{Magnification} = \frac{\text{DigitalZoom} \times \text{ImageDPI}}{\text{MonitorDiagonalDPI}}$

If the magnification shown is 1 – then an image of (approximately) the camera sensor size is displayed.

NOTE: The objective must be correctly calibrated to have the correct magnification readout.

NOTE: Depending on the resolution setup of your monitor, the pixels on your monitor are not necessarily square – in this case the magnification shown is only approximate.



## 5.9 Joystick control

If your software supports joystick control - then in the status line there a small joystick button is shown.



The X, Y, F indicates that the 3 axis joystick controls X and Y position and Focus.

Alternatively X, Y and Zoom can be controlled – then the text will be X, Y, Z.

Double click the button to configure the (optional) 6 buttons on the joystick.

A panel will pop up – each button function can be selected.

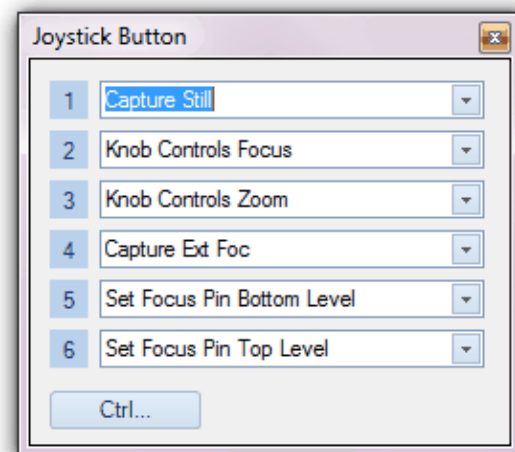

An example of setting the function for button 5.

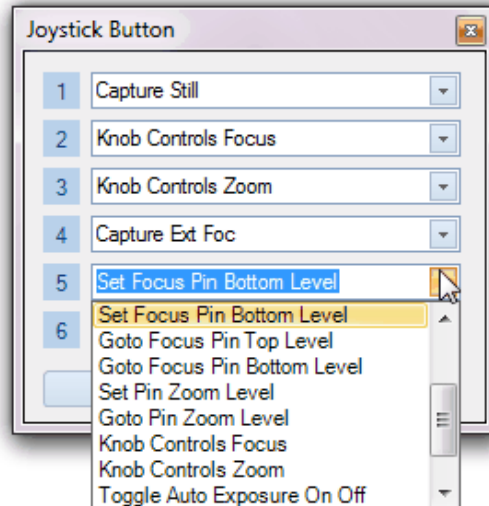

When mouse hovering the button a balloon will show the current button configuration.



**Most standard HID joysticks will work.**

A recommended joystick is RS



## 6 Camera Control

### 6.1 Live Preview

With DeltaPix InSight it is possible to connect multiple cameras at the same time, and switch from one camera to another. All DeltaPix cameras are supported.



Other cameras with a DirectShow interface are also supported. However, this requires the DirectShow feature to be enabled in the dongle.

Selecting the camera is done in a drop down menu as shown here.

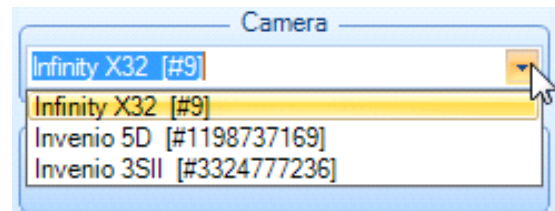

## 6.2 Camera Control

Use the adjustment tools to adjust the live preview to the desired quality.

The settings drop down allows fine-tuning of all camera parameters.

Note that the options shown depend on the camera type. Not all cameras have all types of controls.

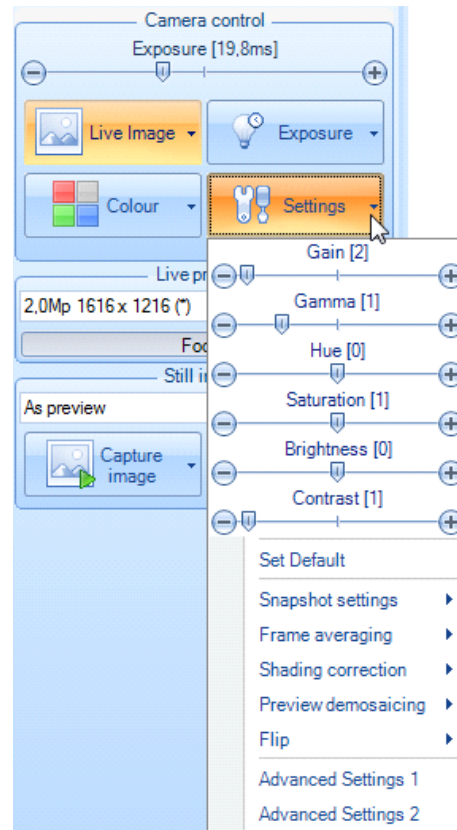

### 6.2.1 Camera cooling

If the camera supports sensor cooling - then the properties drop down will allow setting of a target temperature, and optionally selecting fan on/off

This is a description of the DeltaPix COOL07DPX, COOL09DPX and COOL20DPX camera cooling user interface in DeltaPix InSight.

In the Settings drop down, find the new properties related to the TEC cooling.

Camera cooling can be set on/off by the "Camera Cooling" check-box.

Camera fan can be set on/off by the "Fan" check-box.

The numeric text box defines the target temperature for the TEC cooling.

Please note that the cooling cannot be set on if the "Fan" is off.



In the bottom status bar, the cooling status is shown. This shows the actual temperature.

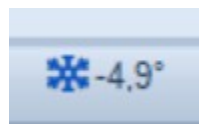

Hint: The proprietary “convert gain to exposure” feature can be used with these cameras.

Use high gain in the preview to have fast live preview and convert this to exposure time when capturing still images. Please be aware that when using very high gain, this may convert to very long exposure time. Example if the gain is 100x and the exposure is 500ms, then the exposure time will be 50secs. On top of this ~3 images are acquired – so the overall

acquisition may become long.

Cameras are good quality, with very few hot pixels.

Anyway, if any occur, then the “Auto Fix Hotspots” can be used.

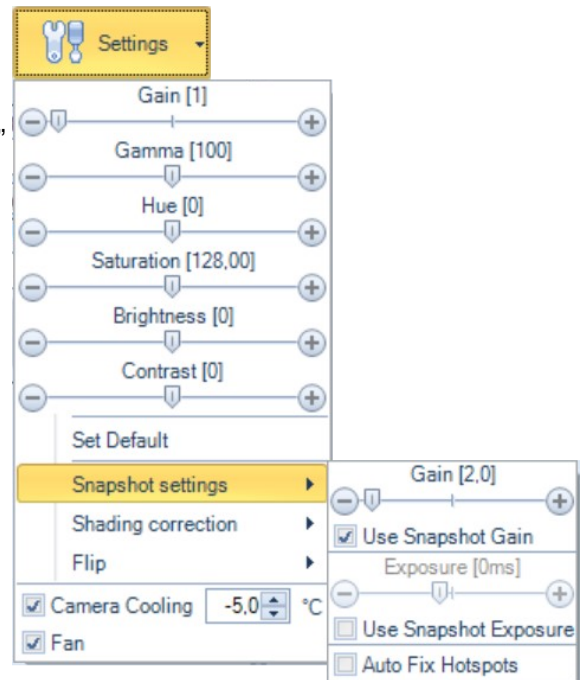

## 6.3 Light

To avoid flickering and horizontal lines when using older AC light sources, set the **Light source frequency** to the frequency of the light source; 50 or 60 Hz.

Using this option will limit the lowest possible exposure time to 1/100 or 1/120 second.

Hence, in case that the light level is too high, the light level must be decreased on the light source.

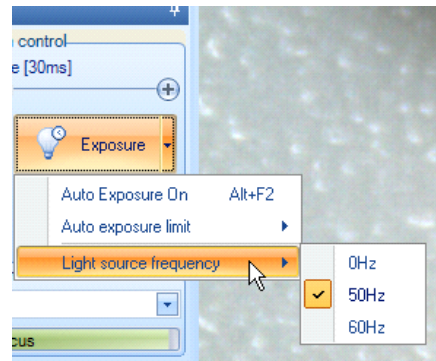

## 6.4 Auto Exposure

For automatic light adaption, turn on the Auto Exposure. Using this function will turn off the light source synchronization, which may result in flickering light or horizontal grey lines on the live video (see 4.3).



## 6.5 Colour

### 6.5.1 Colour Balance – Global

For white/grey balance adjustment on multicoloured preview, use **Colour balance – Global**.

To optimize the colour balance, remove any colour objects. An all-grey image makes the best balance.

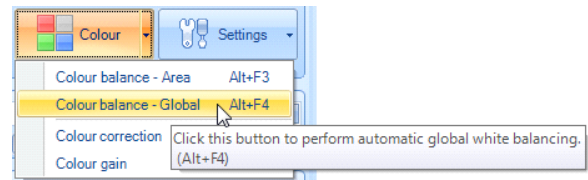

### 6.5.2 Colour Balance – Area

For preview with very limited areas of white/gray, use **Colour balance – Area**.



...and point with the cursor at the white/gray area, then click once:



## ..1 Colour Balance – Manual

For manual colour adjustments, use **Colour gain**:

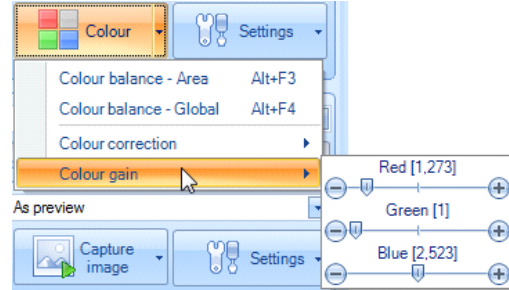

### 6.5.3 Colour correction

#### 6.5.3.1 For Infinity X, Infinity X32 and the DP cameras

Select the corresponding light source.  
If the light source is unknown, then experimentation with the functionality can be done.

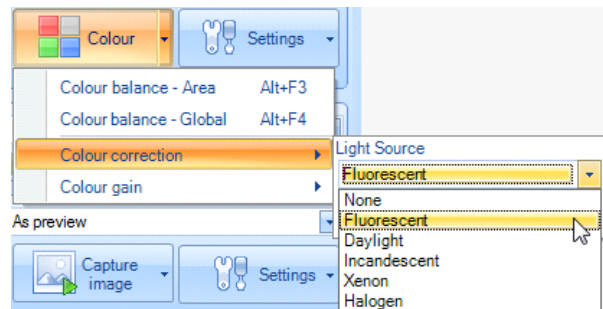

The colour temperature can be fine tuned using the slider.

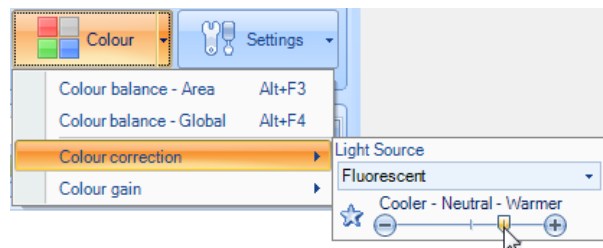



### 6.5.3.2 For Invenio and Invenioll Cameras

Select the corresponding light source.  
If the light source is unknown, then experimentation with the options can be done.

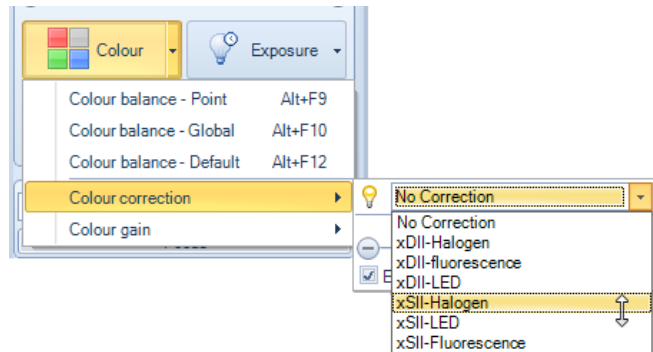

The colour temperature can be fine tuned using the slider.

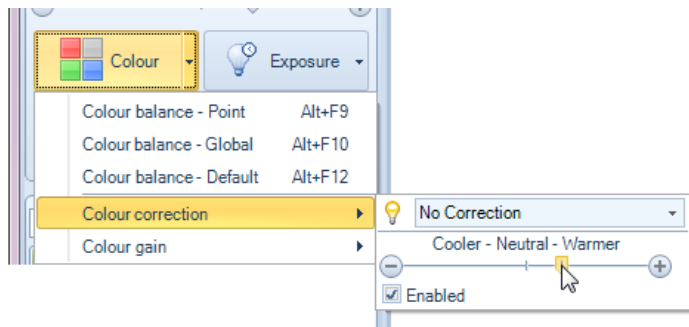

### 6.5.3.3 For Inveniolll Cameras

If the automatic white balance function fails to give perfect colors, the manual controls can be used for fine tuning.

The Inveniolll cameras comprises two methods of adjusting the colors:  
The preferred method is selected in the control panel-

#### **Temp/Tint adjustment**

Temp and Tint are independent, the temperature slider affects the color temperature, which is effectively the blue-yellow axis, while the tint affects the green-magenta axis.

Changing the value of one affects the appearance of the other, hence it makes a difference whether you change the tint value first and then move on to the temperature, or the other way around.

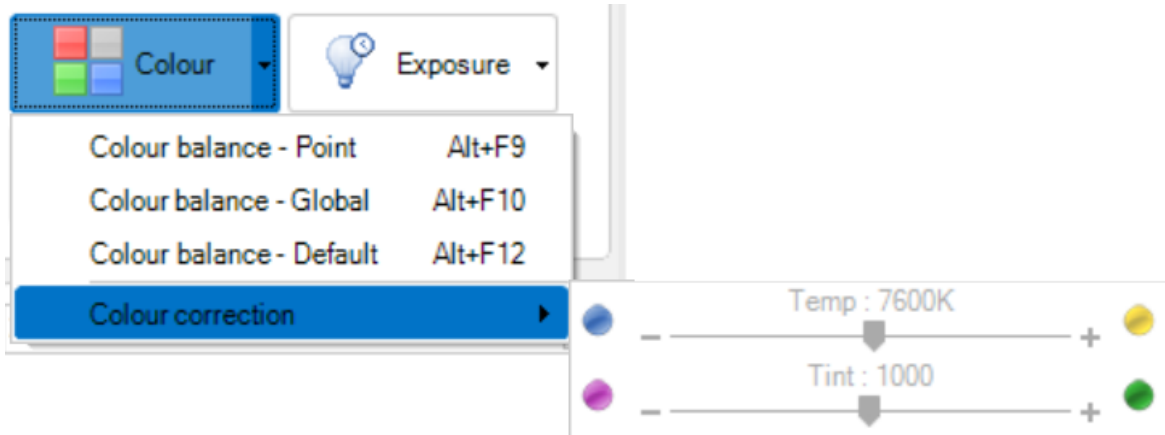

Color balance corrections will be done primarily with the Color Temp slider, with minor adjustments to the Tint slider.

### **RGB adjustment**

In this mode the colors are adjusted individually.

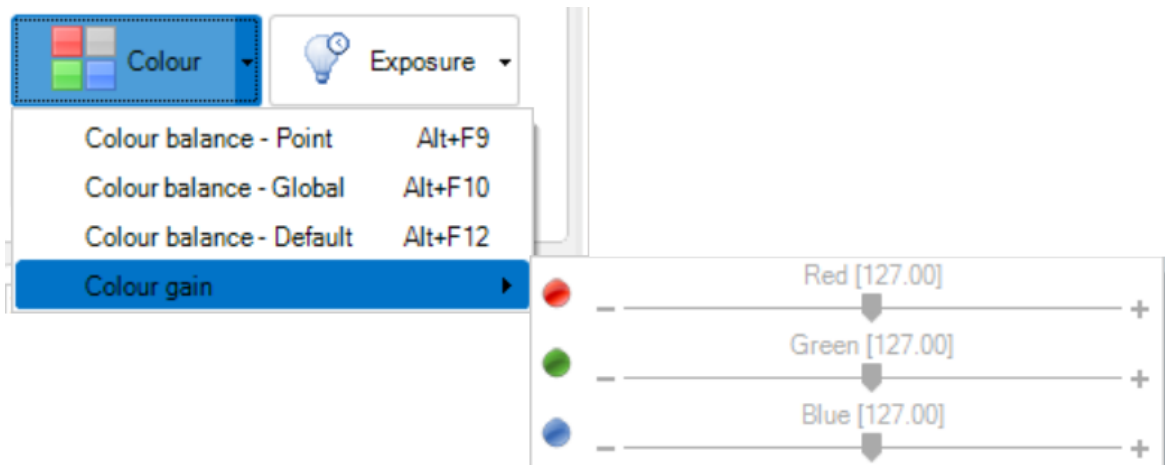

## 6.6 Preview Histogram

The preview histogram is a tool to ease the camera parameter setting.

The histogram shows the distribution of red, green and blue in the preview image.

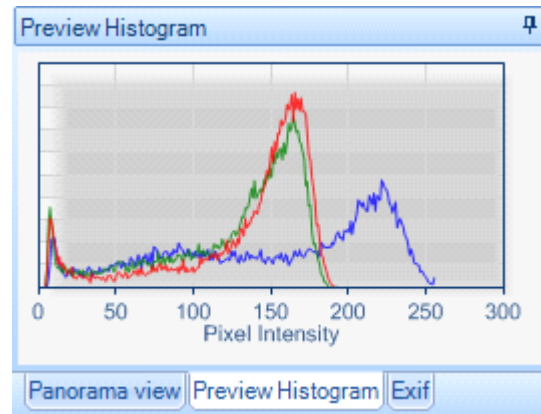

## 6.7 Using Properties from an Image Stored in a Gallery

When an image is stored in a gallery, a file containing all the camera properties used when the image was captured is also stored. This is a unique feature, and makes it easy to revert to the settings used when the image was captured.

To copy the camera settings from an image to a camera, right click the image and click **Copy image settings to camera**. Note:

This feature works only from within the gallery.

The settings are stored in a separate file.

The feature only works with the same camera type that was used for capturing the image

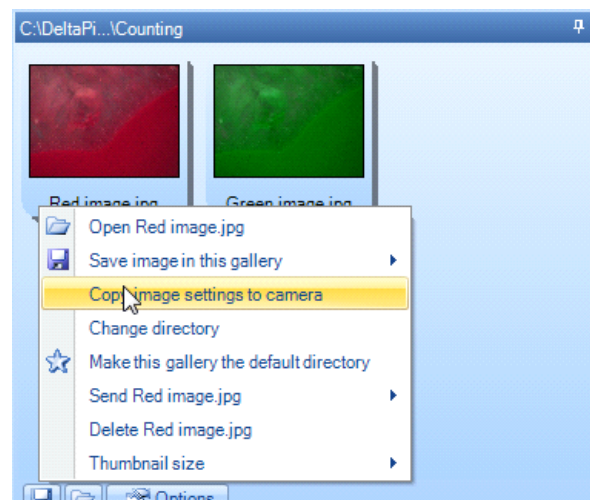

## 7 Still Image Capture

## 7.1 Capture Still Image

Select the desired format and image type. In most cases the capture format can be selected different from the preview format.

Note that the capture options vary depending on the camera type.

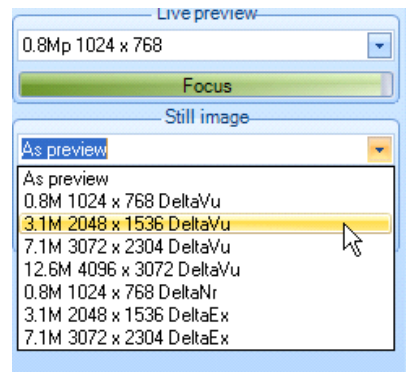

Then click on **Capture image** to capture an image.

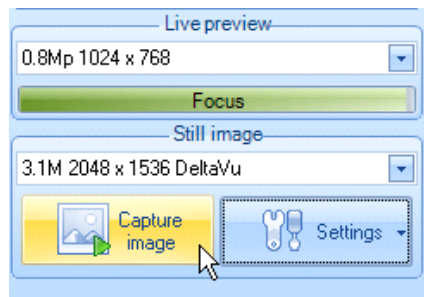

### 7.1.1 Insert Scale Bar

A calibration bar can be automatically inserted on captured images. Note that this requires calibration.

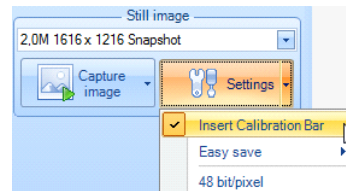

### 7.1.2 Crop Image

Crop to Preview Region

It is possible to capture only a part of an image.

In the Capture settings, check the 'Crop to

## Preview Region'

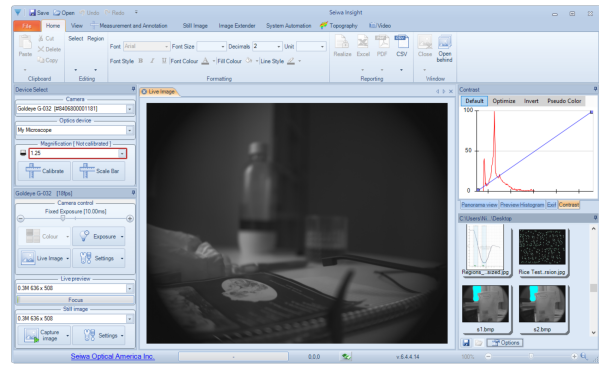

Zoom in on the part of the image you would like to acquire – then capture the image.

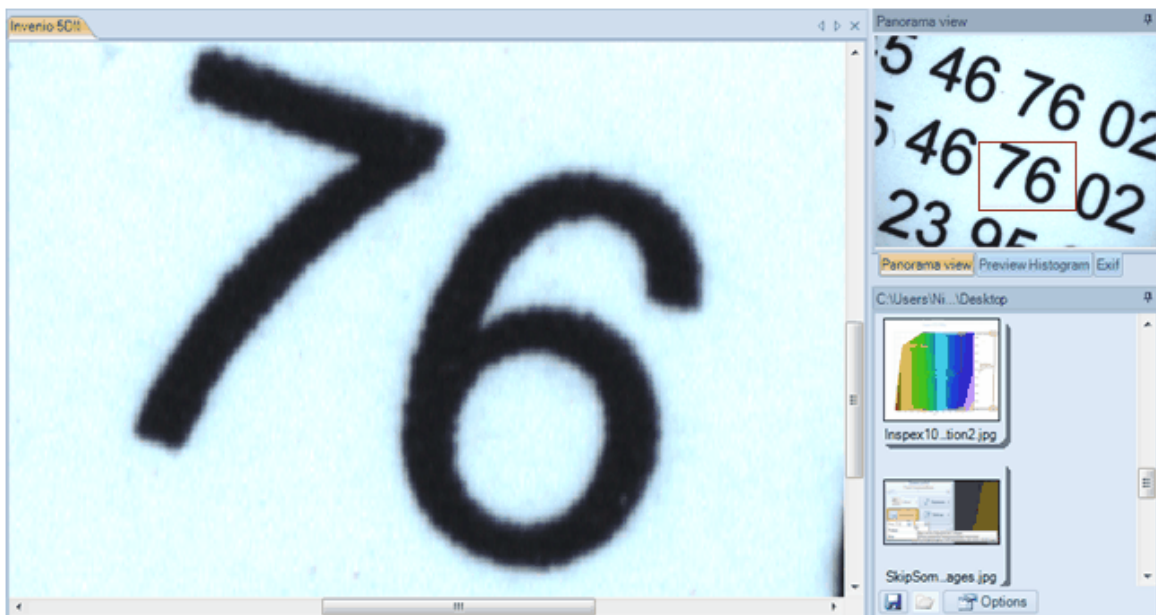

## Crop to Square

This option will crop captured images to be square 1:1 format.  
The live preview image will not be affected.

### 7.1.3 Easy save

The work flow can in some cases be optimized by using the **Easy save**.

This automates the process of naming and saving images – images are simply named, saved and optionally closed automatically.

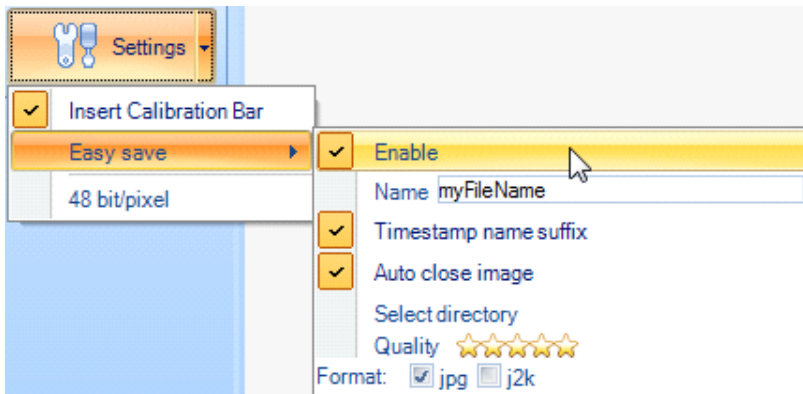

Changing the easy save file name also effects the general image naming, even when easy save is disabled.

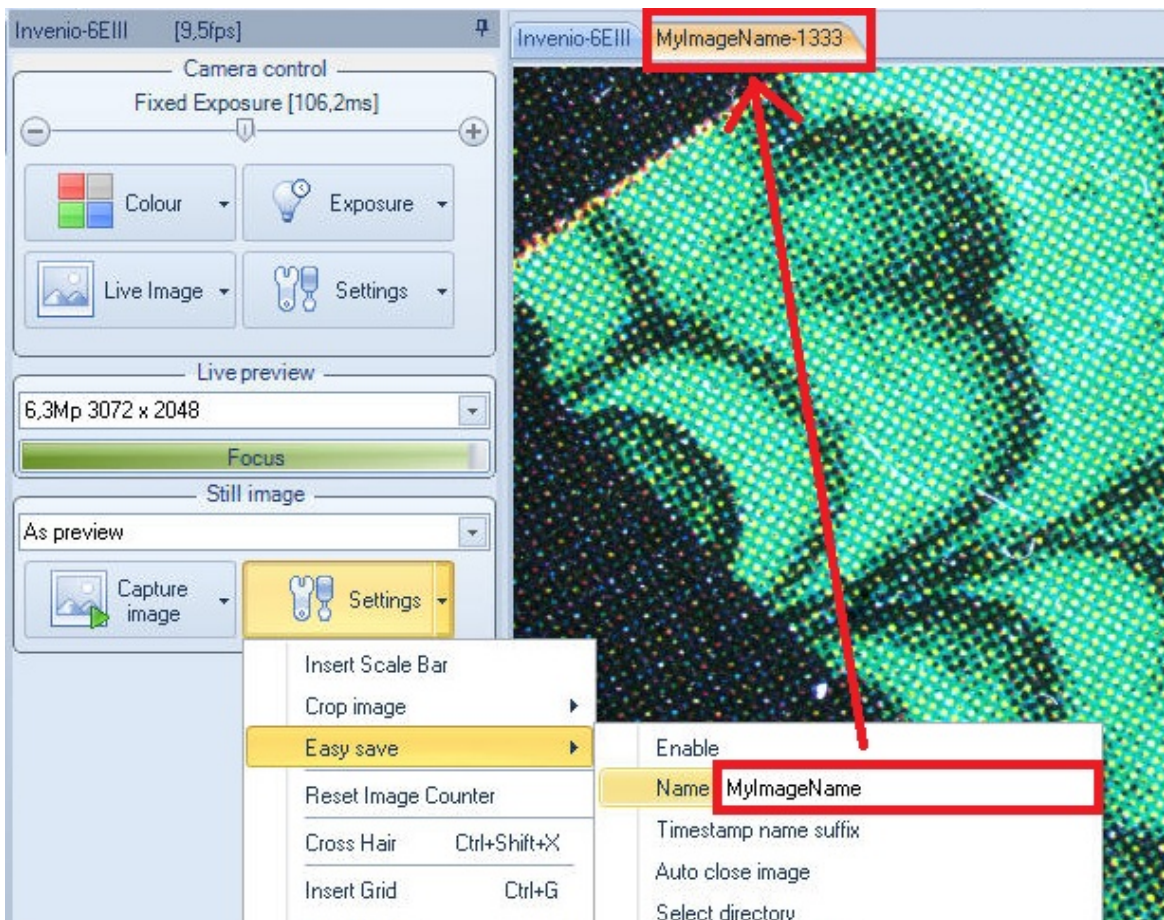

### 7.1.4 Reset Image Counter

The sequential numbering of images can be reset, or set to a specific value

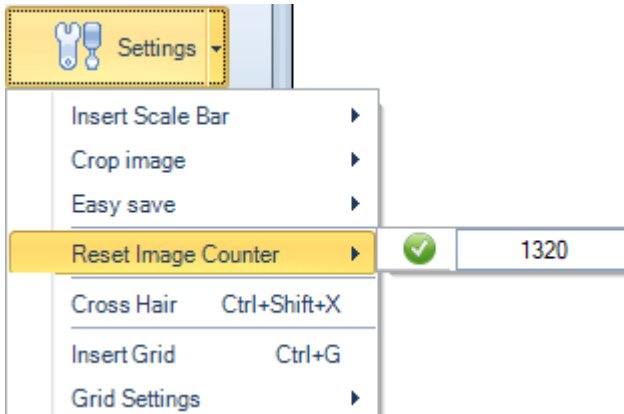

Example: 1320 will be used as the next image counter index.

### 7.1.5 48 Bits per Pixel Mode

Some CCD camera models support 10, 12 or 14 bits per raw pixel. The common colour format for these cameras is RGB48.

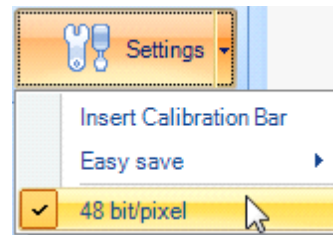

Please note that RGB48 images can only be saved in the TIF file format. The files are uncompressed, and very space consuming.

### 7.1.6 Insert Crosshair overlay

To insert a cross hair on top of the live image (or on a captured still image), click the 'Cross Hair'.

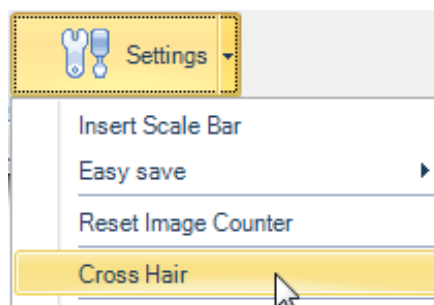



### 7.1.7 Insert Calibrated Grid overlay

To insert a calibrated grid on top of the live image (or on a captured still image), click the 'Insert Calibrated Grid' (Shortcut Ctrl-G)

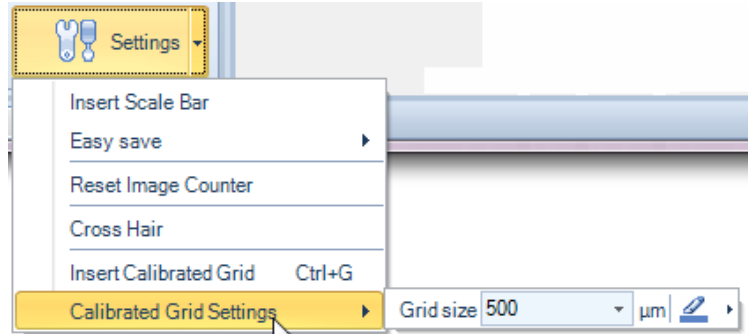

The grid properties, grid size and line color can be set in the 'Calibrated Grid Settings'.

## 7.2 Capture Image Using the Snapshot Mode

DeltaPix CCD cameras offer snapshot capability. This means that exposure and gain snapshot settings different from the preview settings can be used.

This is very useful e.g. for acquiring fluorescence images with long exposure. It is possible to have a relative quick - but lower quality - preview frame rate by setting the gain high and enabling binning.

Activate the snapshot window from the menu **Settings**.



It is recommended to use the **Use Snapshot Gain** option.

If the acquired images suffer from pixel hotspots, these can be gracefully handled by the **Auto Fix Hotspots** option.

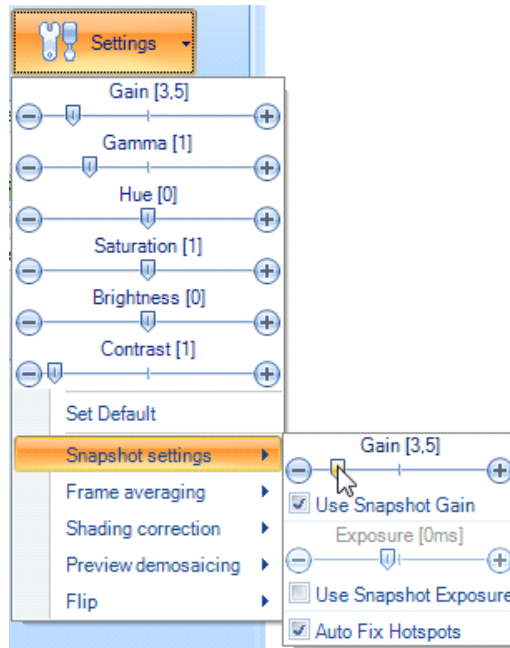

The snapshot function makes it easy to acquire an image as in the preview, but in maximum quality, low gain (for low noise), and no binning (for high resolution).

The recommended way to use DeltaPix CCD or EXMOR cameras for fluorescence applications is listed below:

Increase the live preview gain to a high value.

If the image is not bright enough yet, select binning x2.

In the snapshot settings menu, set the gain to 2.5 – 3.5

This makes it possible to both have a live image with high frame rate, and to capture snapshots with long exposure time (up to several seconds) and low noise at the same time.



Note: Snapshot mode is only available for CCD and EXMOR cameras. This is the default acquisition mode.

## 7.3 Save Image

### 7.3.1 Image Saving in a Gallery

To save the image, click on the **disk button** and **Save in**.



### 7.3.2 Image Saving by Right-clicking the Image

To save the image, click the **Save as**:

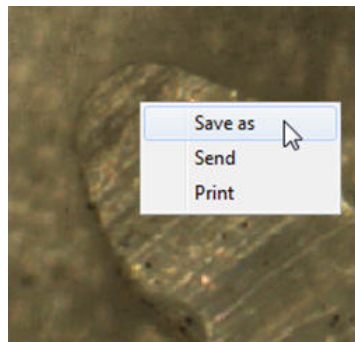

### 7.3.3 Image Saving using the Standard Menu

To save the image, click on the **Save As** button

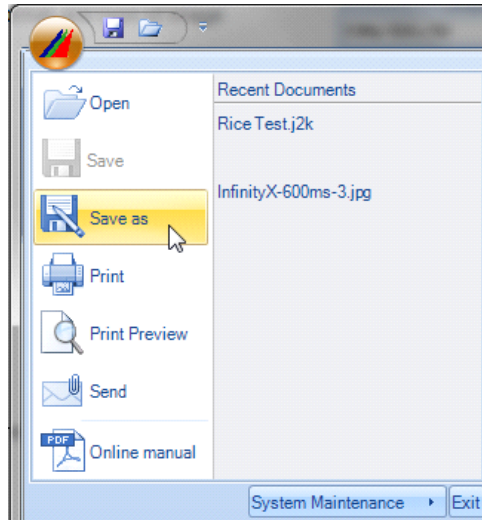

### 7.3.4 Image Saving by Right-clicking a Gallery

To save the image, right-click in the destination gallery. Quality and file type can be specified.

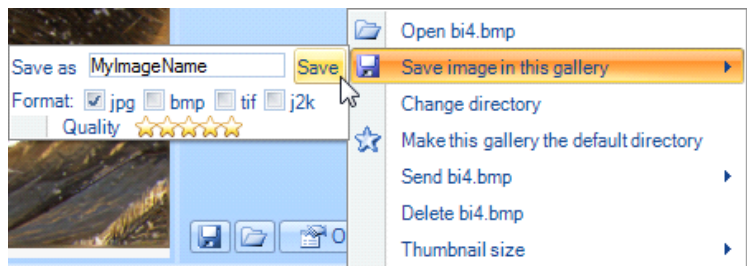

### 7.3.5 EXIF

Exif is a specification for the image file format used by digital cameras. The specification uses the existing JPEG formats, with the addition of specific metadata tags. Only JPEG files are supported.

The title, subject, comments, author, and copyright tags can be defined. Leaving a field empty means that the tag is not used. To embed the tags with JPEG files, check the 'Embed into JPEG files' checkbox.

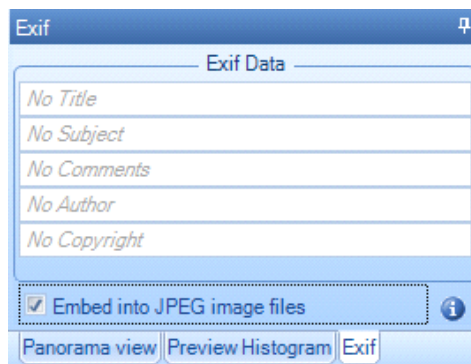

Example of using the tags.

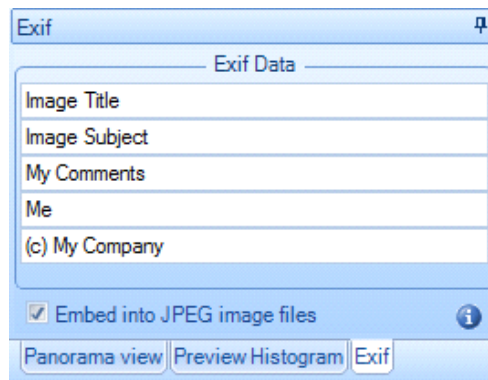

The saved files are shown in Windows file explorer. Note that also Camera Model, Camera Maker and Exposure time can be shown. You may need to configure the file explorer to see all the tags.

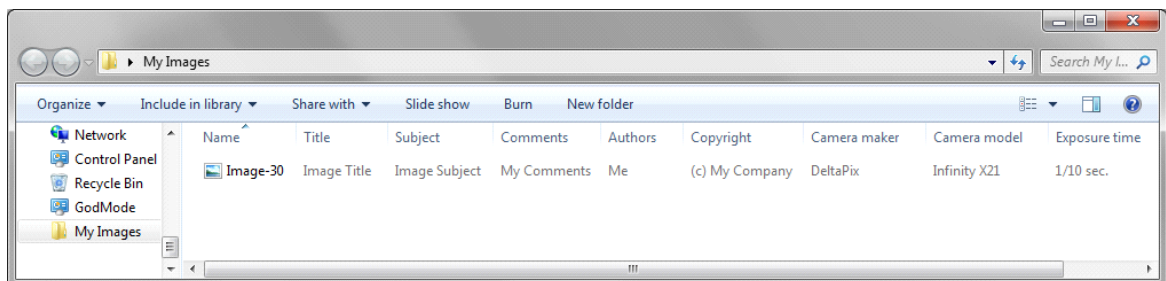

## 8 Calibration

It is important to calibrate your cameras and optics before using them for measurements. Using the program without correct calibrations will result in incorrect measurements.

The optics editor is an advanced tool to configure the optics of a microscope.

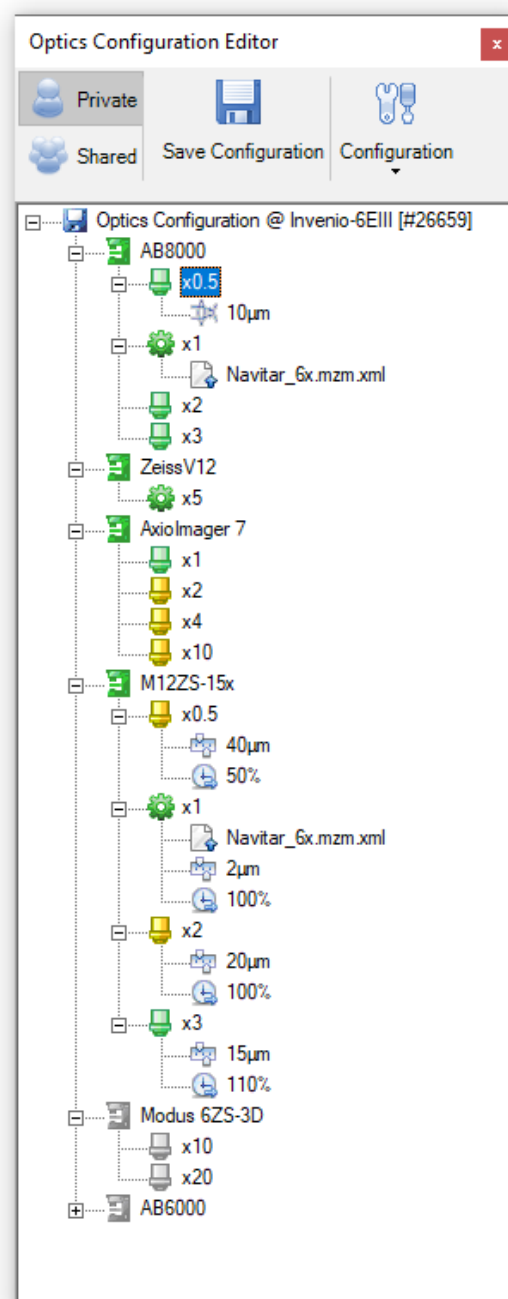

### The optics editor

The optics components of a microscope can be configured by parameters like depth-of-field, field-curvature and preferred exposure time.

Colors are used to indicate the status of a component.

- Green will indicate that everything looks good - for an objective this indicates that the a calibration is done.
- Yellow indicates medium-good. - for an objective this indicates that a calibration was not done, but interpolation from another calibration is used.
- Red indicated not-good - for an objective this indicates that no calibration is done.

Grey indicates unknown or unused state. In the above screen shot the grey "Modus 6ZS-3D" and

"AB6000" are associated with another camera than the currently used Invenio 6EIII (#26659). Switching to the camera used for these microscopes will show another view:

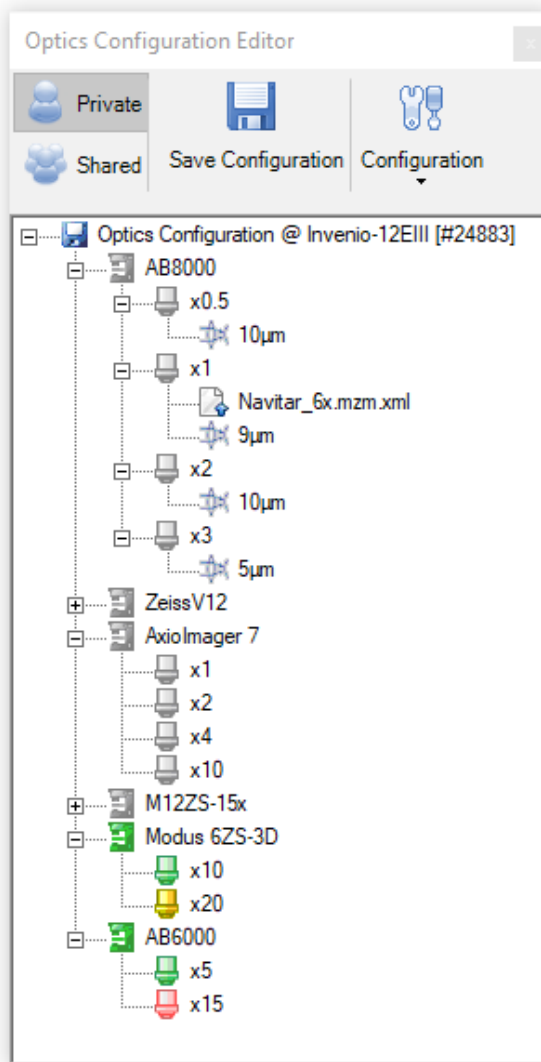

## 8.1 Defining the optical device and magnifications

Select and connect your camera and your objective lens to calibrate. The recommended calibration procedure is described in the following:

From **System Maintenance** in the DeltaPix logo menu, select **Edit Optics Configuration**:

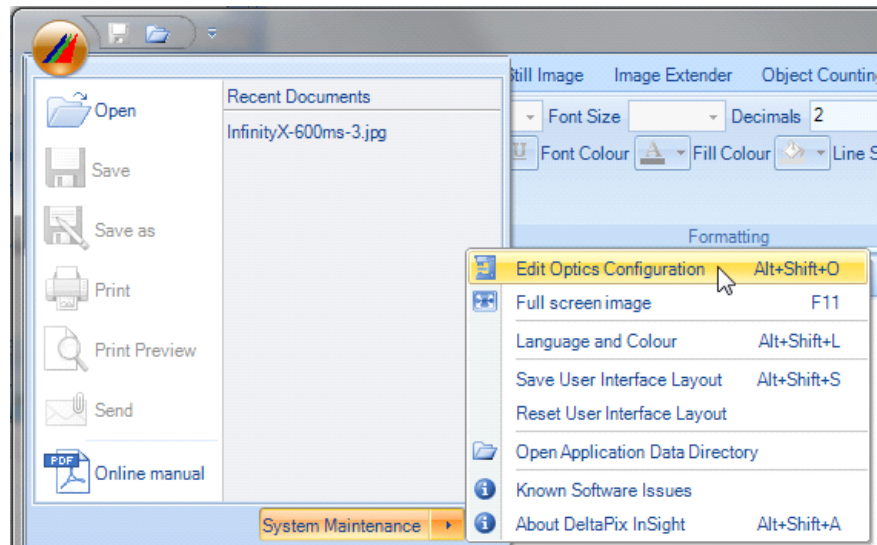

### 8.1.1 Make the calibration private or shared

One of the first things to consider is whether the calibration is private to each user, or shared by more users. A user is defined by the Windows login.

If the 'Shared' is selected, then other users doesn't need to go through the calibration process, but can use existing shared calibrations.

Select Private or Shared, by clicking one of the buttons



Optionally a configuration can be copied from private to shared, or from shared to private. Please note that these copy operations are non-reversible – take care.

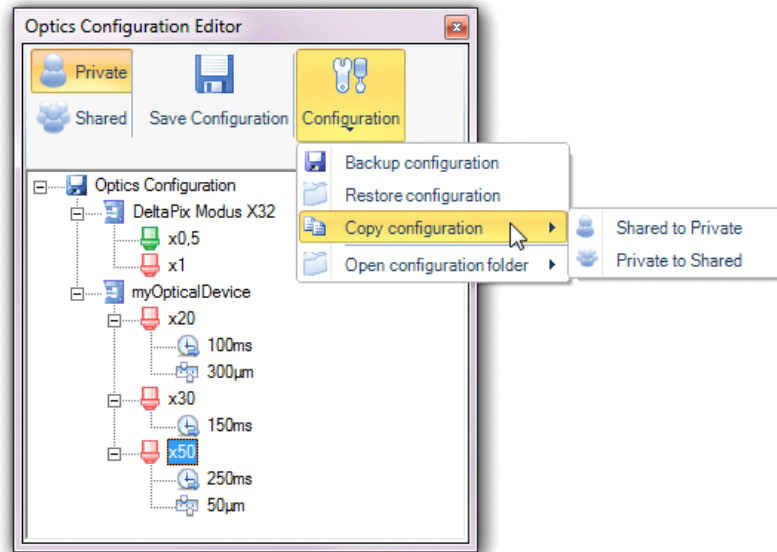

### 8.1.2 Add an optical device

Right-click on **Optics Configuration** to name this system, type the name of the system, then select **Add**:

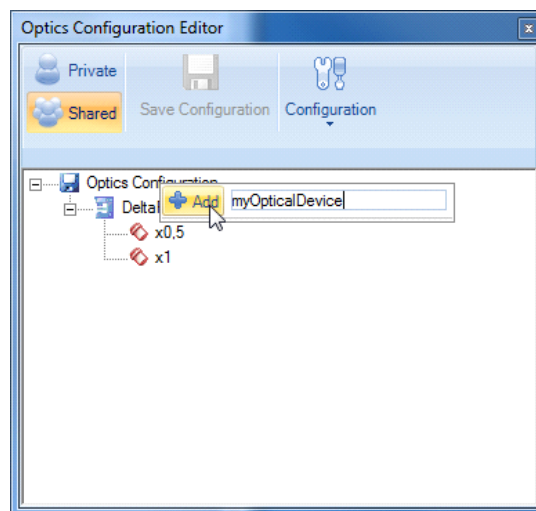



### 8.1.3 Add an optical magnification

Right-click on the new **system name** to **set magnification** of the objective lens in use, then select **Add**, and type the numerical magnification.

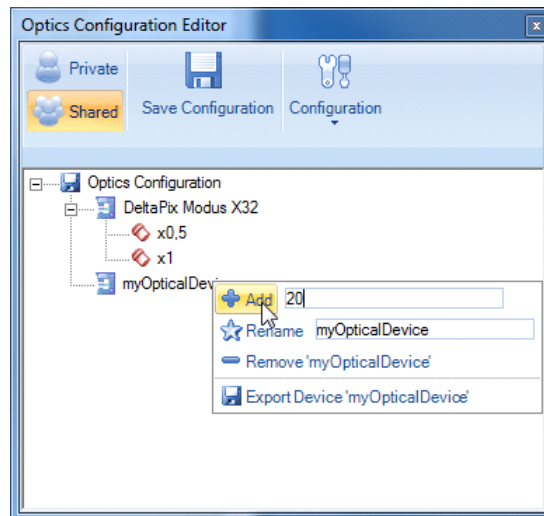

### 8.1.4 Add a preferred exposure time for an objective

For each objective the preferred exposure time can be defined. This definition is useful in cases where the auto exposure leads to undesired image intensity.

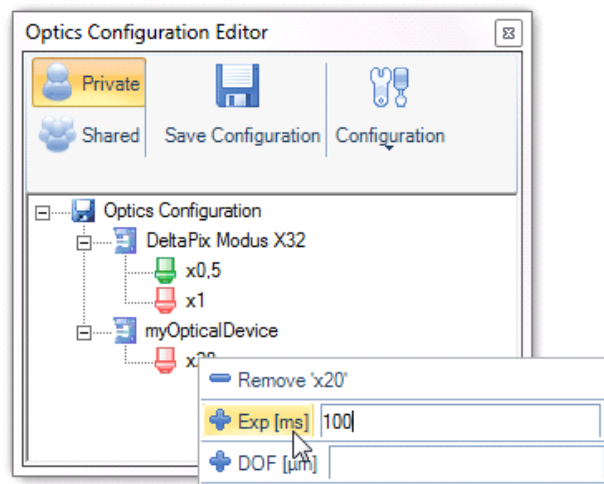

#### 8.1.4.1 Relative exposure

The relative exposure mode can be defined in two ways:

##### 1. Using only the "%" character

Instead of entering a fixed exposure time you can enter a '%' digit. This will make the exposure for this objective relative to the magnification.

As an example, if the exposure time for a 10x magnification is set to 25ms. If you then change to a 20x objective with the exposure set to '%' then the exposure time will be 50ms.

*In this mode the exposure time is simply inverse proportional to the magnification.*

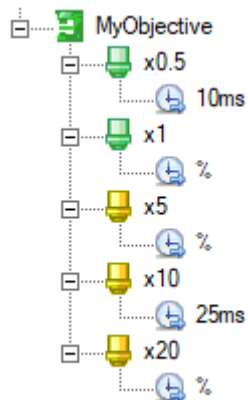

**Example of setting both fixed and relative exposure time.**

## 2. Using the "%" character and a value.

Often the optimal exposure time is not perfectly inverse proportional to the magnification. By entering a value along with the "%" character a more coarse exposure time can be set.

As an example, if the exposure time for a 10x magnification with the exposure set to '18%' is set to 25ms.

If you then change to a 20x objective with the exposure set to '40%' then the exposure time will be  $(40 / 18) * 25\text{ms} = 55.5\text{ms}$

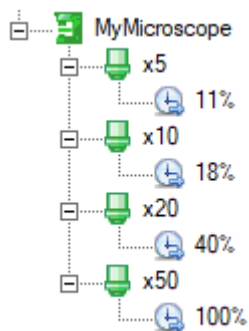

**Example of using fixed relative exposure.**

### 8.1.5 Add a DOF for an objective

For each objective the Depth of Field can be defined. This definition can be automatically used in 'Extended Focus' and 'Auto Focus'.

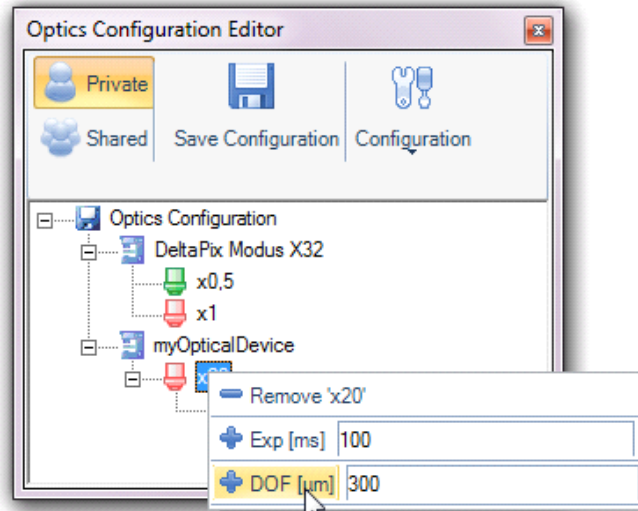

### 8.1.6 Adding an information file

Some motorized zoom objectives are partially calibrated by DeltaPix prior delivery. The calibration and zoom motor information is delivered as an `objectiveName.mzm.xml` file. This file must be associated with the objective in the optics editor.

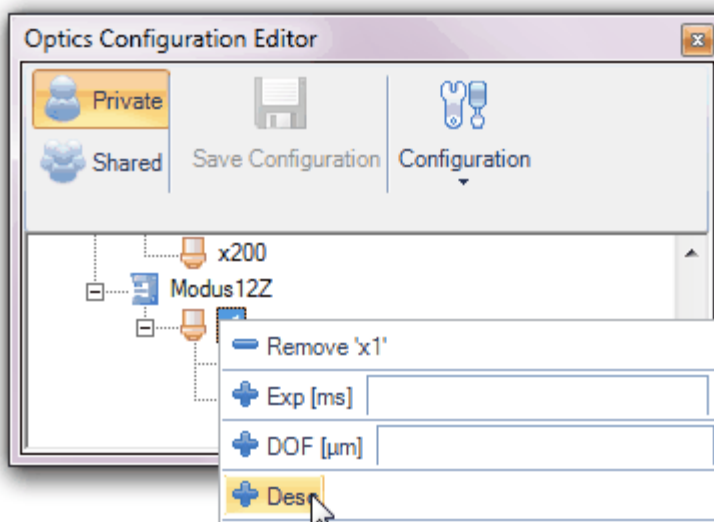

In the open file dialog, select the (as example) `Navitar_6x.mzm.xml`. This associates the motor-zoom-model file to the objective calibration.

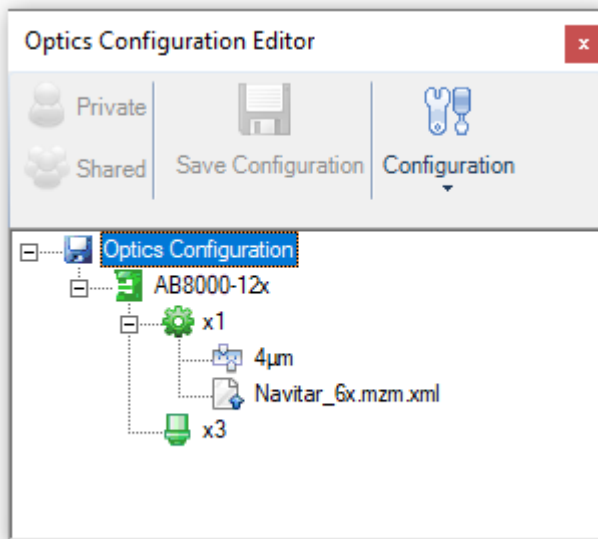

Example optics configuration - the x1 is a motorized zoom objective with an associated description file. The file holds information on:

- Zoom range and zoom profile.
- Motor run and hold current.
- Limit switch polarity.
- Predefined click stops.
- Motor speed [steps/sec]

### 8.1.7 Defining camera- integrated focus controller Z-calibration

Cameras with integrated motor back-focus can be selected as focus controllers – in the same way as other focus controllers.

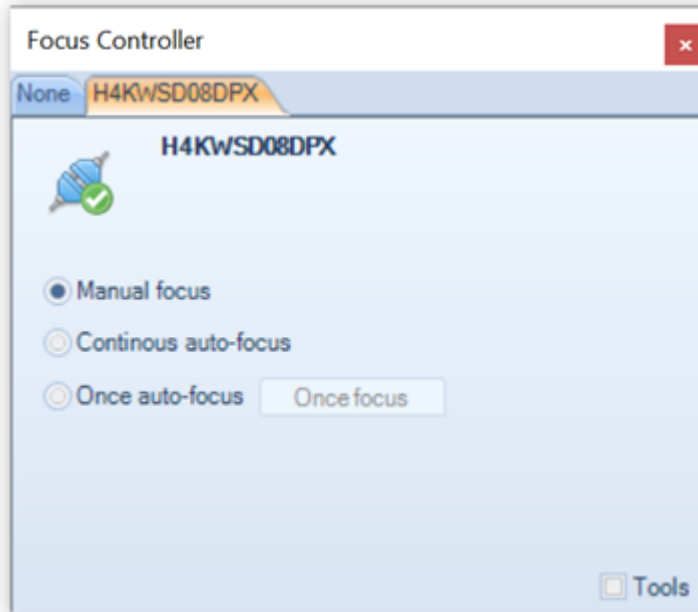

The integrated focus controller is simple to configure, just needs to be selected,

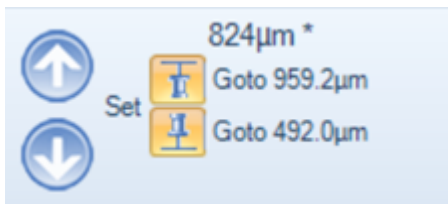

When selected, the focus control will show the actual position, and the arrow buttons will move the focus. The "\*" means that the focus is uncalibrated – and that the readout value is the raw back-focus distance.

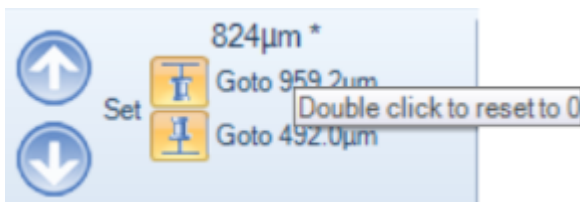

The focus value label can be mouse clicked to obtain special functionality:

- Double click to set position to zero/reference position.
- Ctrl-click to go to the neutral back focus position. This is the position that is recommended for XY calibration. Note that depending on the focus calibration, this may

take a value different from 0.

#### 8.1.7.1 Calibrating the focus controller and definition in the optics definition editor

To make a focus calibration, it is recommended to use the DeltaPix focus calibration unit. It consists of calibration slider mounted precisely on a ramp.



**DeltaPix focus calibration unit.**

Depending on your optical magnification, select an appropriate scale on the slider - the scale bar should cover as much of the field-of-view as possible.

First focus on one end of a slider. In the optics configuration editor, click "Focus Position 1".

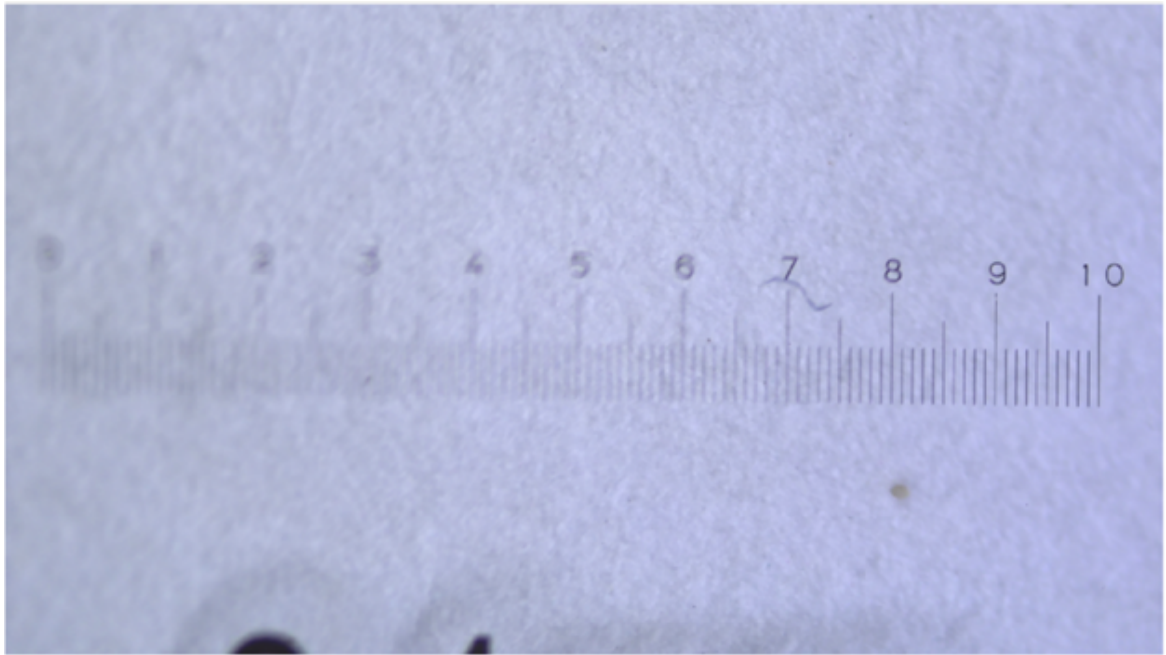

In the optics configuration editor, click "Focus Position 1".

A screenshot of the optics configuration editor interface. It features several settings with expandable/collapsible icons (green plus and red minus) and buttons for focus positions. The settings include:

- Exp [ms] (input field)
- DOF [um] (input field)
- Motorized Zoom Description File
- Focus Calibration section containing:
  - Focus Position 1 (button with down arrow)
  - Focus Position 2 (button with up arrow)
  - Focus Distance 100 [um] (input field)
- Focus Plane Compensation 10 [um] (input field)
- Remove 'x10' (button with red minus)

Below this main panel, there is a secondary panel with:

- Focus Position 1 (button with down arrow)
- Focus Position 2 (button with up arrow) and an input field containing 374 [step]

Note: After reading the position, the back focus stepper motor position is displayed when hovering the button. So, position 1 is 374 steps in this example.

Then, if possible, focus on the other end of the slider. In the optics configuration editor.

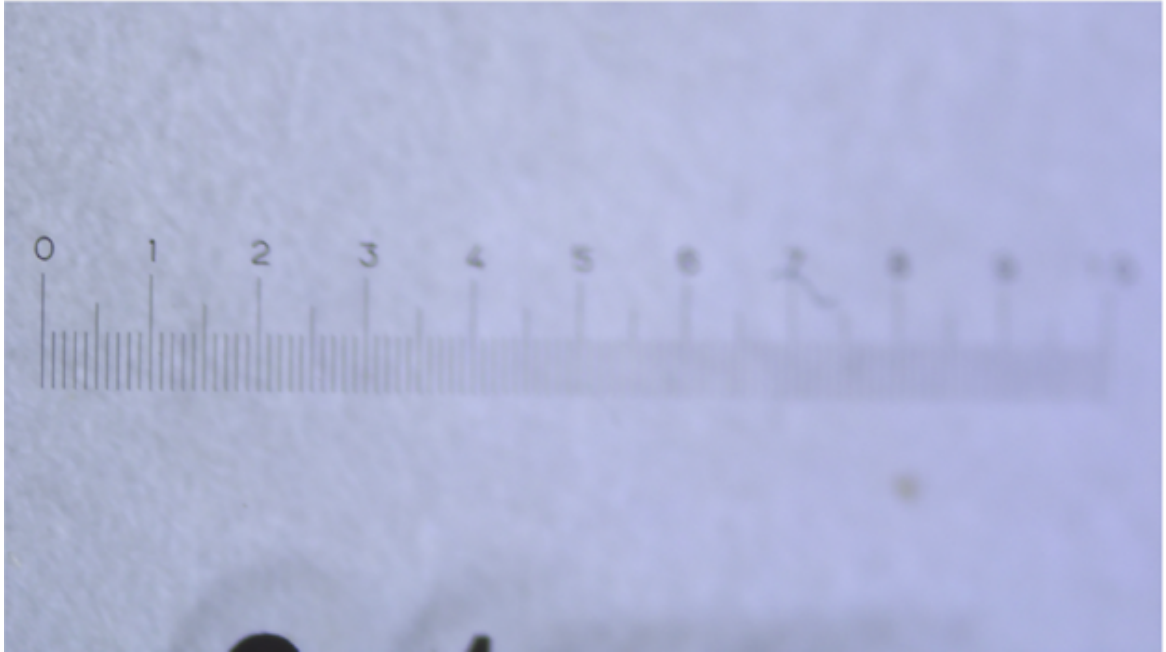

Click "Focus Position 2".



A screenshot of a software calibration interface. It features several settings, each with a green plus icon in a circle. The settings are: 'Exp [ms]' with an empty text box; 'DOF [um]' with an empty text box; 'Motorized Zoom Description File' with a dropdown menu showing 'Focus Position 1'; 'Focus Calibration' with a dropdown menu showing 'Focus Position 2' (highlighted), and a 'Focus Distance' input field with the value '100' and a '[um]' unit label; 'Focus Plane Compensation' with an input field containing '10' and a '[um]' unit label; and 'Remove 'x10'' with a red minus icon in a circle.

A close-up of the 'Focus Position 2' dropdown menu. It shows two options: 'Focus Position 1' and 'Focus Position 2' (highlighted). Below the dropdown is a 'Focus Distance' input field with the value '509 [step]' and a '[um]' unit label.

Note: After reading the position, the back focus stepper motor position is displayed when hovering the button. So, position 2 is 509 steps in this example.

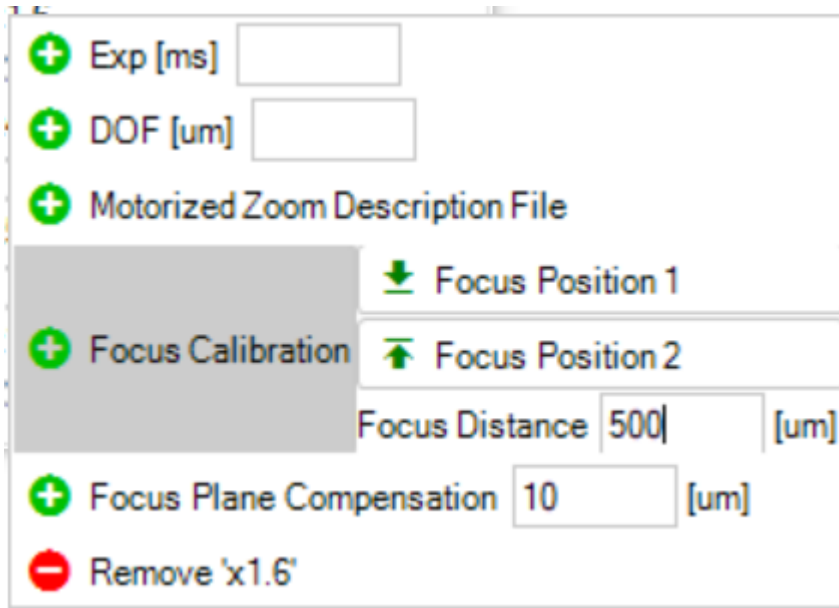

The screenshot shows a software interface with several settings:

- Exp [ms]
- DOF [um]
- Motorized Zoom Description File
- Focus Calibration (highlighted) with a sub-menu:
  - Focus Position 1
  - Focus Position 2
  - Focus Distance  [um]
- Focus Plane Compensation  [um]
- Remove 'x1.6'

Finally enter the real focus distance between Position 1 and Position 2.

Due to the geometry (30-60-90 angles) of the calibration device the actual height is  $\frac{1}{2}$  of the calibration slider read.

So, in this example it is 500um.

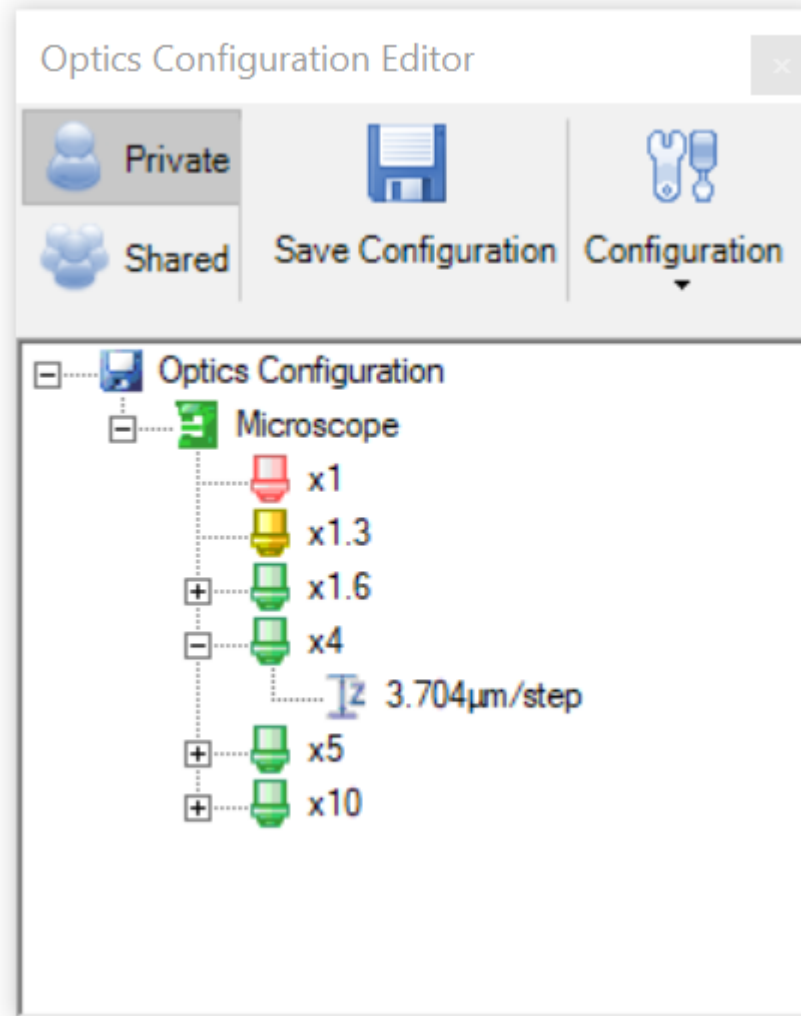

The focus information will show with the objective. The readout shows the focus change per back-focus step. In this example  $500/(509 - 374) [\mu\text{m}/\text{step}] = 3.704 [\mu\text{m}/\text{step}]$

### 8.1.8 Defining field curvature compensation

Field Curvature, also known as “curvature of field” or “Petzval field curvature”, is a common optical problem that causes a flat object to appear sharp only in a certain part(s) of the frame, instead of being uniformly sharp across the frame.

This happens due to the curved nature of optical elements, which project the image in a curved manner, rather than flat.

And since all digital camera sensors are flat, they cannot capture the entire image in perfect focus.

This especially becomes an issue when capturing topographic images, which may tend to have an unwanted curvature.

The compensation – which is approximated by a parabola – is the difference in focus from center of image towards image corners.

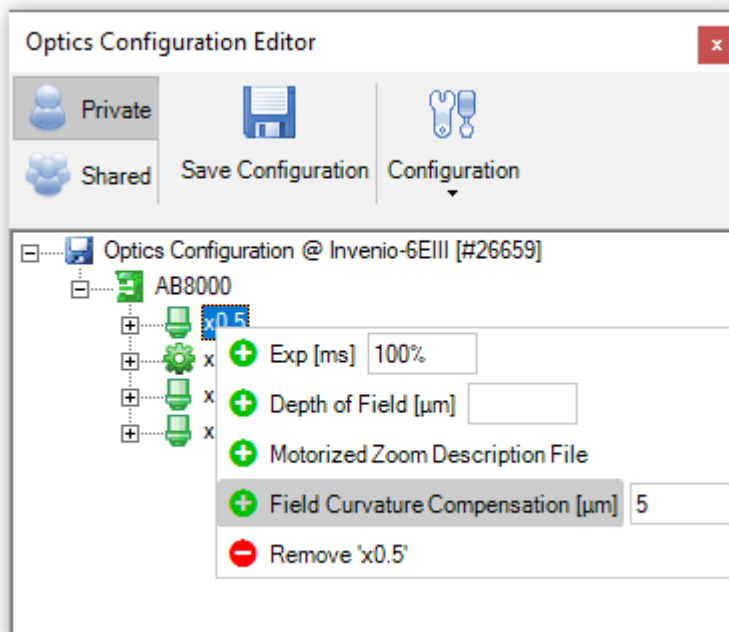

Example of adding a compensation value of 10μm to the 0.5x objective.

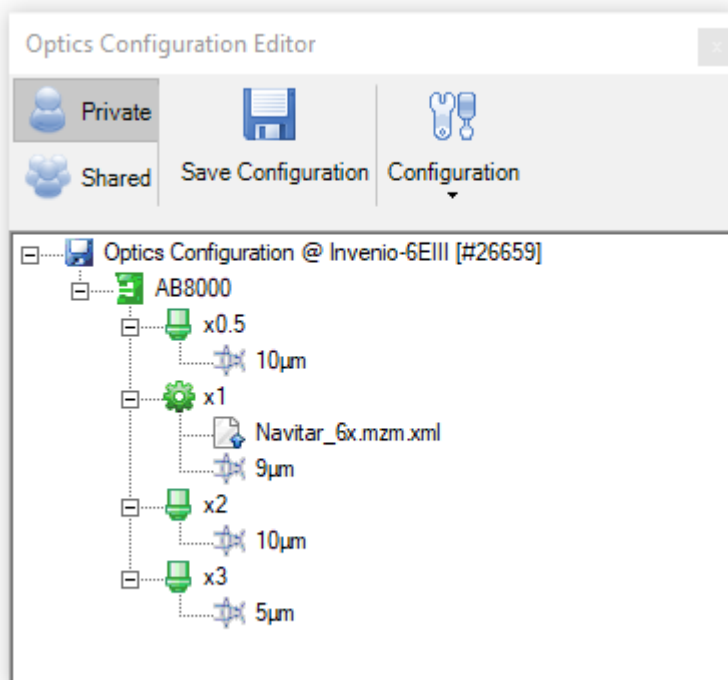

Example of a motorized Navitar 6x motorized objective with virtual-fixed objectives at the objectives click-stops.

Using the click-stop position will activate the designated compensation values.

The field curvature compensation will automatically appear in the 3D topography. If a compensation value is not available, then a slider will appear, for manual compensation.

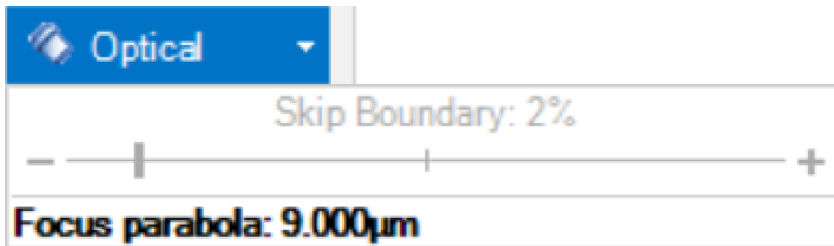

References:

- <https://photographylife.com/what-is-field-curvature>
- <https://www.coursera.org/lecture/design-high-performance-optical-systems/what-is-petzval-radius-Yy2ya>

## 8.2 Calibrate One Objective

Select and connect your camera and your objective lens to calibrate. The recommended calibration procedure is described in the following:

### 8.2.1 Calibration slider

Place a **calibration slide** in your system, so the markings on the ruler are shown on screen:

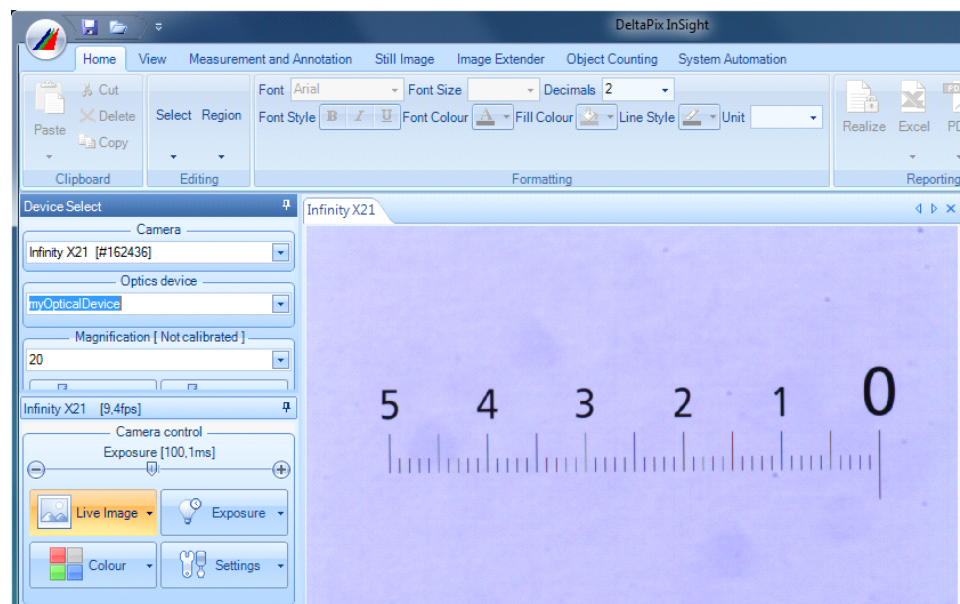

## 8.2.2 Select the device and magnification to be calibrated

In this example we are going to calibrate the 'MyOpticalDevice' with the x20 objective.

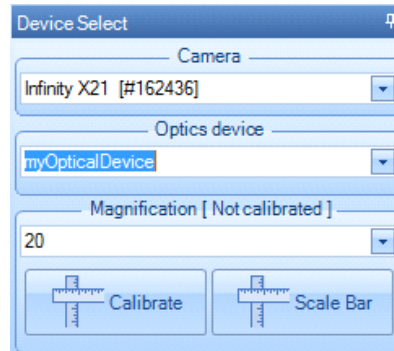

## 8.2.3 Draw calibration ruler

Click on **Calibrate**, and **Draw Calibration Ruler**. Then, on the image, draw a ruler, covering the calibration marks.

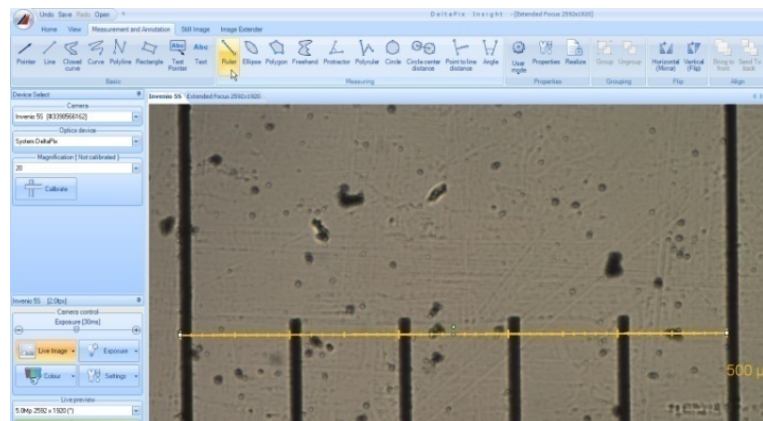

Note that calibration can be done both on the live preview and on a still image.

## 8.2.4 Calibrate to real world metrics

Click on **Calibrate**, then insert the **true length** of the calibration line and choose the **right unit**

Then select **Calibrate this optics objective lens** to finish this calibration process:

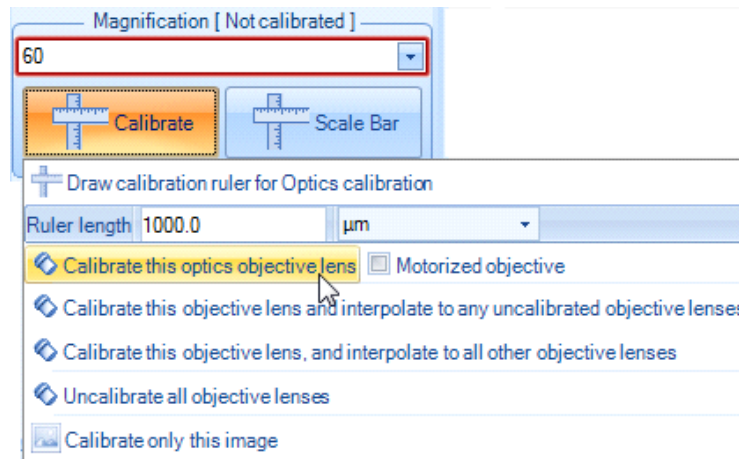

The 'Motorized objective' should only be checked when calibrating a motorized zoom objective.

## 8.3 Calibrate a Camera and More Objectives

If you have multiple objective lenses connected on the microscope, then it is possible to use InSight to interpolate or extrapolate the rest and only manually calibrate one objective lens.

Please note, that the software only uses one set of true values to calculate the rest by interpolating. This may cause imprecise measurements if the magnification of the objective lenses are not very close to the nominal magnifications.



For precise measurements we recommend calibrating every device individually. The best result is achieved if calibration is done using a still image captured at maximum resolution.

## 8.4 Calibrating a motorized zoom objective

### 8.4.1 Defining the Objective in the Optics Editor

Initially the motorized zoom objective must be defined in the Optics Editor. **The objective should always be defined as a x1 objective.**

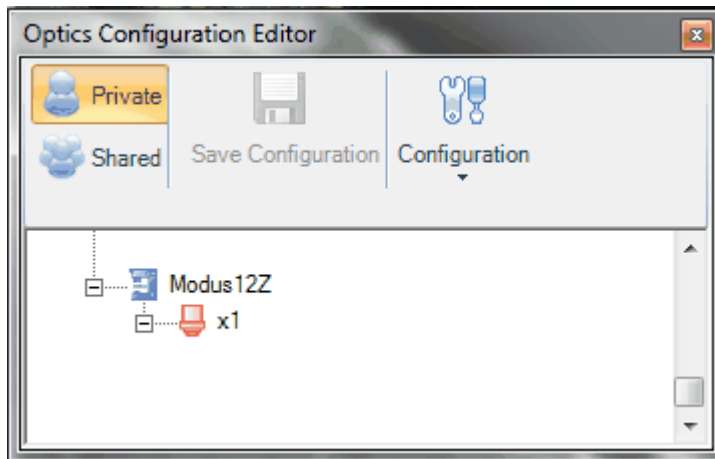

### 8.4.2 Associating the Description file

The motorized objective comes along with a factory calibration file describing its characteristics.

The file is needed to ensure precise calibration.

This file is an XML file holding the Motor Zoom Model (mzm). This file must be loaded into the optics editor.

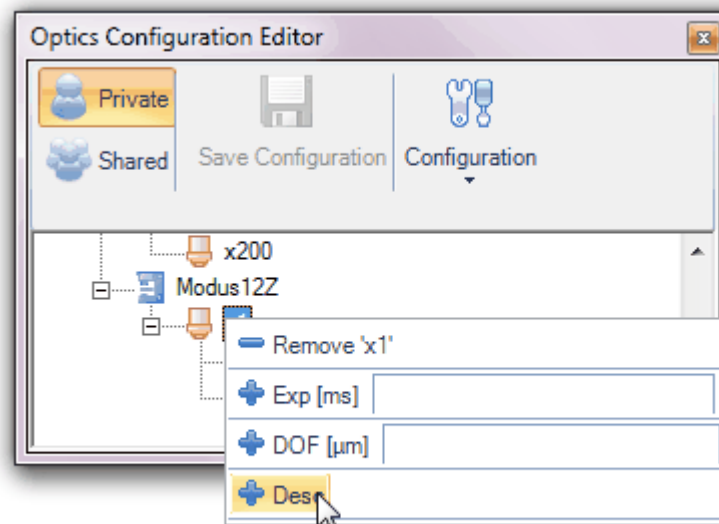

In the open file dialog, select the (as example) NEW MS-12HZ-L125-P2.mzm.xml

This associates the motor-zoom-model file to the objective calibration.



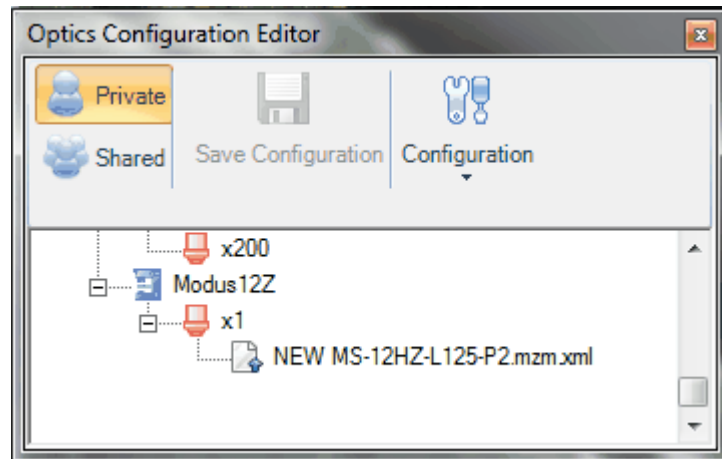

!

### 8.4.3 Defining the Depth of Field

The default Depth of Field for the motorized objective is defined in the description file - and normally this is good. Optionally the default Depth of Field can be overridden by defining a new value in the Optics Editor. The entered Depth of Field must be the value at HIGHEST magnification.

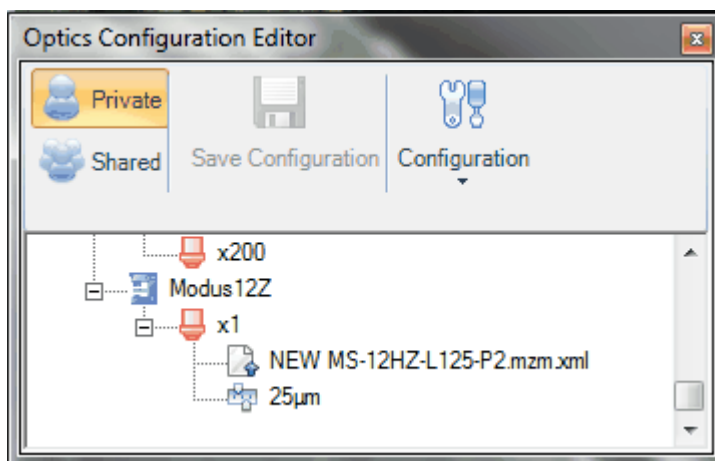

Example of an overridden Depth of Field - in this case 25µm.

### 8.4.4 Calibrating the Objective

Calbrate the objective in its **HIGHEST** zoom position.

To calibrate, draw a calibration ruler.

The 'Motorized Objective' checkbox must be checked.

Enter the correct 'Ruler Length'.

Click the 'Calibrate this optics objective'.

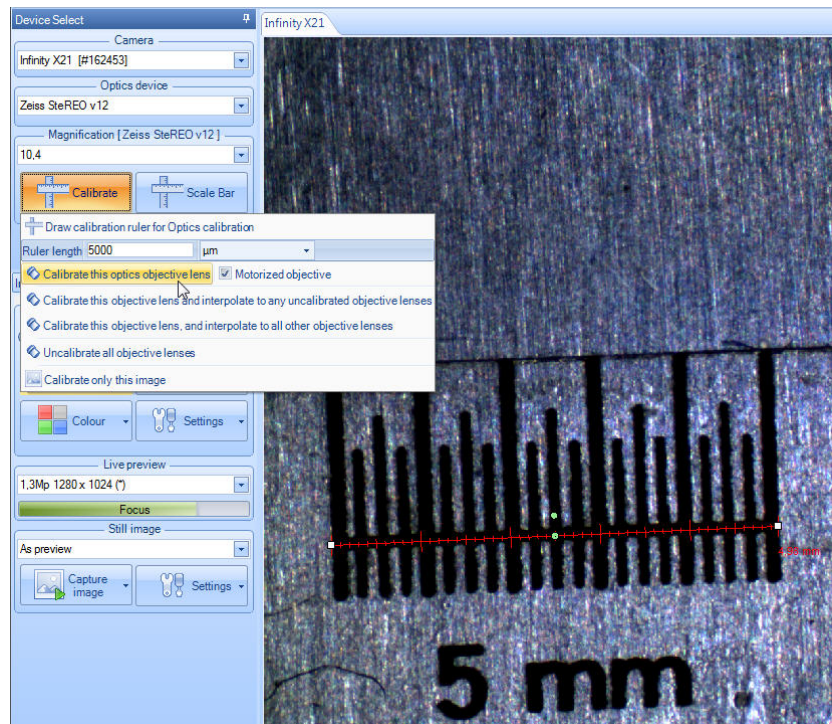

NOTE: Work careful and precise – all precision matters!

## 8.4.5 Motor Zoom - Virtual fixed objective positions

The precision of a motorized zoom calibration can be increased at selected positions, these positions can be calibrated as virtual fixed objectives.

### The Optics Editor

In the optics editor simply add these positions, and calibrate as fixed objectives.

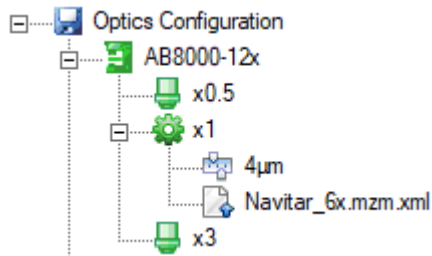

A motorized zoom objective with two fixed calibration positions.x0.5 and x3

**For this to work, the selected optics device must be the motorized objective, identified by the x1**

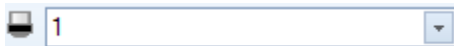

Selection of the motorized objective

NOTE: The virtual fixed objectives MUST be calibrated, interpolation will not work!.

NOTE: Any position, EXCEPT the x1 can be defined as virtual objective. The x1 is used for the motorized objective definition.

NOTE: The precision still depends on the position detection of the limit switches on the motorized objective.

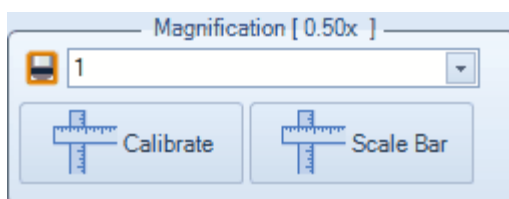

Selection of a magnification with an associated Virtual fixed objective position is indicated with an orange boundary.



## 8.5 Calibration overview

The Optics Editor provides an overview of the calibration status.

The color of the objective icon indicates the status of the objective:

Green – the objective is calibrated.

Yellow – the objective has been calibrated by interpolation from another objective.

Red – the objective is not calibrated.

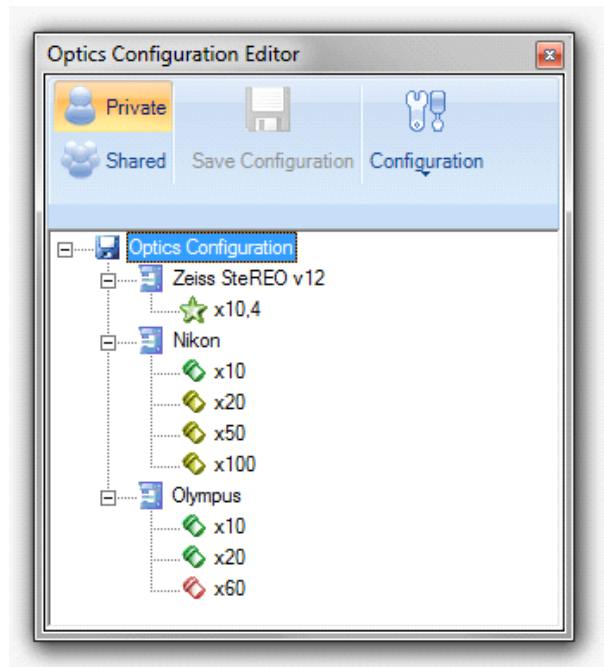

## 8.6 Calibration Backup and Restore

Backing up the calibration files is a good idea.

Backup and restore is also an easy way to move the calibration files from one computer to another.

### 8.6.1 Backing up the Calibration files.

To make a backup of your calibration files, follow this procedure.

Open the Optics Configuration Editor.

Click the 'Backup configuration'.

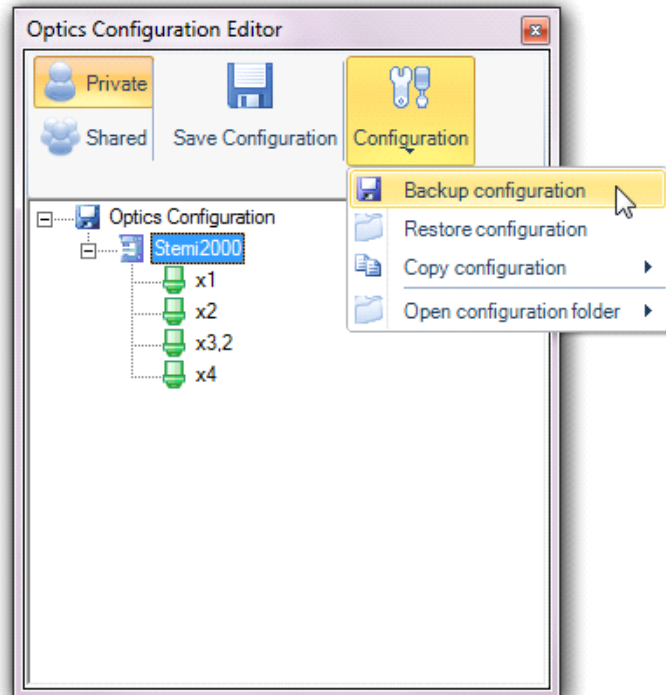

Browse for a directory to store the calibration files. The files can be stored anywhere, e.g. on a portable USB memory.

In this example the files will be stored on the D: drive.

It is convenient to create a new directory for each backup – click the 'Make New Folder' button.

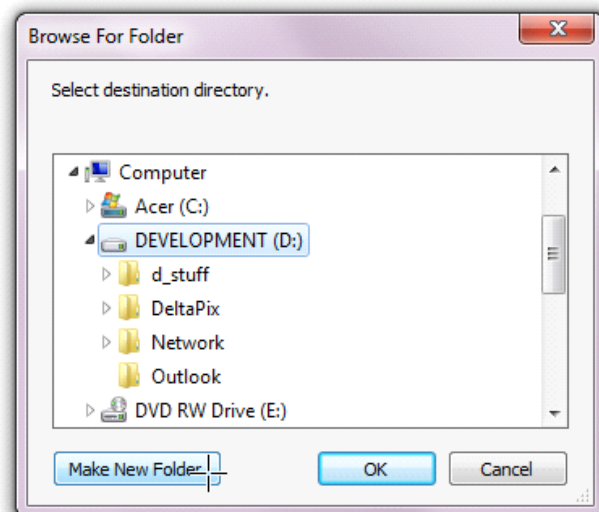

Name the new directory.

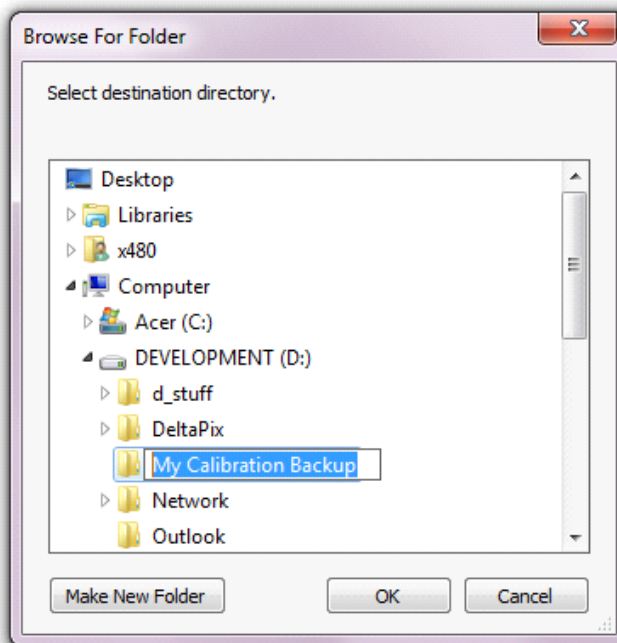

Mark the directory, click OK – the calibration files will be stores almost instantly...  
All done....

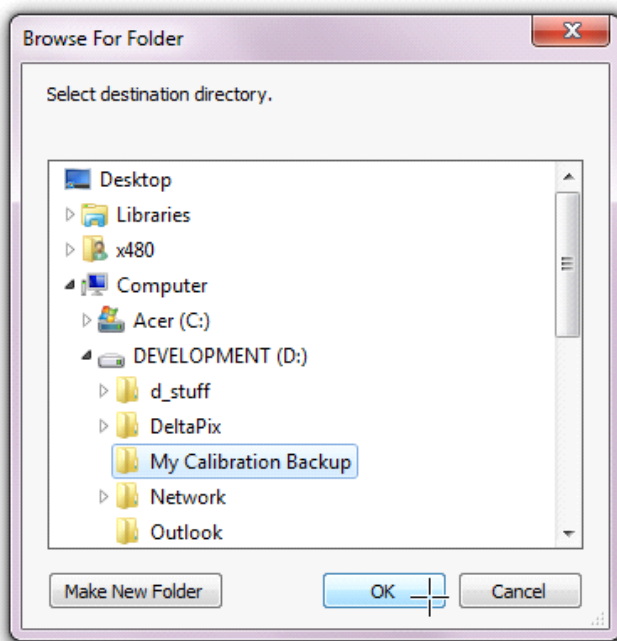

## 8.6.2 Restoring the Calibration files.

### Restoring the Calibration files.

To restore the calibration files (maybe on another computer), follow this procedure carefully.

Open the Optics Configuration Editor.

Click the 'Restore configuration'.

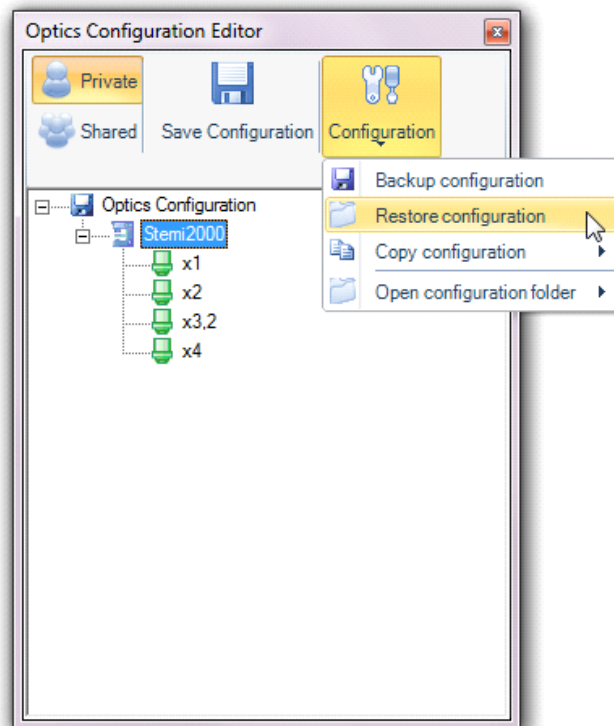

Browse for the directory holding the calibration files (a directory made during a calibration backup).

In this example the files are present on the D: drive in a directory named 'My Calibration Files'

Select the directory, and click OK.

All done....

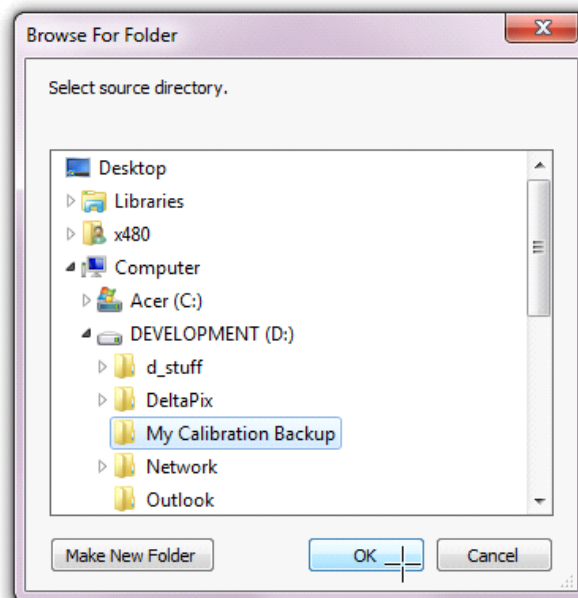



## 8.7 Scale Bar

A Scale Bar can be inserted in the lower right corner of an image. This can be done automatically immediately after image capture as described in section 'Capture Still Image', or manually afterwards.

Click the **Scale Bar** button to see the options.:

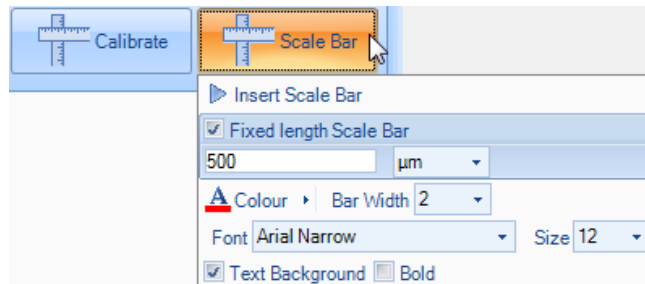

The Insert **Scale Bar** will manually insert a Scale Bar.

Check the **Fixed Length Scale Bar** to insert a scale bar of fixed length, as specified (in this example 500 µm). Un-checking the **Fixed Length Scale Bar** will insert a variable length Scale Bar – length is automatically scaled to fit the image.

The colour of the bar and font can be set.

The font type and size can be set.

A semi transparent text background and bold style can be selected to make the text more readable.

## 8.8 Walton and Beckett graticule

The Walton and Beckett graticule is used for counting fibrous dust (e.g. asbestos or glass fibers) and is particularly useful where the majority of fibers to be counted are shorter than 5 micron. The circle on the Walton & Beckett graticule represent 100 microns at the stage. The circle is divided into four by two diametrical lines scaled in units of 5 and 3 microns respectively. 3 and 5 microns are the critical measurements of fiber lengths used in fiber counting.

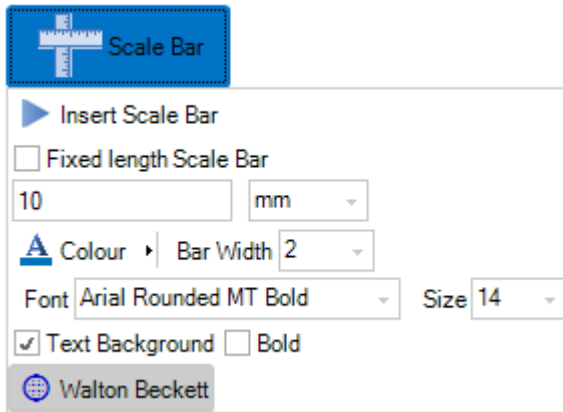

Click the 'Walton + Beckett' to insert. This can be done on live or still images.

The graticule will use the system calibration, an re-size accordingly.

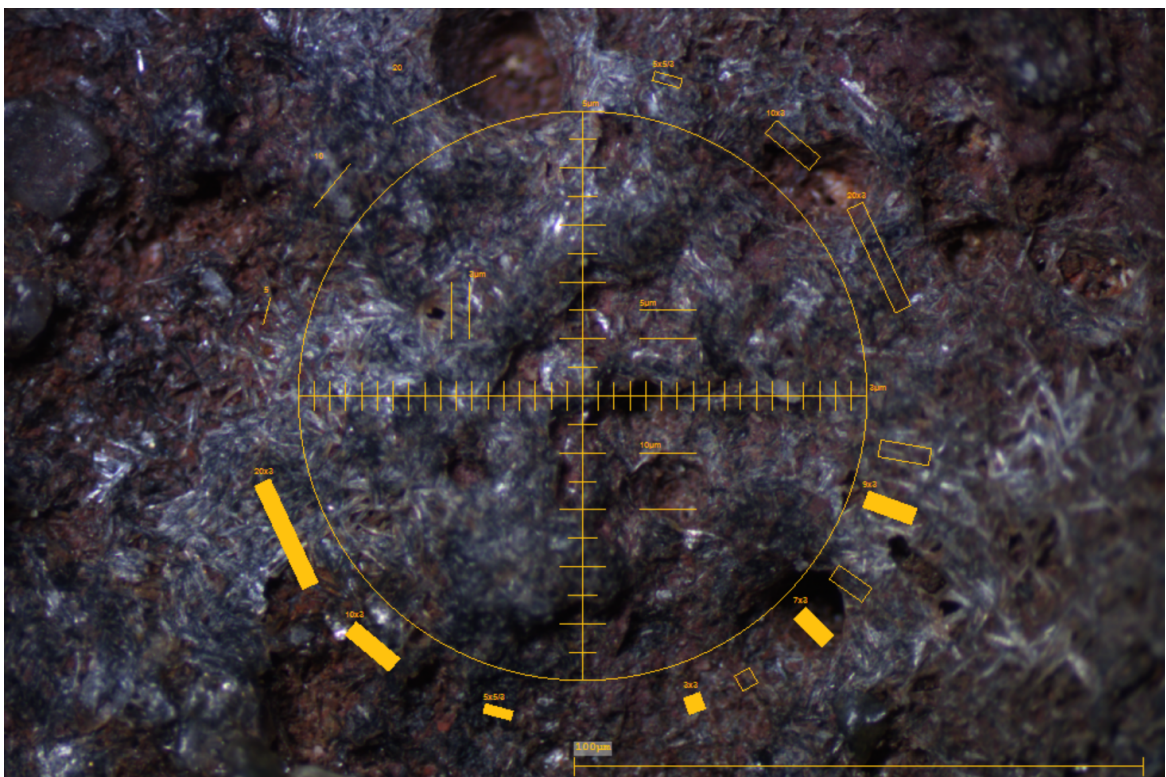

Example of a 'Walton + Beckett'.

## 8.9 Calibrating a motorized Zeiss MTB zoom objective

The DeltaPix InSight supports important functionality from the Zeiss MTB microscope manager.

This section describes the calibration of e.g. a Discovery SteReo V12/V16/V20

- Controlling and read the Focus – allowing Extended Focus and Autofocus.
- Controlling and read of the Zoom – allowing very easy calibration.
- Detection of objective change, the software can automatically switch to another calibration.

### 8.9.1 Defining the microscope

Open the 'Optics Configuration Editor'

Right click the root 'Optics Configuration'

Add the microscope – in this example a 'Zeiss SteREO v12'.

Click 'Add'

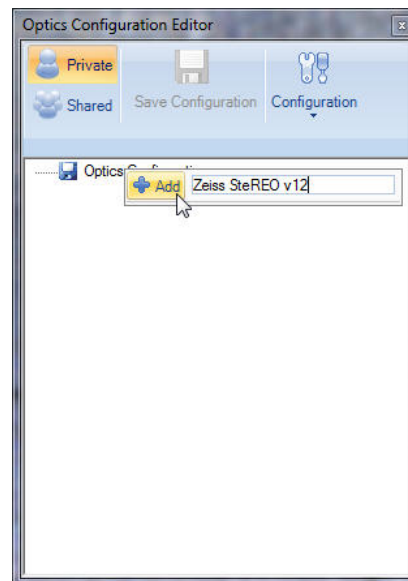

## 8.9.2 Defining the microscope magnification

Right click the freshly added microscope.

Enter the actual magnification read from the 'Zoom Automation' panel (or from the Zeiss SyCoP).

In this example the magnification is 10.4, a more precise magnification can be read by hovering the magnification, see just below:

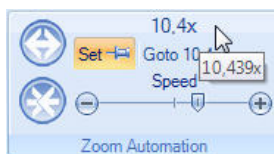

Enter the magnification.

Click 'Add'

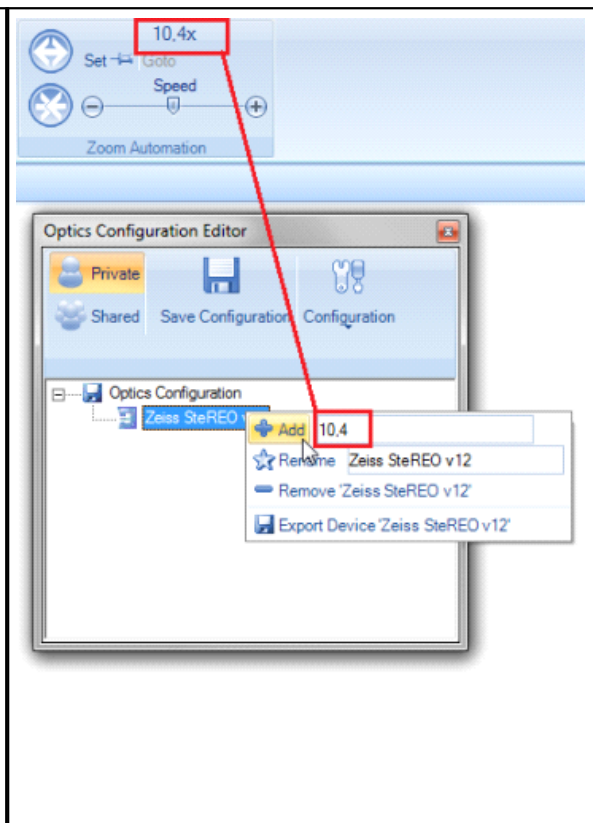

If using an encoded nosepiece with more objectives, then the objectives **MUST** be defined in order – first position 1, then position 2 etc.

The objective will appear in red, indicating that it has not yet been calibrated.

Click 'Save Configuration'.

Close the 'Optics Configuration Editor'

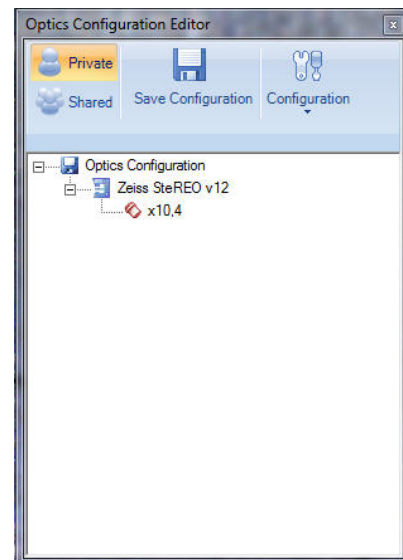

### 8.9.3 Calibrating the motorized objective

#### Calibrating the motorized objective

To calibrate, draw a calibration ruler.

The 'Motorized Objective' checkbox must be checked.

Enter the correct 'Ruler Length'.

Click the 'Calibrate this optics objective'.

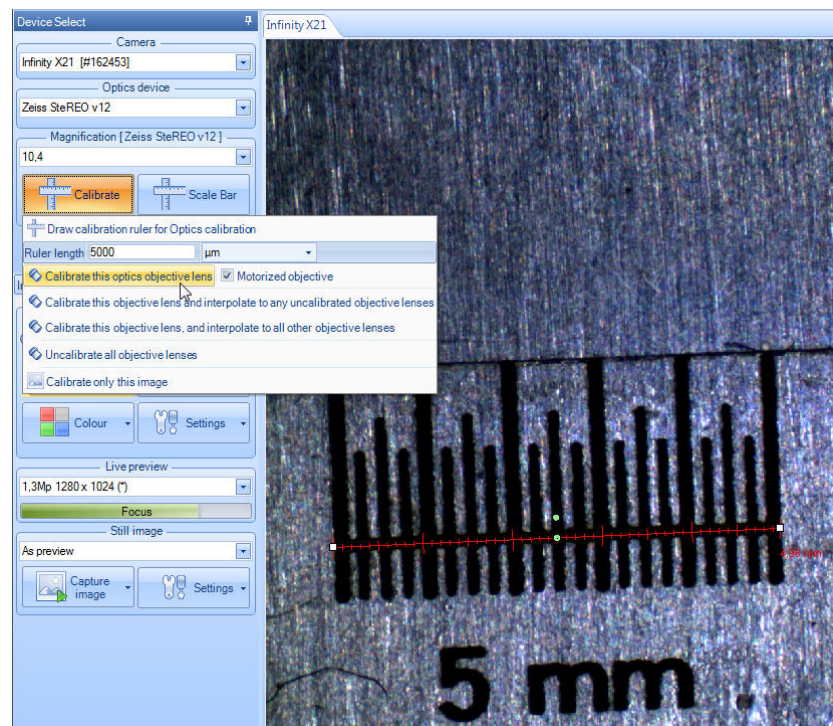

In the Open the 'Optics Configuration Editor' the objective will now appear as a 'star', showing that this is a motorized objective with read back of the zoom.

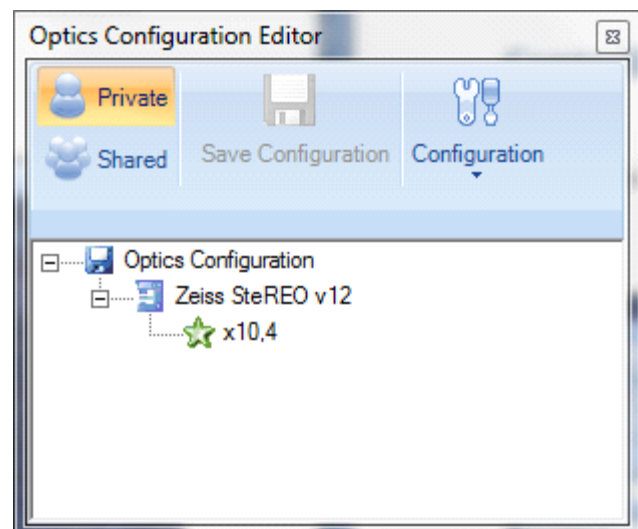





If using an encoded nosepiece with more objectives, then the objectives **MUST** be defined in order – first position 1, then position 2 etc.

## 8.9.4 Controlling the microscope

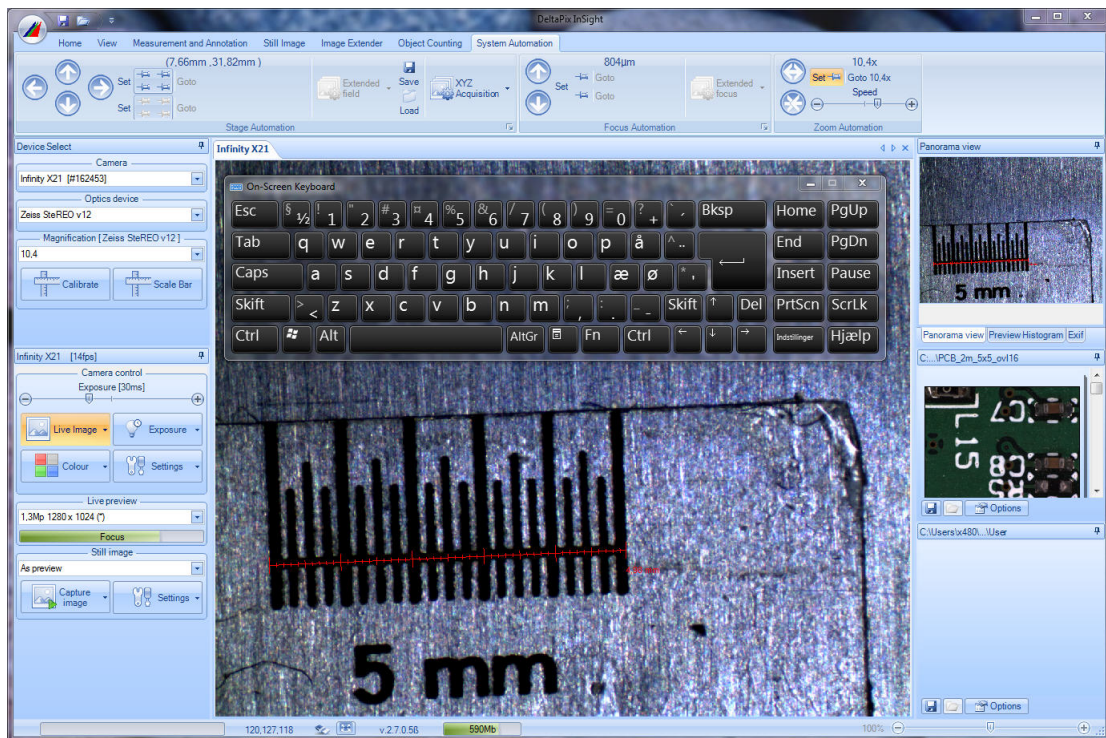

The microscope can now be controlled using the buttons in the 'System Automation' panel. The focus can also be controlled by the 'PgU' and 'PgDn' keyboard buttons.

## 8.10 Sharing Calibrations

Calibrations are stored on a per-user basis.

In some cases, it is advantageous to copy calibrations from one user to another. This section describes how to do this.



The names of the directories may vary depending on your regional language.

The actual location of the Calibration directory may be different depending on your operating system.

### 8.10.1 For the user with a complete calibration

When calibration has been done for one user, the calibration files must be copied to the other user.

Find the directory holding the calibration data. Click the 'Open Application Data Directory' button.

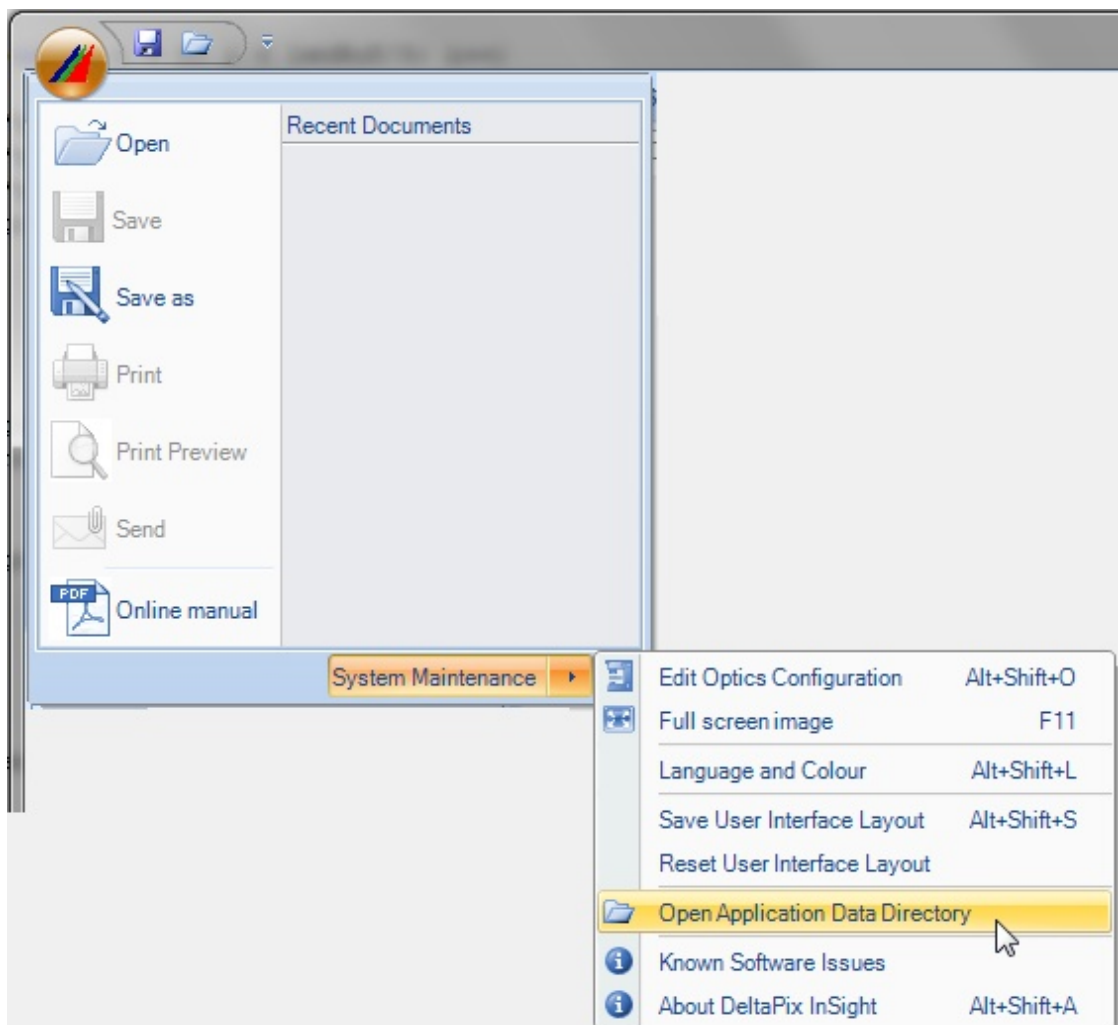

A dialog will open; showing the directories belonging to the actual user, in this (Windows 7) example the user is named 'x480'.

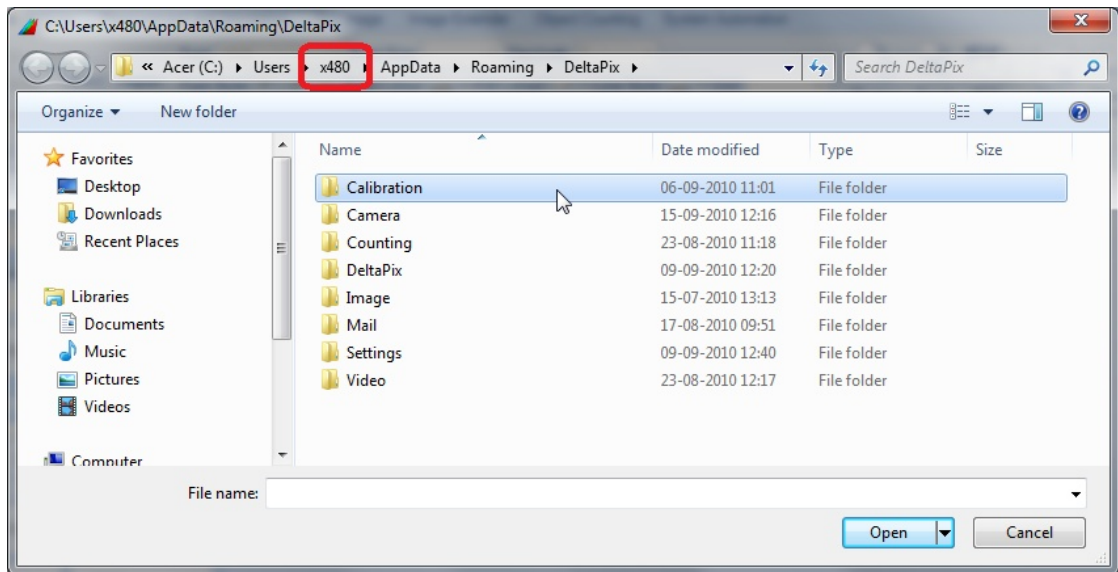

Copy the Calibration directory to a convenient place, like a USB memory stick.

Close the DeltaPix InSight

### 8.10.2 Copy the calibration to another user

Start the DeltaPix InSight from another user account, in this example named 'User1'.

Open the directory holding the calibration data. Click the 'Open Application Data Directory' button.

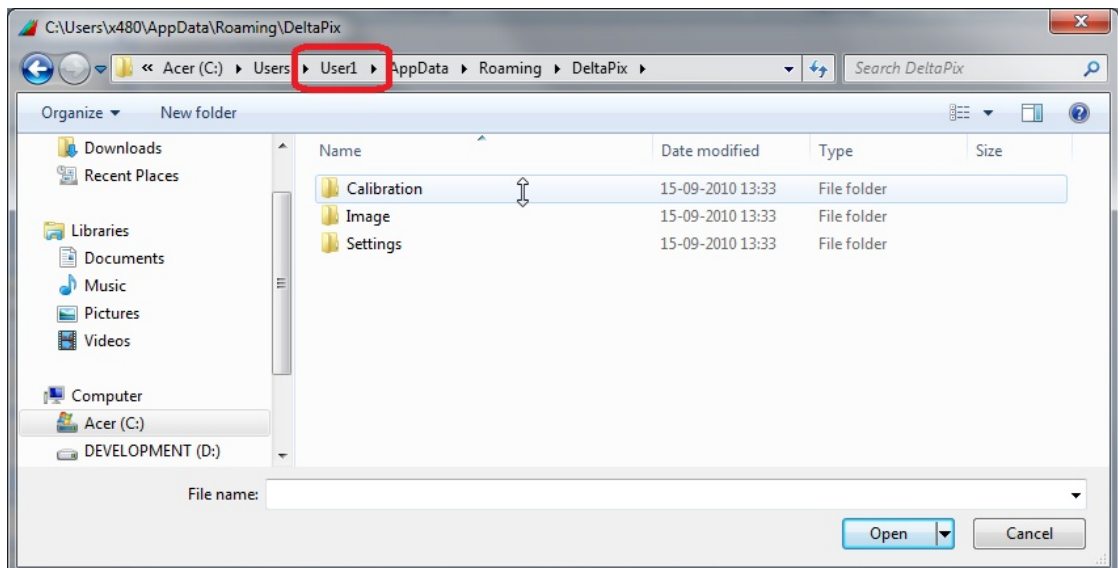



Copy the Calibration directory (from e.g. the USB memory stick) to the directory, overwriting the existing Calibration directory.

You may need to restart DeltaPix InSight to make the calibration take effect.

## 9 The Home Tab

The **Home** tab contains the selection of font tools and tabs arrangement tools.

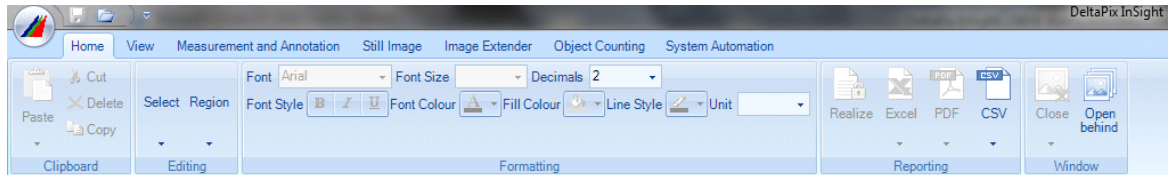

### 9.1 The Editing Tools

The editing tools can be used to highlight a selected area. The selected area can be copied, pasted. And dragged  
A selected rectangular area can also be used for cropping.

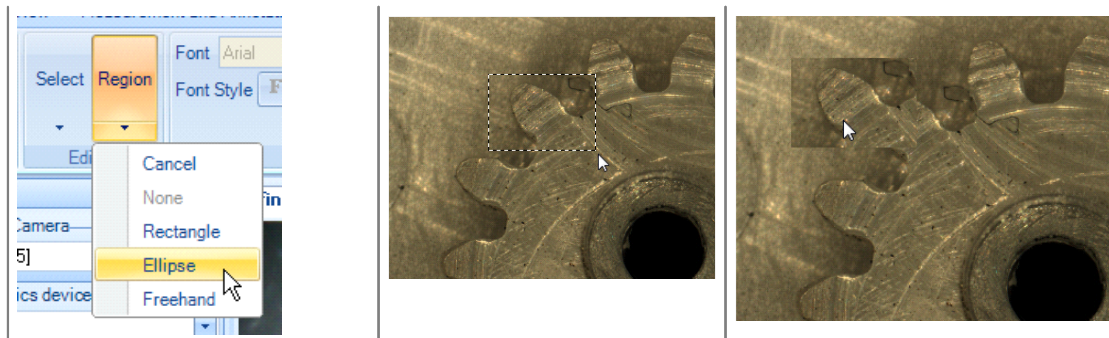

### 9.2 The Formatting Tools

These tools set the colour, font line widths, and more for the annotations and measurements.

### 9.3 Reporting

A distributable report – a report that can be read without using the InSight software – can be generated.

An annotated image can be made into a report in several ways:

Realize: The annotation can be 'burned' into the bitmap.

Excel report: The image is inserted into an Excel spreadsheet, measurements are also inserted.

PDF report: The Excel report can be converted to a PDF document.

CSV report. A comma separated file containing measurement results.

**Note: There is no need for installing Microsoft Excel or a PDF printer; all conversions are done within the InSight software.**

### 9.3.1 Realize

Use the **Realize** to burn the annotations into the image. This allows viewing of annotated images in most commercial image viewers.

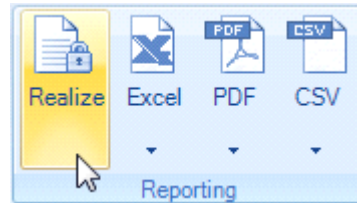

### 9.3.2 Excel Report

A report can be generated in Excel format. This allows for further processing in the spreadsheet. The reporting uses an Excel template, defining the layout of the report. Image, measurement results and other information is placed in the spreadsheet by identifying tags.

A template must be defined, click the **Template** button in order to navigate to a template.

After a template has been defined, simply click the **Excel report** button.

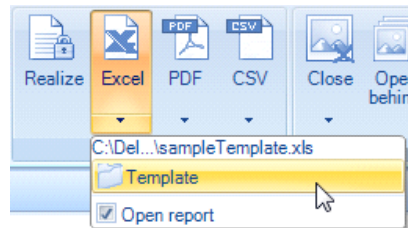

Valid tags are:

%IMGS% defines the upper-left corner of image.

%IMGE% defines the lower-right corner of image.

%MEAS% defines column for measurement results.

%UNIT% defines column for measurement units.

%DATE% defines date.

%TIME% defines time.

%CAMERAMODEL% defines camera model.

%PICTUREDPI% defines the image DPI.

%COL% makes a color marker in the color of the annotations text color.

### 9.3.2.1 Sample Excel Report template

Example of report template, showing usage of most reporting tags.

MyCompany name

MyDepartment

[www.mycompany.com](http://www.mycompany.com)

Report type

Date: 6. november 2006 Project no.: 1234567

Initials: nnn Report no.: 12345



Page 1 of 1

%IMGS%

%IMGE%

%HEAD%			
Comment	Value	Unit	Color
%COMM%	%MEAS%	%UNIT%	%COL%

Date: %DATE% Time: %TIME%

This file: %FILE%

In folder: %FDIR%

Image: %IMAGE%

In folder: %IDIR%

Camera: %CAMERAMODEL%

Picture Width: %PICTUREWIDTH%

Picture height: %PICTUREHEIGHT%

Picture DPI: %PICTUREDPI%

Pix/mm: #####

Picture Taken: %PICTURETAKEN%

### 9.3.2.2 Sample Excel Report output

The resulting report contains image and measurement results.

MyCompany name  
MyDepartment  
[www.mycompany.com](http://www.mycompany.com)

Report type

Date: 6. november 2006 Project no.: 1234567  
Initials: nnn Report no.: 12345

Page 1 of 1



Comment	Value	Unit	Color
	1954	µm	■
	1926	µm	■
	1952	µm	■

Date: 2016:04:16 Time: 20:29:02

This file: Buttons.xls  
In folder: C:\Users\Niels\AppData\Roaming\DeltaPix\Buttons.xls

Image: ztqt5nas.jpg  
In folder: C:\Users\Niels\AppData\Roaming\DeltaPix\Image\ztqt5nas.jpg

Camera: Invenio-6EIII  
Picture Width: 1536  
Picture height: 1024  
Picture DPI: 3302 Pix/mm: 130

Picture Taken: 2016:04:16 08:28:08

Note that the colors of the annotations can be exported to the report, and make understanding easier.

### 9.3.3 PDF Report

To make distribution very easy and flexible, a report can be published as PDF.

The **PDF report** generates a report, using the Excel template, and converts it to PDF.

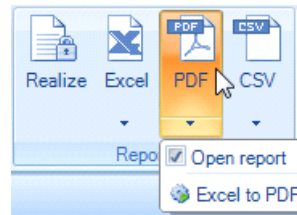

### 9.3.4 Comma Separated Value Report

Alternatively measurement data can be appended to a flat comma separated value (CSV) file. Such a data file can be imported in various programs for further data analysis.

The dropdown defines the CSV:

The name of the report.

Data can be appended – data from several images and measurements in the same file.

The separator can be defined.

A timestamp can be written with each measurement result.

The file can be viewed.

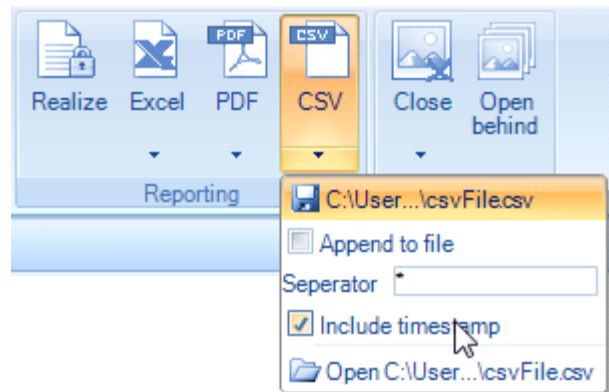

### 9.3.5 Exporting CSV data to Microsoft Excel

To export measurement data, first setup the data format.

- Set the name of the file to export into – click the floppy-disc button.
- If many measurements are to be exported to the same file, check the 'Append to file' check-box.
- Select the data separator, the ';' (Semicolon) is recommended.
- A time stamp can be included
- If system automation is used, the XY position can be added.

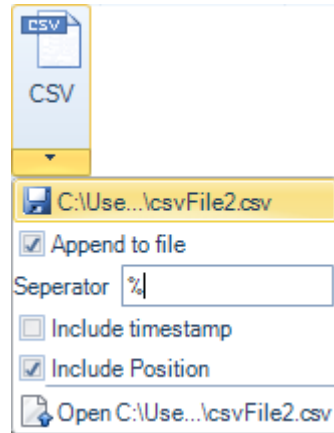

Now measurements can be defined on a still image or even at the live image.  
Now each time you click the 'CSV' button (Shortcut F12), the measurement data is exported to the data file.

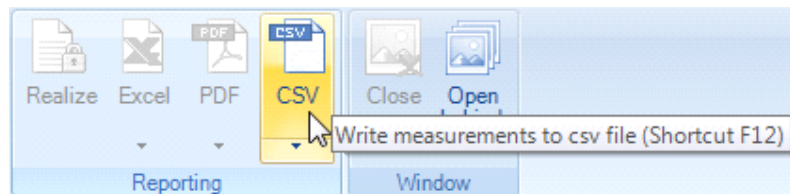

Hint: Data can be written using the F12 shortcut.

Hint: To have easy and convenient access to the CSV buttons, they can be added to the QAT band.

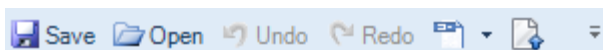

### 9.3.5.1 The Comma Separated Value file.

This is an example of the data in the CSV file.

It contains three measurement sessions.

Each session contains time stamp, XYZ position [um] five measurement results (two angles, and three distances)

```

2019:05:28 07:45:28;888.984375;um;-798.203125;um;-
3531.5625;um;16.55;°;34.17;°;158.64;mm;221.74;mm;189.47;mm
2019:05:28 07:45:47;888.984375;um;-798.203125;um;-
3531.5625;um;24.46;°;27.86;°;119.28;mm;185.91;mm;162.65;mm
2019:05:28 07:46:14;930.3125;um;-798.203125;um;-
3506.484375;um;31.66;°;21.14;°;143.55;mm;151.49;mm;140.42;mm

```

Note: Angular measurements will always be first measurements, the rest in order of creation.



### 9.3.5.2 Import to Microsoft Excel 2007

There are several ways to import the data into Excel.

One way to import data into Microsoft Excel: click on **Data**, then click the **From Text** button in the **Get External Data** menu. This will bring up the **Text Import Wizard**. In the first step, make sure you have **Delimited** set as the first option.

You can also select which row you would like to start from. In this example, we're doing the whole thing starting with the first row.

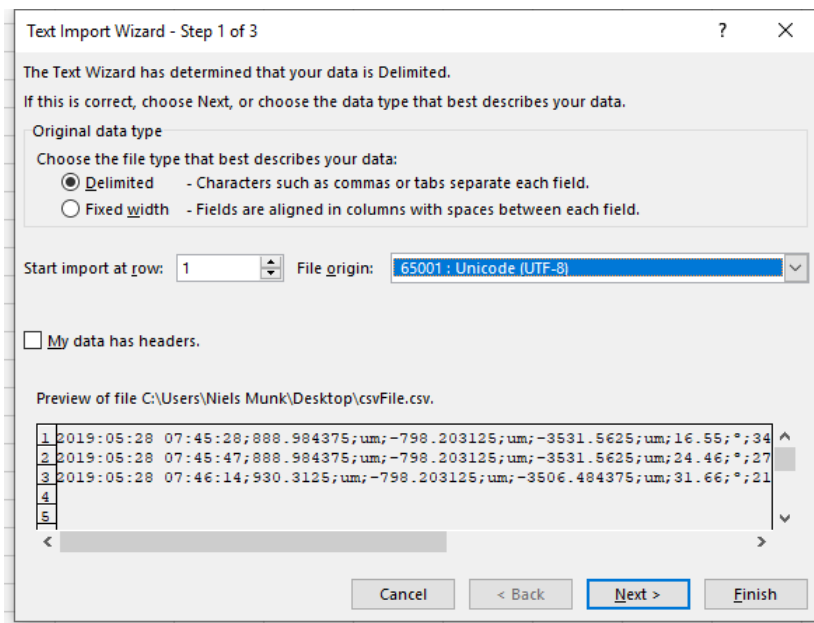

The example data are separated using the ';'.  
This will then show your data in columns at the bottom.

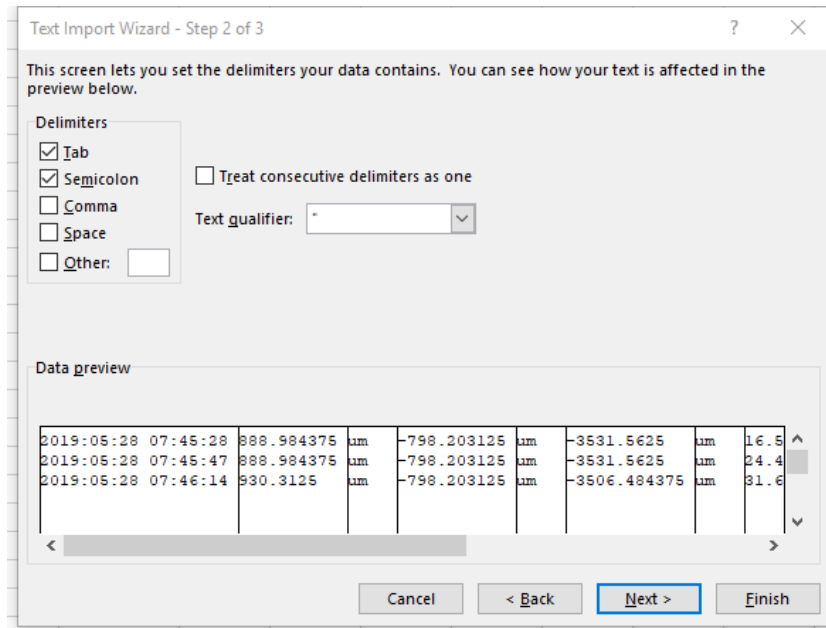

The third step simply lets you choose the format of the data, such as numbers, text, or dates. After you've done that, just click **Finish** and the data will be imported into your spreadsheet.

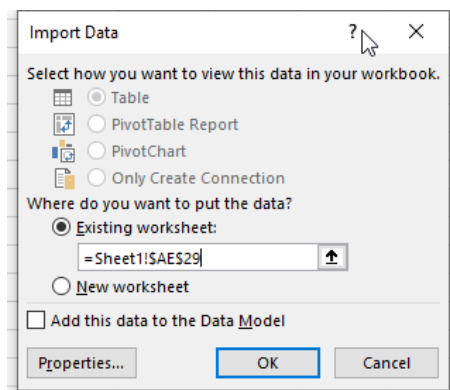

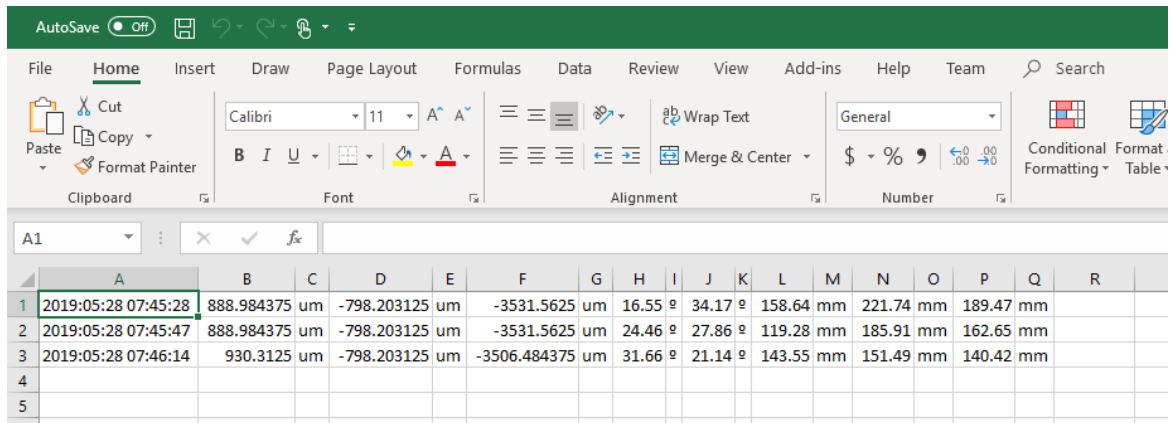

## 9.4 The Window tools

The **Close** button can be used to close all still images. The dropdown allows closing images only of a specific type, e.g. Extended Focus images.

The **Open behind** button makes sure that new images are opened behind the live preview image. This is a useful feature for e.g. manual and automatic Extended Focus.

## 10 The View tab

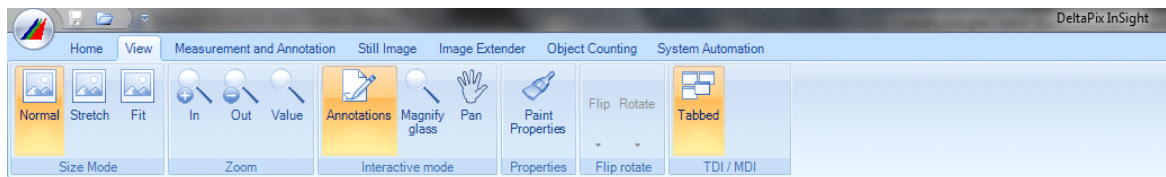

This tab holds functions for image viewing, e.g. fit, stretch, zoom etc. Properties and Flip rotate function are adjustment tools for captured images. TDI / MDI switches between two types of arrangements for image viewing.

### 10.1 Image Tile

In the View tab, there is an option for arranging images in an easy way.

Toggle tabbed - MDI View (Ctrl-Shift-T)

Tile Vertical (when in MDI view) (Ctrl-Shift-V)

Tile Horizontal (when in MDI view) (Ctrl-

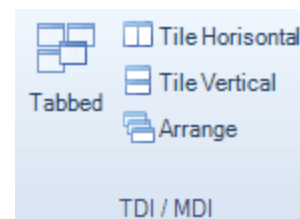

Shift-H)

Arrange (when in MDI view) (Ctrl-Shift-A)

## 11 The Measurement and Annotation tab

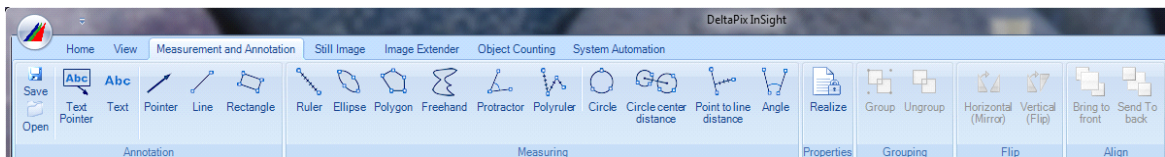

Use the Formatting tools from Home to change the font/line colour or size of the annotations or measurements.

### 11.1 Annotation

Annotations are notations added to the live preview or to a captured image. Choose the type of annotation in the **Basic** menu, then draw on the image:

Use the formatting tools from **Home** to change font/line.

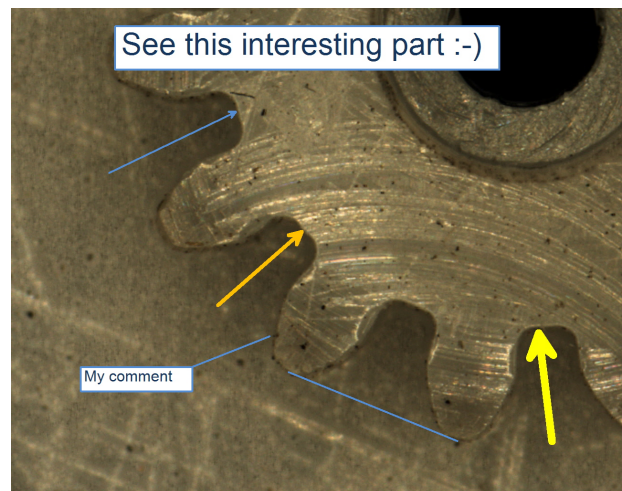

## 11.2 Measurement

This is a tool for measuring distances, area, circle properties and angles.

To measure choose the tool, then draw on the image:

The calculated results will automatically show next to the drawing. Use the formatting tools from **Home** to make font/line adjustments as desired.

To repeat a measurement type without mouse clicking on the measurement again, press the space bar.

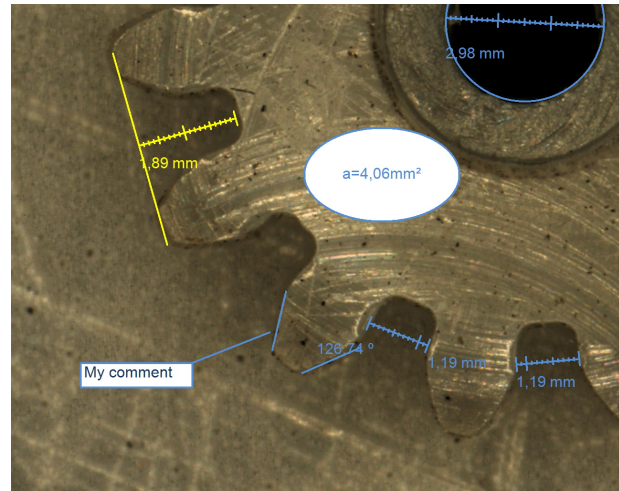

### 11.2.1 Polygon and Freehand result options

The Polygon and Freehand tools can measure area and/or perimeter. The selection is done in the drop-down - as shown below.

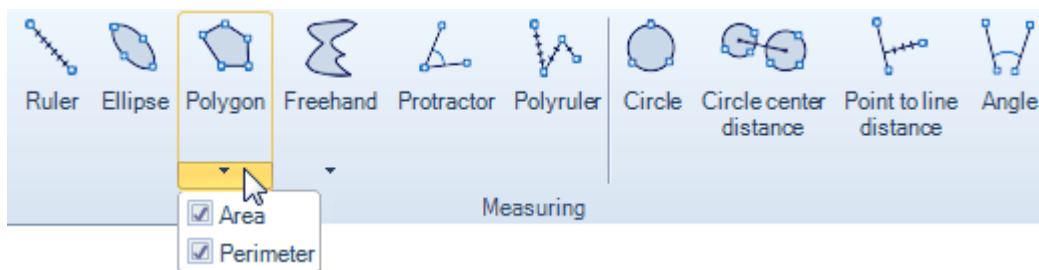

### 11.2.2 Circle measurement result options

The circle measurement can display either radius, diameter or perimeter as measurement result.

Selection is done via the drop down menu of the Circle button.



### 11.2.3 Flexible position for measurement result

For most measurements, the measurement result can be moved around, independent of the position of the measurement tool.

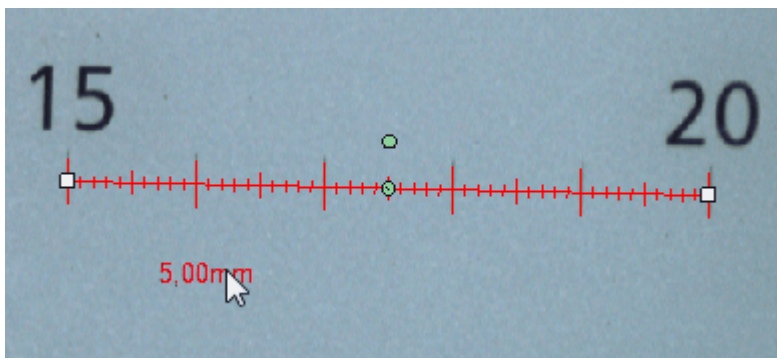

Drag the measurement data using the mouse.

## 11.3 Save the Annotations and Measurements

There are several ways of saving the annotations and measurements.

### 11.3.1 Save and Open the Annotations only

Annotations from an image can be saved without saving the image. This is useful if some complicated annotation is used on several images. The annotation can be opened and applied to another image.



### 11.3.2 Save the Annotations and Measurements in Separate Files

This is done in the same way as saving an image; see section 'Save Image'. The annotations and measurements belonging to the image will appear automatically when using InSight to open and view this image, and editing is possible. Other image viewers will only show the original image without the annotations and measurements.

One of the ways to save the file is to click on the **disk button** located in the galleries. Hereby, the image and the measurements and annotations will be saved in separate files.



### 11.3.3 Save the Annotations and Measurements in the Same File

Another way is to save the image and the annotations and measurements in one file:

The program will burn the annotations and measurements on the original image, so a new image is created. In this way the annotations and measurements will no longer be editable.

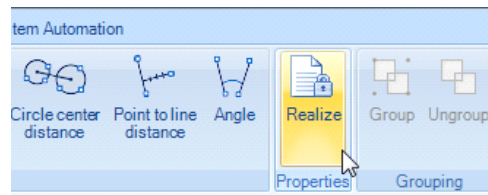

## 12 The Still Image Tab

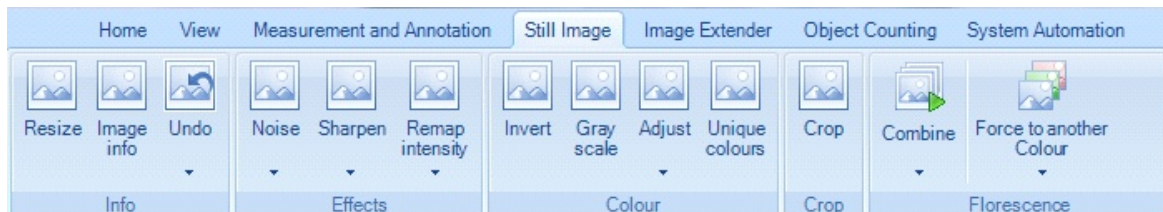

In the **Still Image** menu there are several adjustment tools available for changing the specifications of a captured image. There are functions for noise removal, intensity remapping and much more.

### 12.1 Undo

Operations done in the 'Still Image' panel can be undone. There are two possibilities, undo the most recent operations or undo all operations and revert to the original image.

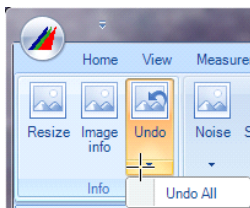



The shortcut for undo is 'Ctrl-Shift-Z'.

## 12.2 Remap Intensity

In some cases it is desirable to be able to remap the pixel intensities. This can remove some kind of noise or increase the contrast.

The 'Remap Intensity' button has two options, 'Remap Intensity' or 'Remap Intensity Settings'. The 'Remap Intensity' used the settings from the 'Remap Intensity Settings'.

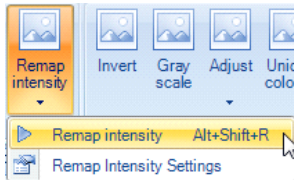

The 'Remap Intensity Settings' opens a panel with several adjustments.

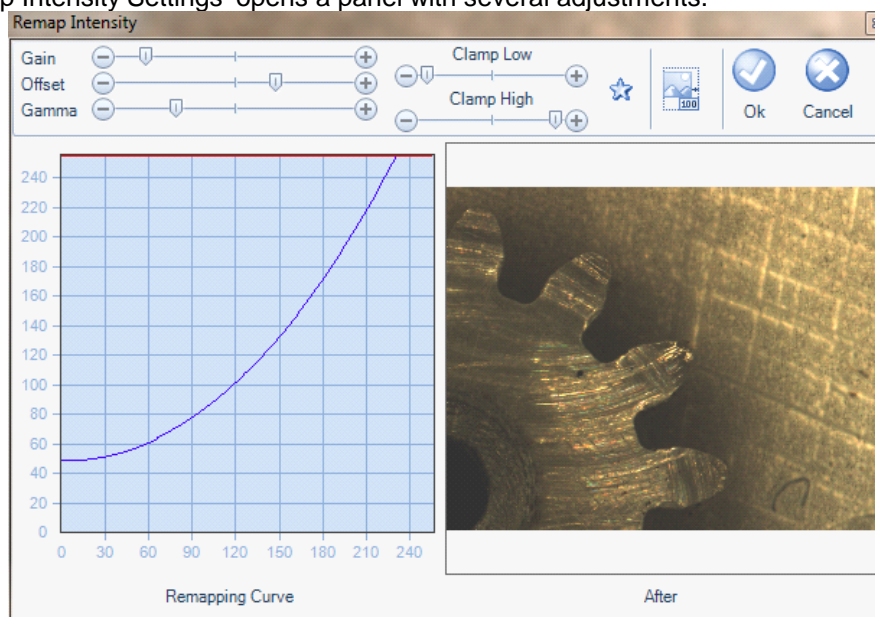

The star button resets the settings to default, a 1:1 mapping.

The 100% button shows the 'After' image in its real size; use the mouse for manoeuvring around.



### 12.3 Fluorescence

Images captured can be fake colored and combined. This is useful when dealing with fluorescence images captured with a monochrome camera.

An image can be forced to another colour using the dropdown menu as shown here:

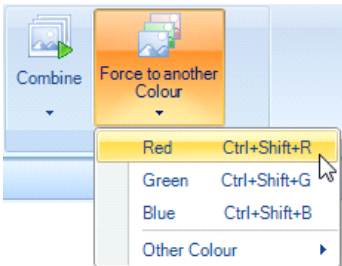

The images can then be combined; a good result is achieved using the **Maximum** option.

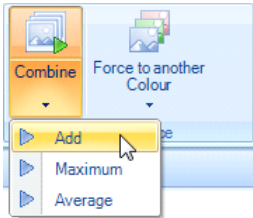

This is an example of combining two fluorescence images; one fake coloured to green, the other fake coloured to red.

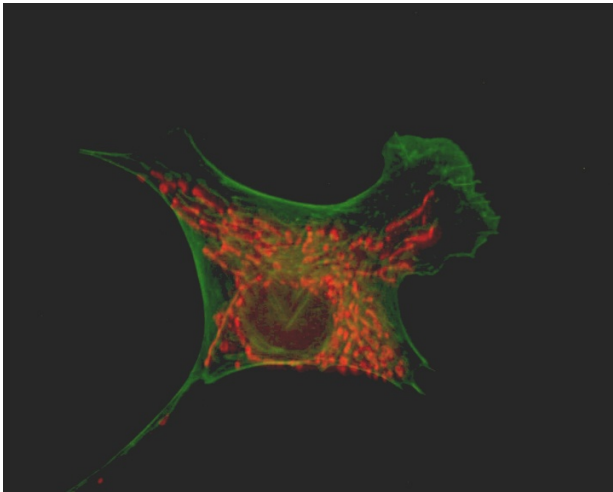
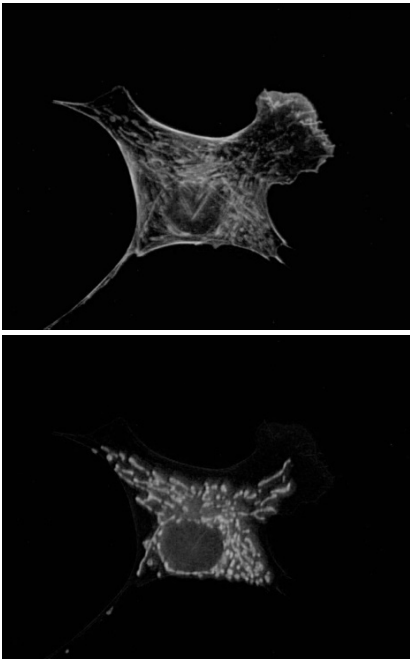

## 12.4 Deconvolution – Lucy-Richardson algorithm

Functions perform image deconvolution. They can be used for restoring the degraded image, in particular image that was obtained by applying the convolution operation with known kernel. (Iterative method) [Ric72]. Border pixels of a source image are restored before deconvolution.

For further reference to the Lucy- Richardson method:

W.Richardson. Bayesian-Based Iterative Method of Image Reconstruction. Journal of the Optical Society of America, vol.62, No.1, January 1972.

Note that to deconvolve an image, the image should NOT be saturated.

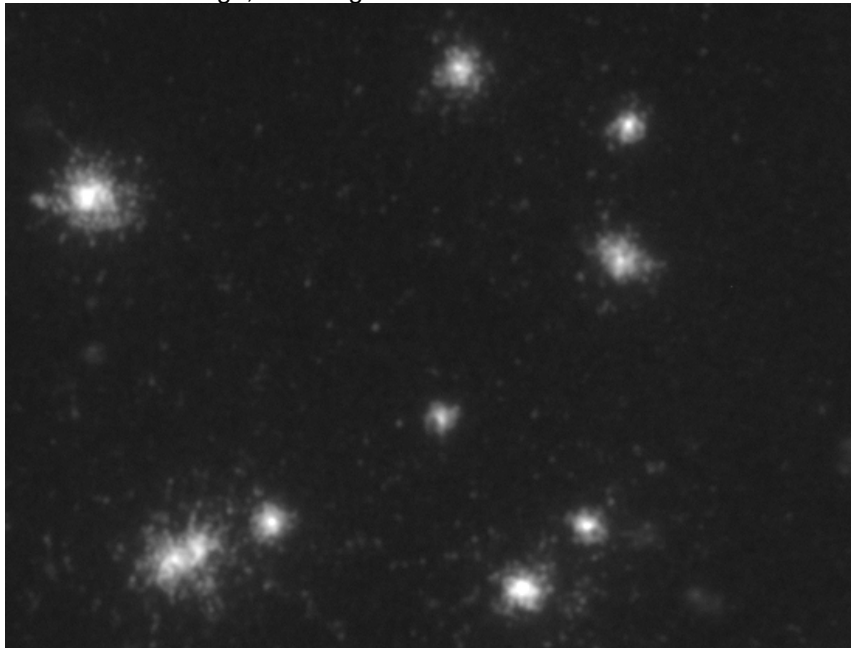

Example of blurred image

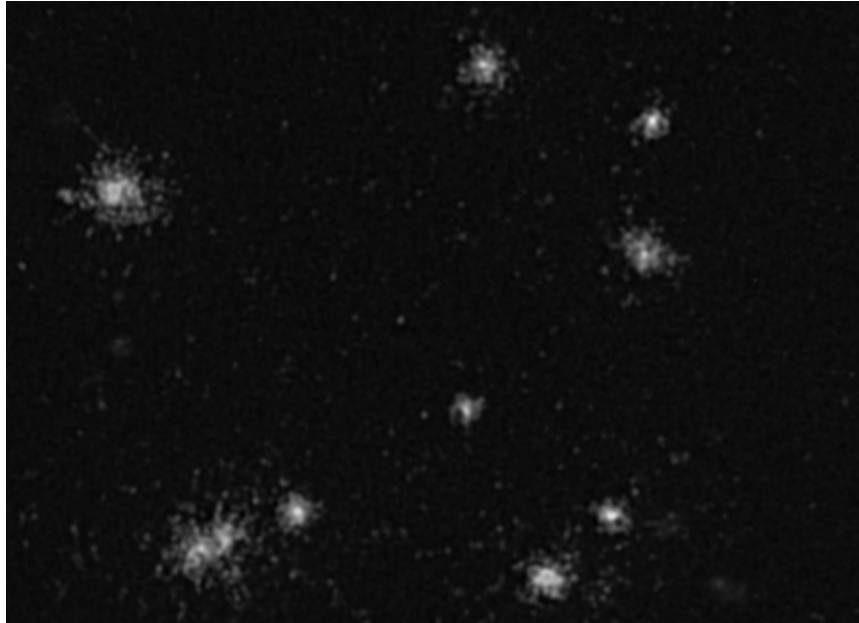

After applying the deconvolution, some details now appear clearer.

## 13 The Image Extender Tab

The **Extended Focus** and **Extended Exposure** functions can create an image, where multiple depths and multiple exposures are all in focus at once by putting the different layers together to one image.

Images can also be combined using **Extended Field** (a.k.a. stitching).

The tab also has the option for **Extended Time Recording** (a.k.a. Time lapse recording).

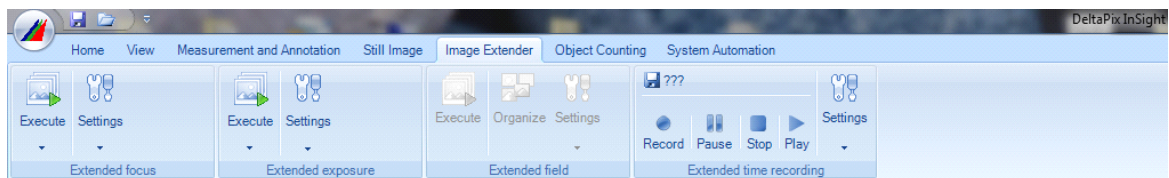

### 13.1 Manual Extended Focus

InSight has a state of the art Extended Focus function.

Both manual and automatic Extended Focus is possible. The automatic function uses the motor automation.

Capture several images from top to bottom of the different focus levels, (increase or decrease focus with as equal intervals as possible):

Then select **Execute**. The progress bar will show the ongoing work.

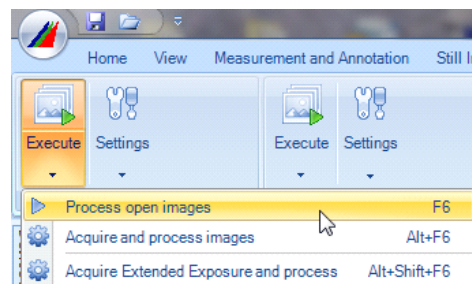

Live preview



Extended Focus image

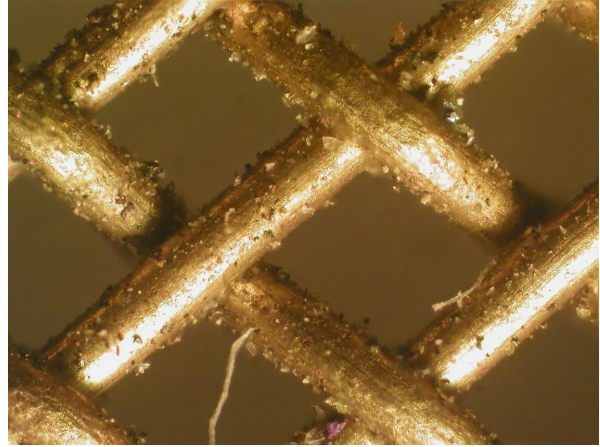

Note: Using many large size images may cause the process to run out of memory.

## 13.2 Extended Exposure

Extended Exposure combines multiple images, each captured with different exposure time and thus having only a part of the image correctly exposed.

Select in **Settings** the amount of images desired (max. five), then select the different exposure percentages:

Now, select **Execute** and the Extended Exposure image will appear after a short while.

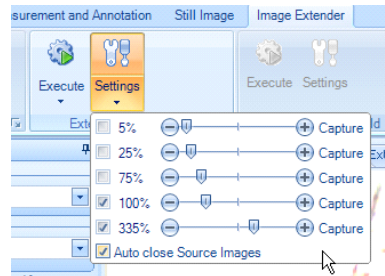

Live preview:

Extended Exposure image:

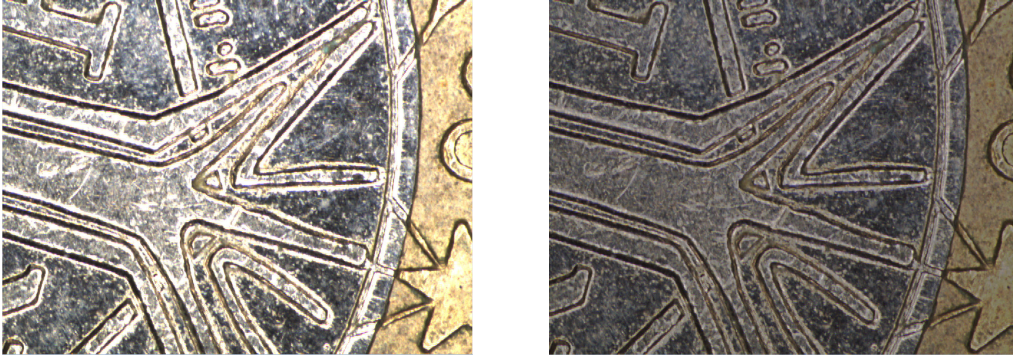

### 13.2.1 Contrast post processing

The merging of several images acquired at different exposure time sometimes degrades the contrast.

In such cases it may be useful to do an automatic contrast enhancement.

Check the 'Contrast post-processing' check box.

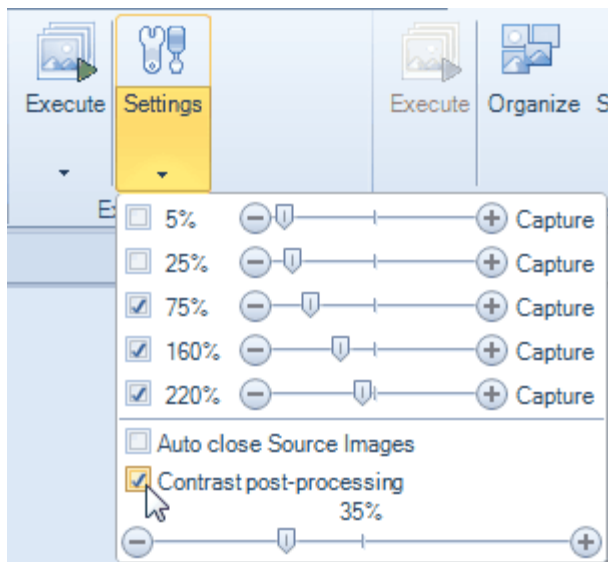

The slider sets the degree of contrast enhancement - a value around 35% often leads to a very good result.

## 13.3 Manual Extended Field

Images captured using e.g. a manual XY stage can be combined using the Extended Field tool. With the intuitive user interface manual, stitching of single captured images can be performed fast and precise. Simply define the number of rows and columns and drag the images from the directory to the graphical guide and press the execute button to perform the stitching.



It is very important that the images are carefully aligned horizontally and vertically – if not the resulting image will be poor or wrong.



To combine the images select the number of rows and columns. The overlap between the images must be set to the overlap of the acquired images (at least 10% is recommended).

**Deviation** is the 'uncertainty' of the overlap.

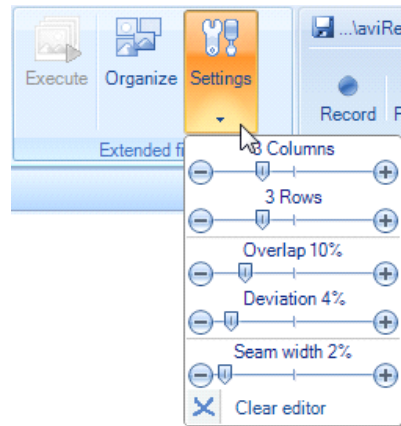

Next, click the **Organize** button and drag images from a gallery to the **Extended Field editor**.

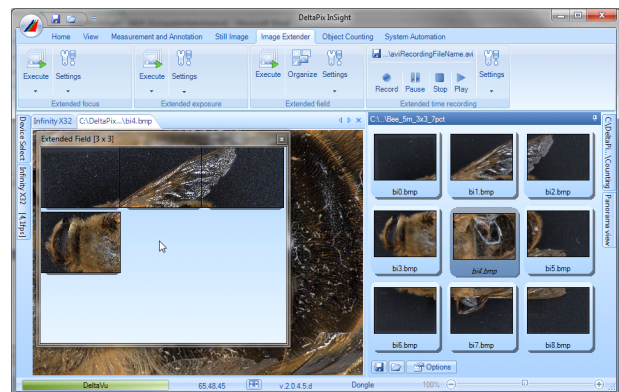

Images can be re-arranged within the editor by dragging. This example shows how to swap the position of two images.



When the images have been arranged, click the **Execute** button. Note that combining the images may take a while.

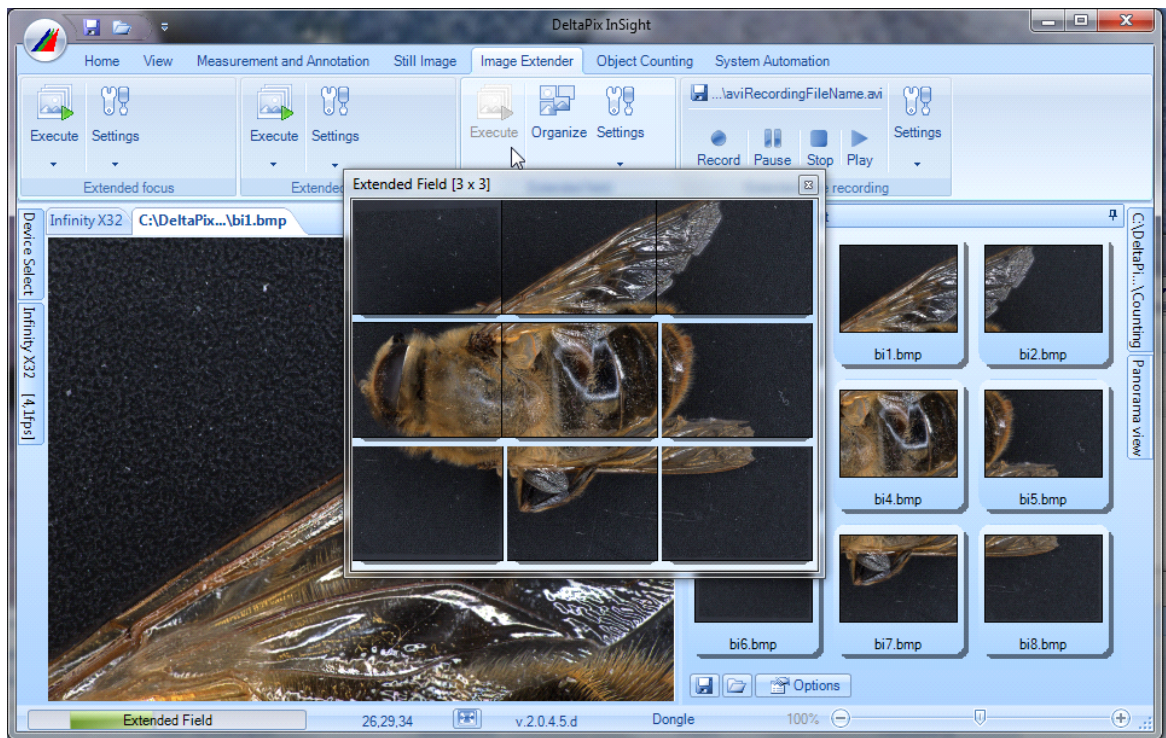

Using many large size images may cause the process to run out of memory.

## 14 The Counting Tab [from v6.1.18]

The counting tab holds all controls to set up a counting session.

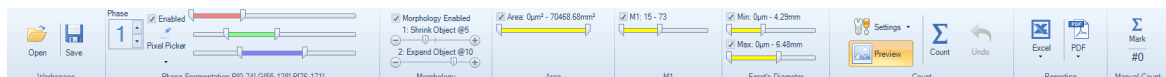

The counting utilizes up to four phases.

A phase is defined by a set of features, like color range and geometrical features.

The geometrical features can be:

- Individual for each phase. This makes counting of objects with different geometrical features possible.
- Shared. This means that all phases use the same geometrical features. Used when counting objects only segmented by color.

The selection of individual or shared features is done in the settings drop down button, see "Use same features"

## 14.1 Workspace

A workspace can be saved or opened.

This is useful when counting different samples or using different setups.

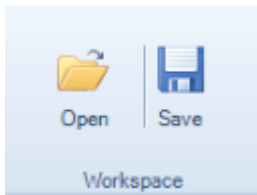

Counting workspace's are saved with file extension cnt.xml, so a workspace could have name like myWorkspace.cnt.xml.

Save workspace

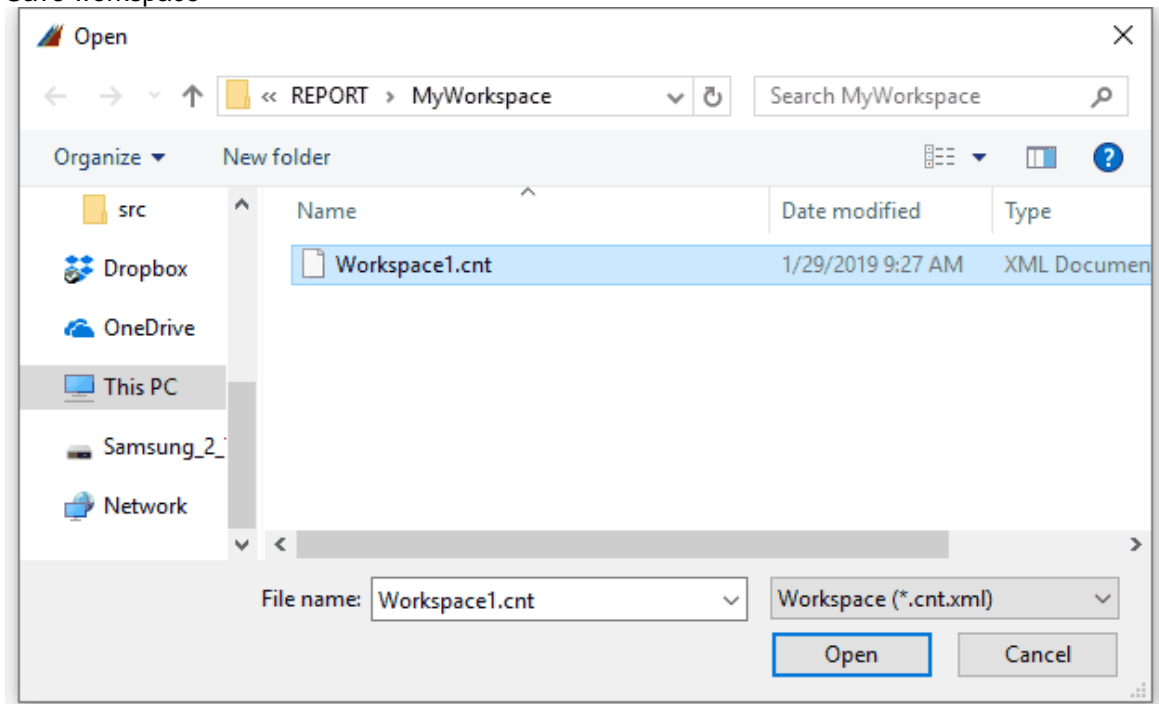

Load workspace



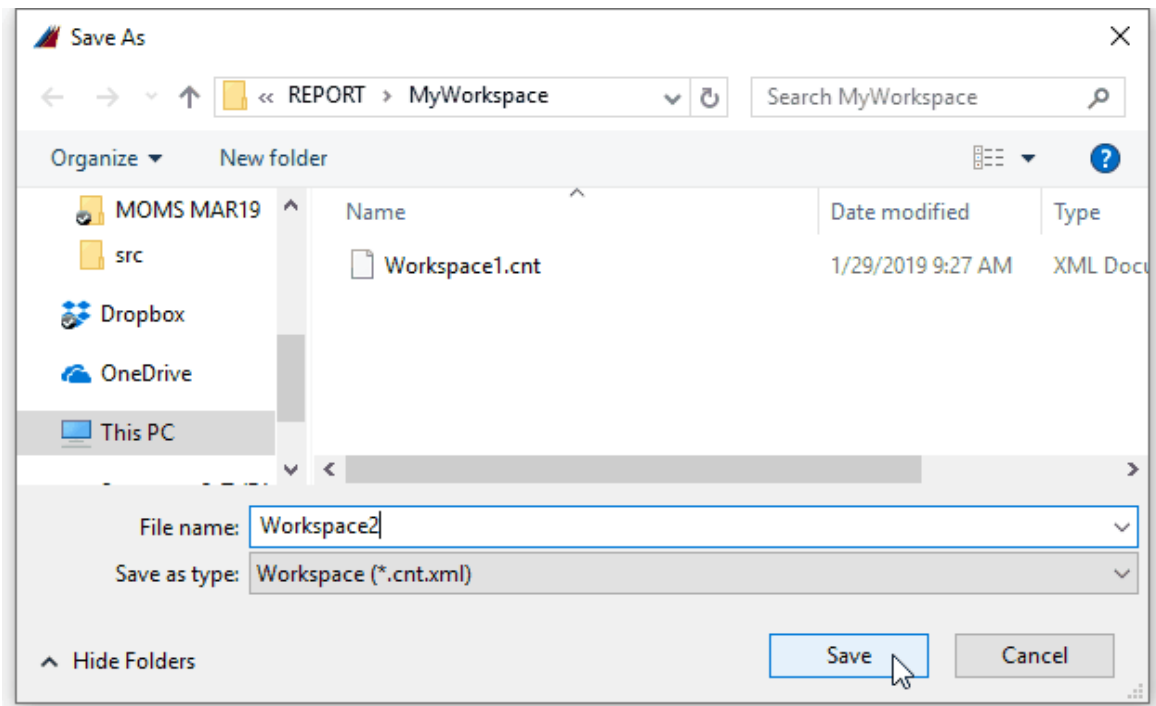

## 14.2 Phase Segmentation

The segmentation is based on threshold RGB ranges.

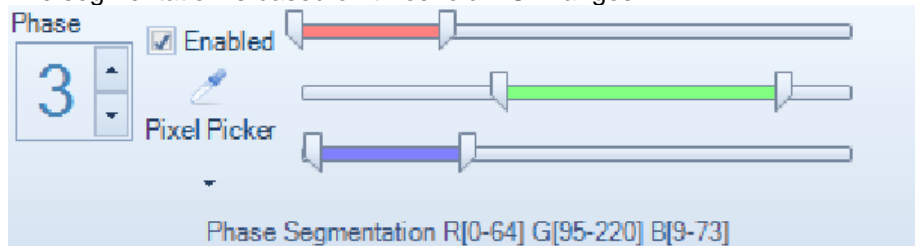

The phase is defined by an RGB range, which can easily be set by three range sliders. In this example phase #3 has RGB range [0-64][95-220][9-73].

### 14.2.1 Pick object color

The threshold range can be set individually for each color channel. Using the color picker, makes it easier to find an appropriate threshold range, some fine tuning may be needed.

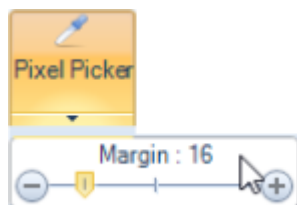

When picking a region, a margin can automatically be added. In this example the lower threshold range will be 16 lower, and 16 higher than the picked value.

### 14.2.2 Phase Definition Overlap

If phases are defined so that the definition ranges overlaps, an exclamation sign is shown next to the sliders.

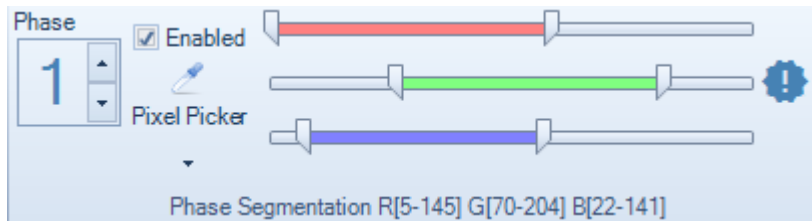

A phase overlap means that a region belongs to more than one phase.

### 14.3 Morphology preprocessing

As a pre-processing option it is possible to do binary morphology – i.e. after doing the threshold.

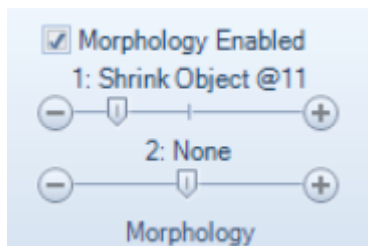

Morphology is useful for removing small artifacts, or disconnecting regions.

Note: Using same shrink and expand level, will approximately preserve the object area.

### 14.4 Area Feature

The counting can use the area as discriminator.

To enable this, check the checkbox, and set the sliders to the area range to include in the counting.

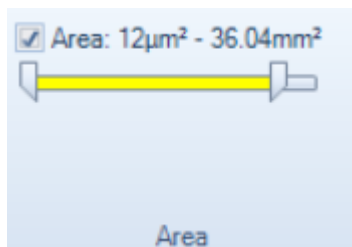

Example: Only objects with an area in the range  $12\mu\text{m}^2 - 36.04\text{mm}^2$  will be included in the counting.

### 14.5 M1 Feature

The counting can use the M1-parameter as discriminator.

The M1 is a size independent moment-based feature describing the compactness of the object.

- A perfect round compact object will measure 15
- A “long stripe” will measure 70+

The enable this, check the check box, and set the sliders to the area range to include in the counting.

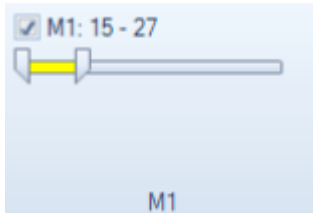

Example: Only objects with an M1 in the range 15 – 27 will be included in the counting. This will exclude “long” objects.

*For more information on the rotation and size invariant M1 feature, please see: Using Image Moments for Tracking Rotating Objects, ARAS 05 Conference, 19-21 December 2005, CICC, Cairo, Egypt, Payman Haqiqat Islamic Azad University (IAU) – Dubai Campus.*

## 14.6 Ferret Feature

The method corresponds to the measurement by a slide gauge.

It is defined as the distance between two parallel tangents of the particle. The minimum Feret diameter is often used as the diameter equivalent to a sieve analysis.

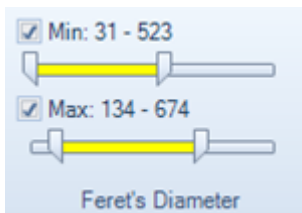

Example: Only objects with an Feret min = 31–523um and max in the range 134–674um will be included in the counting.

These parameters, min and max, can be used to exclude the counted objects via the Ferrets diameter interval.

Please note that the calculation of the min Feret is complicated, and thus a little slow

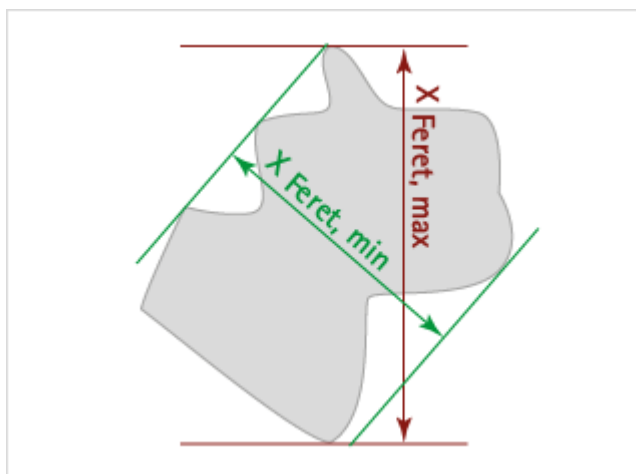

## 14.7 Counting

The Count panel holds a Settings, Preview and Count button.



Clicking the Preview button will preview the actual phase – so that the phase definition can be fine-tuned.

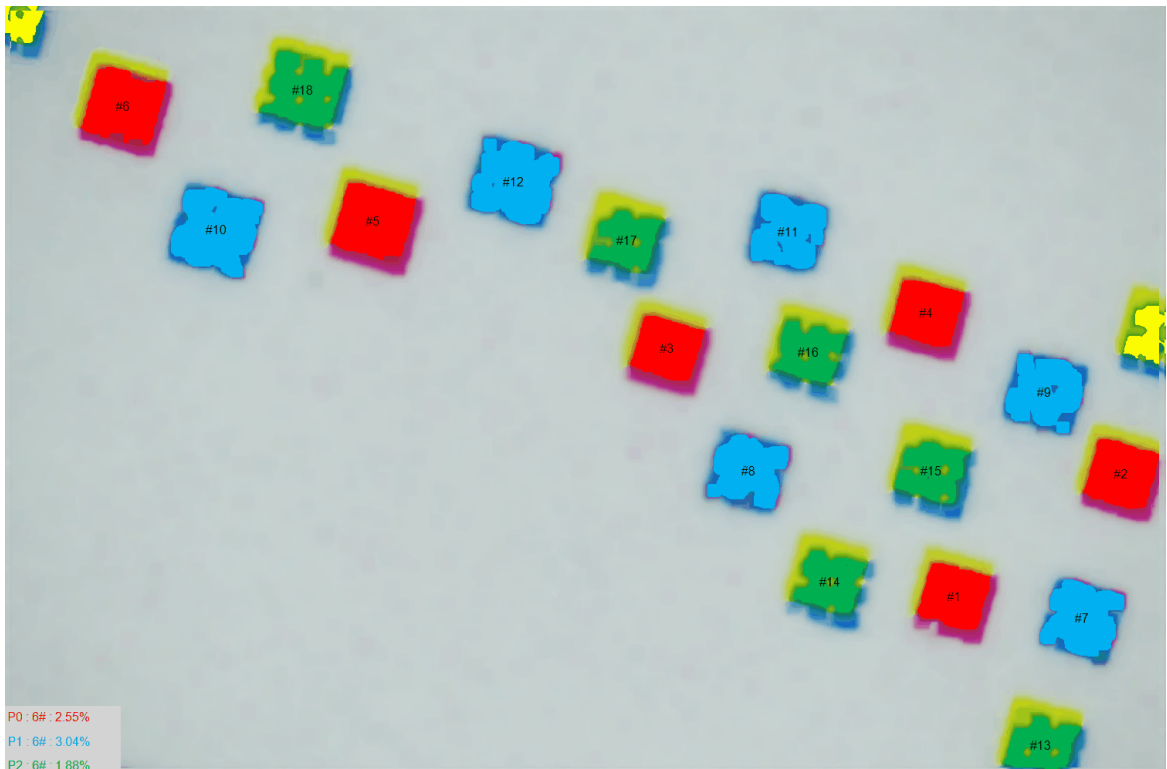

### 14.7.1 Settings

In the settings button drop down, the mark color can be defined.

Each phase color, and the colors for ignored objects can be set.  
Also, the option of ignoring objects touching the image border is set here.

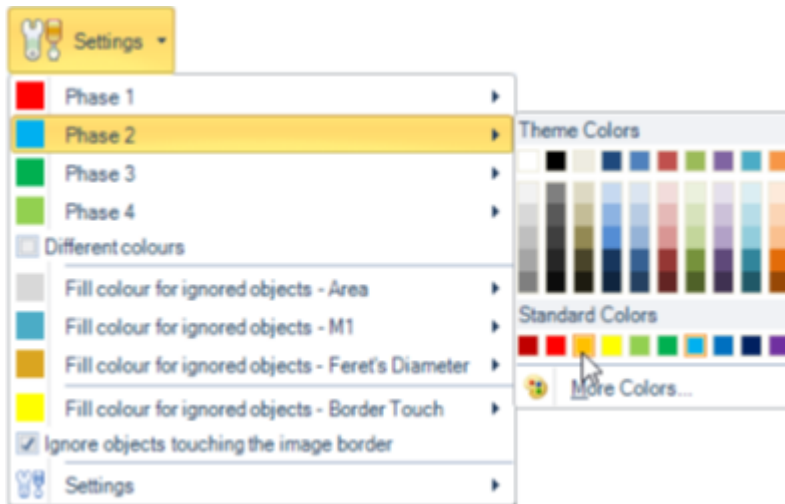

#### 14.7.1.1 Use same features

The geometrical features can be:

- Individual for each phase. This makes counting of objects with different geometrical features possible.
- Use same features. This means that all phases use the same geometrical features. Used when counting objects only segmented by color.

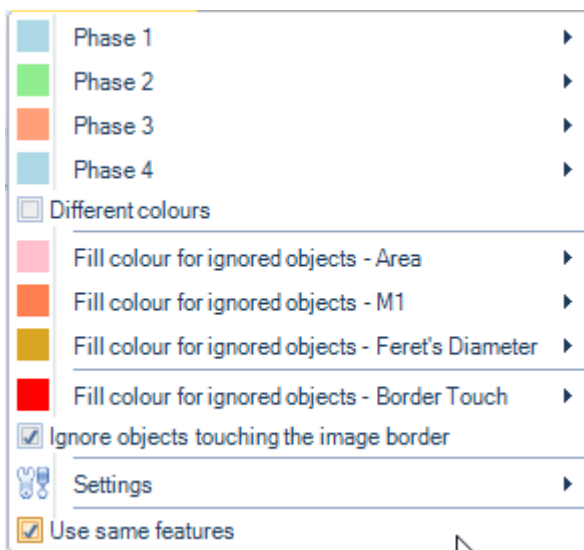

## 14.7.2 Counting Options

The Settings drop out button is defining the basic result presentation

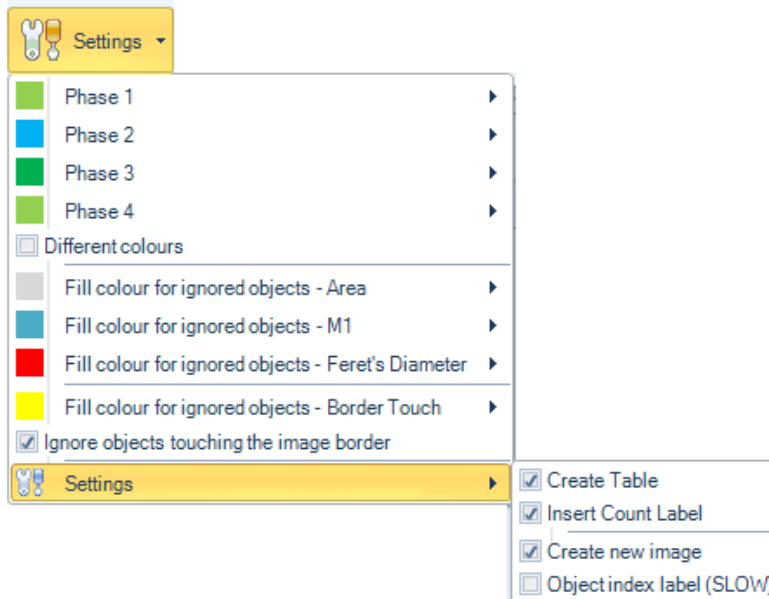

### 14.7.2.1 Create Table

Checking this, will make a table pop-up with detailed counting data when the Count button is clicked.

Counting-32406

#	Phase [#]	Phase [%]	Area [ $\mu\text{m}^2$ ]	Angle [°]	FeretMin [ $\mu\text{m}$ ]	FeretMax [ $\mu\text{m}$ ]	M1	Diameter [ $\mu\text{m}$ ]
1	1	0.381	592.91	26	529.17	712.34	16	592.91
2	1	0.415	618.17	19	556.3	746.26	16	618.17
3	1	0.372	585.71	27	508.81	712.34	16	585.71
4	1	0.388	597.84	27	529.17	732.69	16	597.84
5	1	0.508	684.05	34	610.58	848.02	16	684.05
6	1	0.489	671.08	70	624.15	848.02	17	671.08
7	2	0.480	664.90	23	624.15	841.24	17	664.90
8	2	0.440	637.03	53	603.79	820.89	17	637.03
9	2	0.458	649.97	52	630.93	827.67	17	649.97
10	2	0.618	754.84	51	719.12	909.08	16	754.84
11	2	0.454	646.94	43	617.36	793.75	17	646.94
12	2	0.593	739.03	40	691.99	881.94	16	739.03
13	3	0.282	509.45	16	461.32	739.48	19	509.45
14	3	0.302	527.37	43	488.46	712.34	18	527.37
15	3	0.302	527.37	10	495.25	719.12	18	527.37
16	3	0.299	525.03	40	488.46	705.56	18	525.03
17	3	0.274	502.68	57	481.68	712.34	19	502.68
18	3	0.419	621.25	38	583.44	848.02	18	621.25

Table with detailed counting information. The color in the leftmost column is the same as used to colorize the individual phases.

### 14.7.2.2 Insert Count Label

Checking this, will insert a basic label in the lower left corner of the counting image with the number of objects and the area percentage for each active phase.



### 14.7.2.3 Create New Image

Will create a new counting image from the still or live preview image. Otherwise the still image will be overwritten.

### 14.7.2.4 Object index label

Checking this, will insert a counting number on each object. Please note that this feature is very slow, and when counting many objects it will add significantly to the processing time.

## 14.8 Reporting

A report can be generated in Excel format. This allows for further processing in the spreadsheet.

Excel reports can be generated even without a Microsoft Excel installation on the computer. The reporting uses an Excel template, defining the layout of the report. Image, measurement results and other information is placed in the spreadsheet by identifying tags.

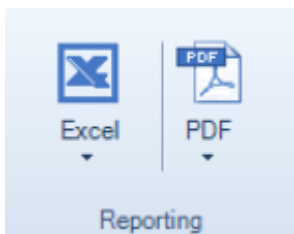

### 14.8.1 Excel

A template must be defined, click the Template button in order to navigate to a template.

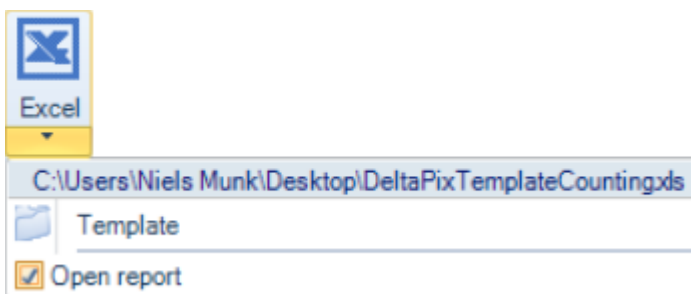

Checking the “Open Report” will automatically attempt to open the Excel report after generation. After a template has been defined, simply click the “Excel” button to create a report from a counting.

### 14.8.2 Template tags

Tags can be inserted in the Excel template document to define the layout of the report.

- %AREA% will insert the area for the object
- %AREA\_UNIT% will insert the area unit for the object
- %M1% will insert the M1 for the object
- %FERRET1% will insert the Feret minimum distance for the object
- %FERRET1\_UNIT% will insert the Feret minimum distance for the object
- %FERRET2% will insert the Feret maximum distance for the object
- %FERRET2\_UNIT% will insert the Feret maximum unit for the object
- %PHASEPCT% will insert the area percentage for the object
- %PHASECOL% will colorize the cell with the actual phase color.
- %PHASEIDX% will insert phase index for the object, i.e. which phase it belongs to.
- %ANG% will insert minimum inertia angle of the object. For compact objects, this of course is unpredictable.
- %ANG\_UNIT% will insert angle unit of the object.
- %DIAM% will insert the diameter of circle with same area as object.
- %DIAM\_UNIT% will insert the diameter unit

### 14.8.3 PDF

To make distribution very easy and flexible, a report can be published as PDF.

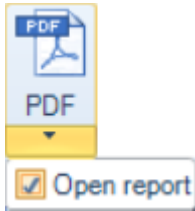

The “PDF” generates a report, using the Excel template, and converts it to PDF. Checking the “Open Report” will automatically attempt to open the PDF report after generation.



MyCompany name  
 MyDepartment  
[www.mycompany.com](http://www.mycompany.com)

Report type  
 Date: 2019.01.29 Time: 10:20:19

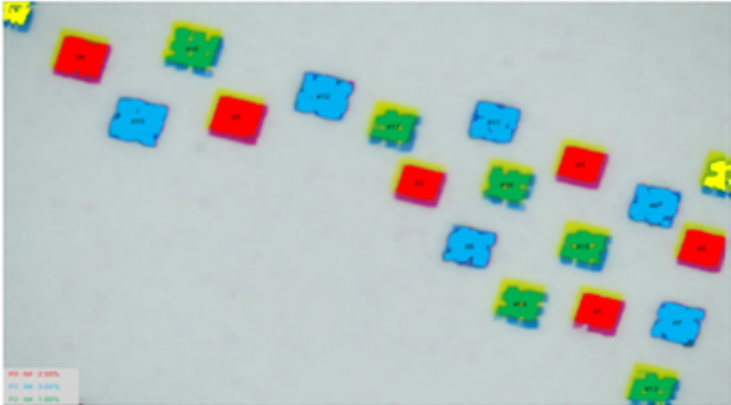
This file NewCountingReport.xls  
 In folder C:\Users\Niels Munk\Desktop\NewCountingReport.xls

Image: NewCountingReport.jpg  
 In folder C:\Users\Niels Munk\Desktop\NewCountingReport.jpg

Camera: Invenio-6EIII  
 Picture Width: 1536  
 Picture height: 1024  
 Picture DPI: 3744  
 Pix/mm: 147  
 Picture Taken: 2019:01:29 10:16:22

Phase1 %	2.553
Phase2 %	3.043
Phase3 %	1.878
Phase4 %	0

Phase	Phase %	Area	M1	Ferret Max	Diameter
1	0.381	592.91 $\mu\text{m}^2$	16	712.3 $\mu\text{m}$	592.91 $\mu\text{m}$
1	0.415	618.17 $\mu\text{m}^2$	16	746.3 $\mu\text{m}$	618.17 $\mu\text{m}$
1	0.372	585.71 $\mu\text{m}^2$	16	712.3 $\mu\text{m}$	585.71 $\mu\text{m}$
1	0.388	597.84 $\mu\text{m}^2$	16	732.7 $\mu\text{m}$	597.84 $\mu\text{m}$
1	0.508	684.05 $\mu\text{m}^2$	16	848 $\mu\text{m}$	684.05 $\mu\text{m}$
1	0.489	671.08 $\mu\text{m}^2$	17	848 $\mu\text{m}$	671.08 $\mu\text{m}$
2	0.48	664.9 $\mu\text{m}^2$	17	841.2 $\mu\text{m}$	664.9 $\mu\text{m}$
2	0.44	637.03 $\mu\text{m}^2$	17	820.9 $\mu\text{m}$	637.03 $\mu\text{m}$
2	0.458	649.97 $\mu\text{m}^2$	17	827.7 $\mu\text{m}$	649.97 $\mu\text{m}$
2	0.618	754.84 $\mu\text{m}^2$	16	909.1 $\mu\text{m}$	754.84 $\mu\text{m}$
2	0.454	646.94 $\mu\text{m}^2$	17	793.8 $\mu\text{m}$	646.94 $\mu\text{m}$
2	0.593	739.03 $\mu\text{m}^2$	16	881.9 $\mu\text{m}$	739.03 $\mu\text{m}$
3	0.282	509.45 $\mu\text{m}^2$	19	739.5 $\mu\text{m}$	509.45 $\mu\text{m}$
3	0.302	527.37 $\mu\text{m}^2$	18	712.3 $\mu\text{m}$	527.37 $\mu\text{m}$
3	0.302	527.37 $\mu\text{m}^2$	18	719.1 $\mu\text{m}$	527.37 $\mu\text{m}$
3	0.299	525.03 $\mu\text{m}^2$	18	705.6 $\mu\text{m}$	525.03 $\mu\text{m}$
3	0.274	502.68 $\mu\text{m}^2$	19	712.3 $\mu\text{m}$	502.68 $\mu\text{m}$
3	0.419	621.25 $\mu\text{m}^2$	18	848 $\mu\text{m}$	621.25 $\mu\text{m}$

DeltaPix InSight

Example of PDF report

### 14.8.4 Excel processing – example calculating the Phase%

The advantage of exporting to Excel, is that further processing easily can be done.

As example:

- If the phase number (by tag % PHASEPCT %) is written to A39. This will write the phase numbers to column A, starting from A39.
- If the phase percentage (by tag %PHASEIDX%) is written to B39. This will write the phase percentage to column B, starting from B39.

Then the total phase percentage for phase "1" can be calculated like "`=SUMIF($A39:$A100, "1", $B39:$B100)`"

Phase	Phase %	Area	M1	Ferret Max	Diameter	
0L%P	%PHASEI	%AREA%	%AREA_L	%M1%	%FERF %FERRET: %DIAM%	%DIAM_UNIT%

Sample template with data processing.

## 14.9 Manual Counting

Some objects can be too difficult to count automatically. The manual counting can be used in such cases.



The 'Mark' button will create a new counting point that can be placed onto the image.

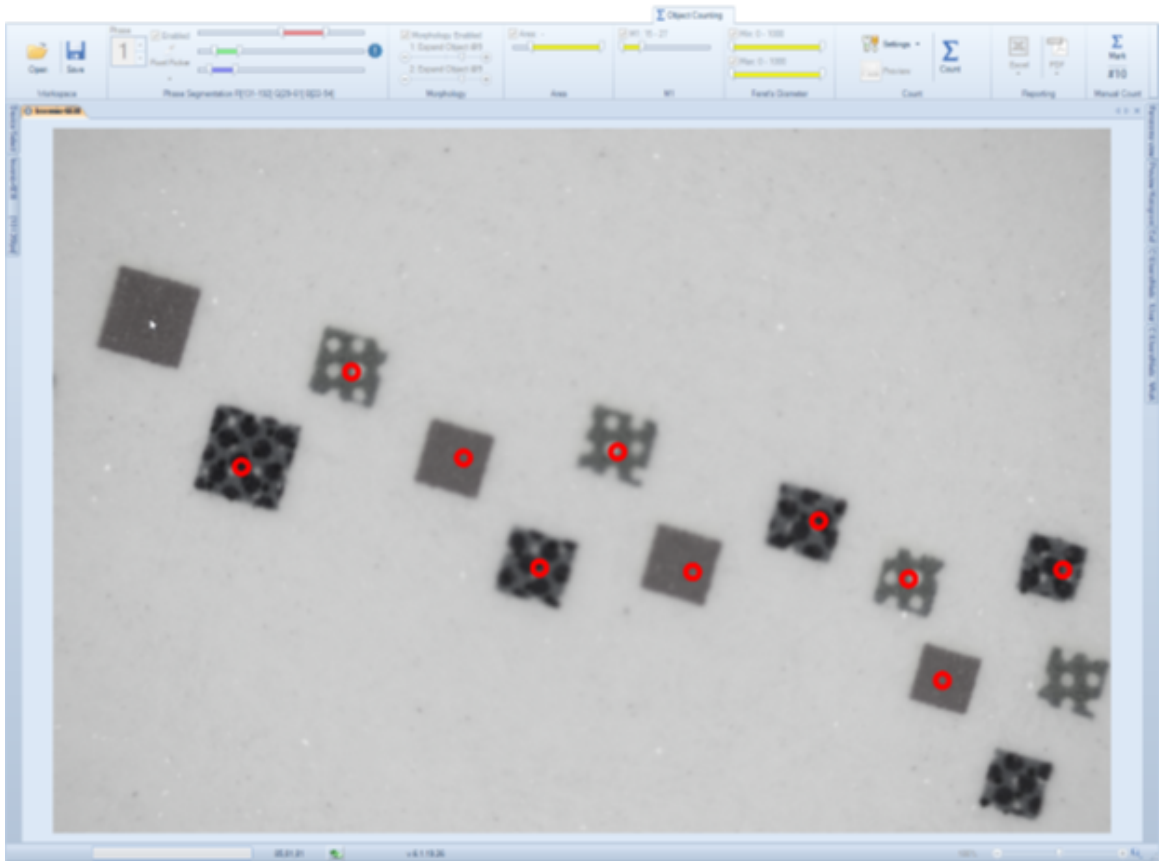

When the first counting point has been placed, the subsequent points can be created by hitting the space keyboard button. The count value is normally updated automatically.

## 15 The System Automation Tab

In this tab the XY and focus motor can be controlled. This is done by using the **arrow buttons**.

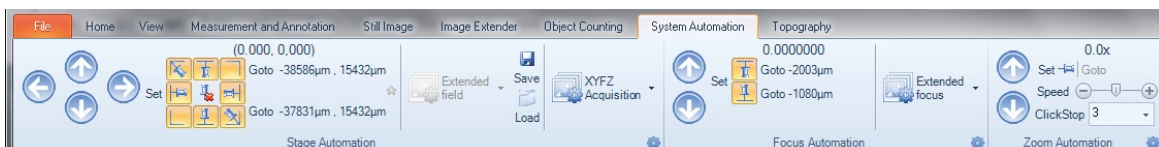

It is also possible to use the keyboard arrow keys for XY-stage control, and the PgUp and PgDn buttons for controlling the focus.

Click on the live preview image to enable this feature.

### 15.1 Stage Automation

The Stage Automation is used for controlling a motorized XY stage.

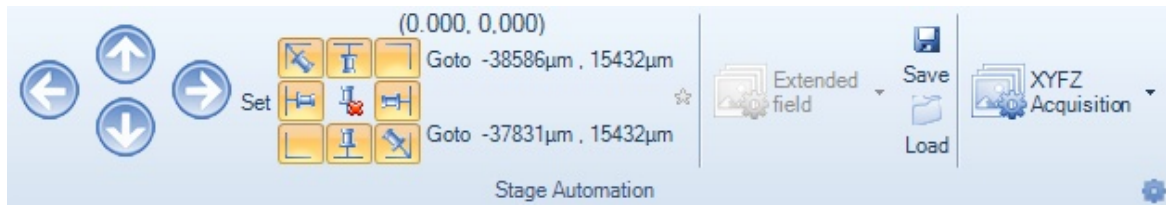

This can be used for the automated Extended Field tool or for capturing images at different positions at certain intervals.

### 15.1.1 Selecting and Configuring the Motor Controller

Click the small dialog launcher to configure the motor controller.

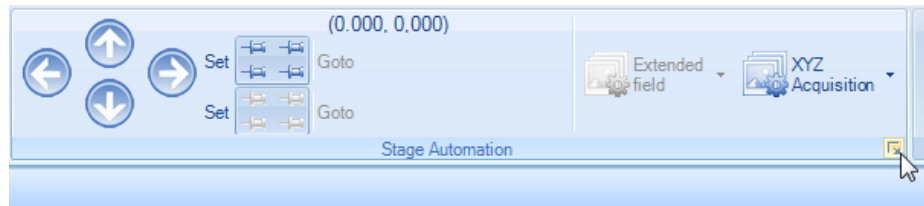

#### 15.1.1.1 Prior Controller

Prior controllers connect via a virtual COM port. Enter the COM port number and click 'Connect'.

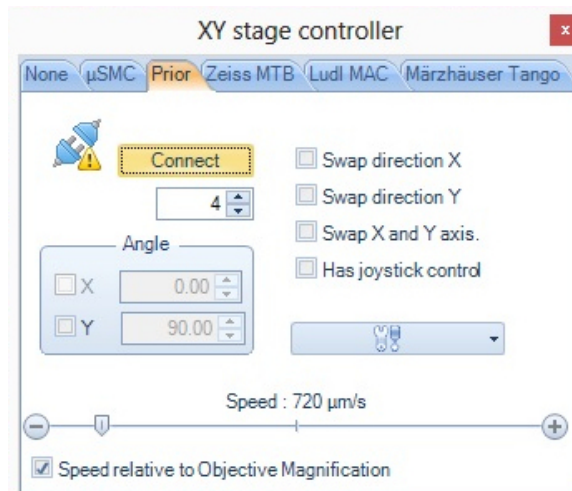

If connection succeeds, then just above the COM port, the type of the attached stage will be shown. In this example an ES111 stage is attached.

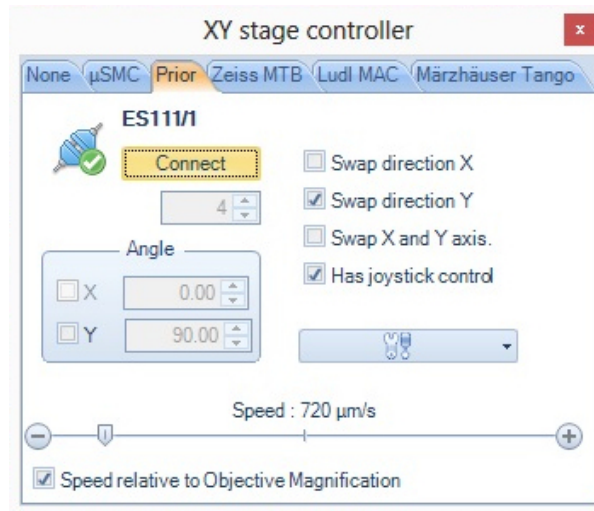

If the controller has joystick control, then automatic read back of position can be enabled by checking the 'Has joystick control' checkbox.

The **tools dropdown** shows the temperature and power supply of the controller. The Standby and Running currents can be set.

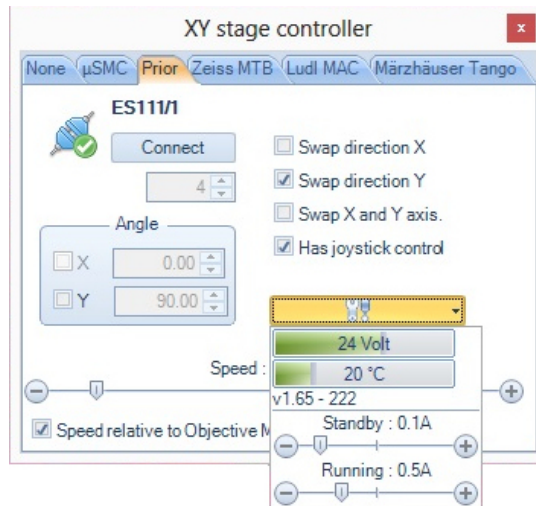

### 15.1.1.2 Zeiss MTB

Zeiss MTB

Chose the direction scheme that fits your physical setup.

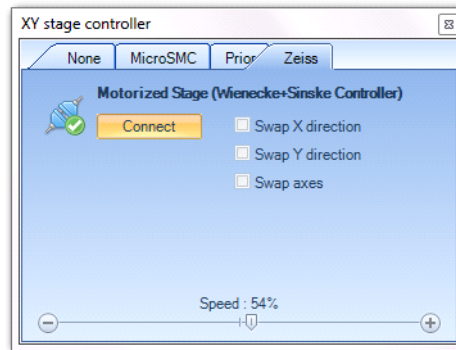

**NOTE:** Requires a well configured MTB2011 server. See [Installing and connecting to Zeiss MTB 2011](#)

### 15.1.1.3 Ludl MAC5000/MAC6000 Controller

Ludl MAC6000



Before connecting the controller, set the communication to the Ludl default settings.

Please note that other settings may be required depending on the controllers configuration, consult the controller documentation for more information on this.

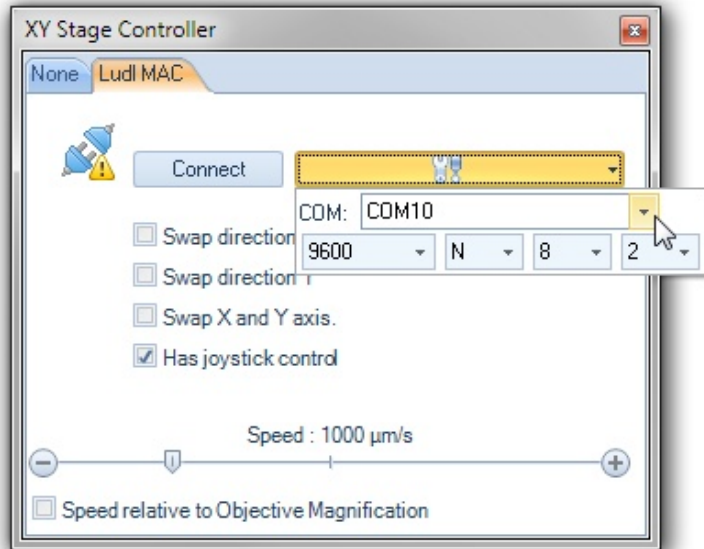

Connect to the controller.

When the controller has successfully connected the 'Connect' button will stay orange.

A text will show the name and version of the controller.

In addition a popup will show when hovering the connect button.

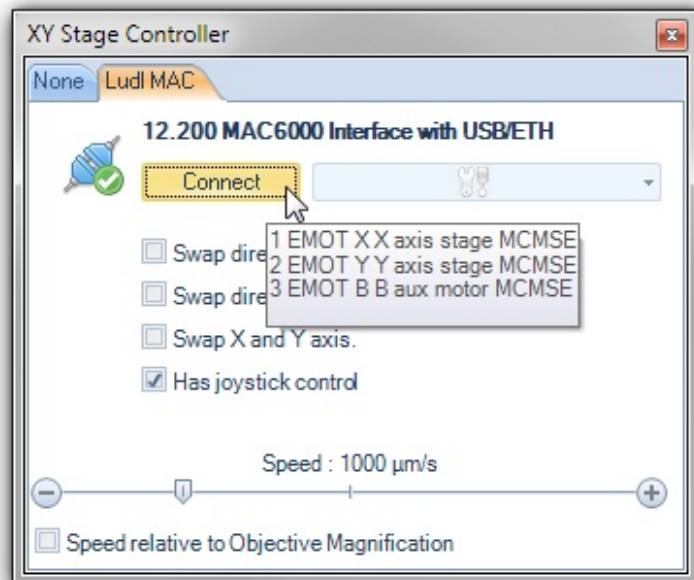



Chose the direction scheme that fits your physical setup.

If the controller has joystick control, then automatic read back of position can be enabled by checking the 'Has joystick control' check box.

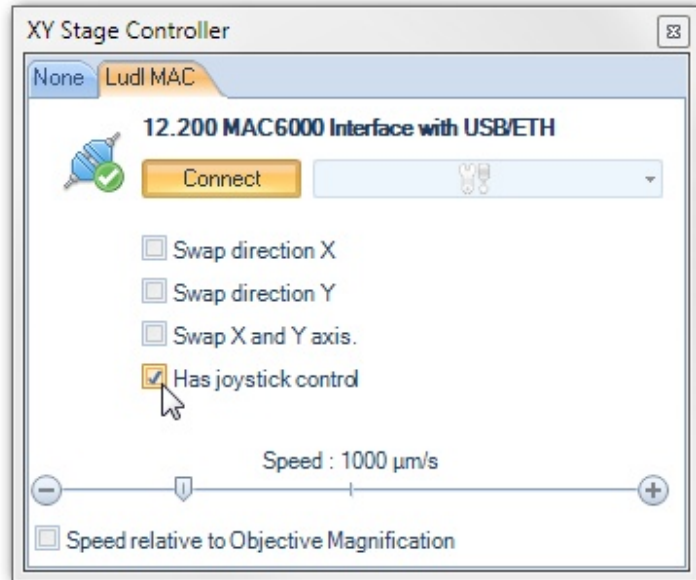

#### 15.1.1.4 Märzhäuser TANGO

Before connecting, the appropriate COM port must be selected. Normally the COM port will have friendly name "TANGO"

*STAGE XY  
EXAMPLE  
CONFIGURATION:  
XY-AXIS  
315 STEPS/  
MM, 200  
STEPS/REV  
MOTOR.*

*NOTE: FOR  
THE LIMIT  
SWITCH  
OPTION YOU  
MAY SELECT  
NONE, THEN  
THE DEFAULT  
OPTION (AS*

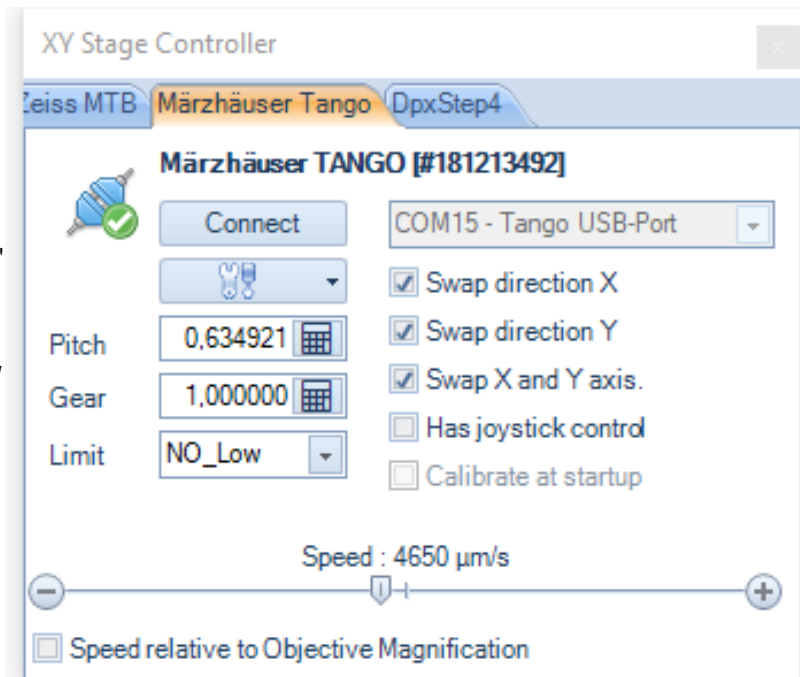



SEEN IN THE  
MÄRZHÄUSER  
SWITCHBOAR  
D) IS USED.

When  
connection is  
successfully  
established, the  
icon will  
change,  
and the serial  
number of the  
MÄRZHÄUSER  
TANGO will be  
shown in the  
top of the form.

After this, the  
DeltaPix InSight  
will  
automatically  
connect to  
the  
MÄRZHÄUSER  
TANGO when  
the program is  
started.

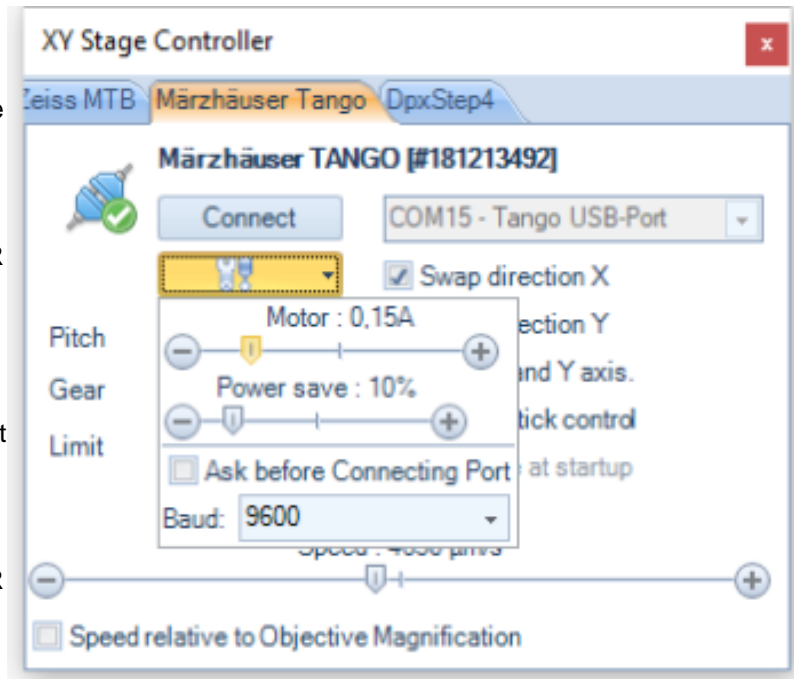

THE MOTOR  
POWER  
OPTION MUST  
BE  
CAREFULLY  
DEFINED TO  
MATCH THE  
MOTORS.

IF USING USB  
CONNECTION,  
THE BAUD  
RATE IS  
OBSOLETE.

### 15.1.1.5 DeltaStep4

The controller communicates via a virtual serial port. This is easily identified as a 'Silicon Labs CP210x' device.

If this is not already automatically selected, select it and click connect.

When successfully connected, a green check mark is shown.

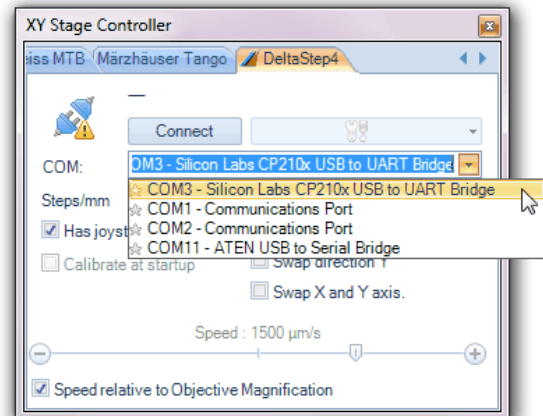

The **tools drop-down** shows the power supply of the controller. Both Running and standby current can be set.

The polarity of the limit switches can be set. To change the polarity check-box value, the shift key must be pressed while clicking – this is to prevent unintended change.

**Utmost care must be taken – selecting the wrong polarity may damage your motor device!**

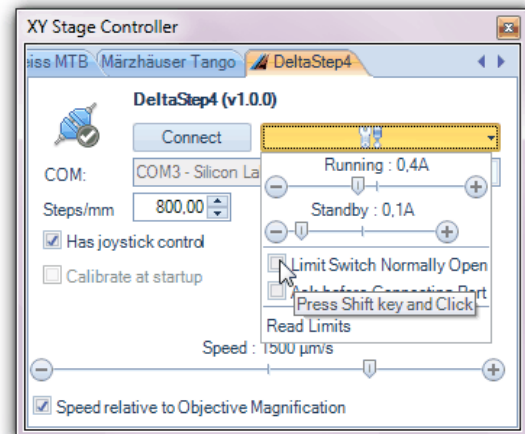

If the controller has joystick control, then automatic read back of position can be enabled by checking the 'Has joystick control' check-box.

### 15.1.1.6 Mitutoyo - MF

The controller communicates via a virtual serial port. This name of this may vary - in this example a CH340 USB-RS232 converter is used.

If this is not already automatically selected, select it and click connect.

When successfully connected, a green check mark is shown.

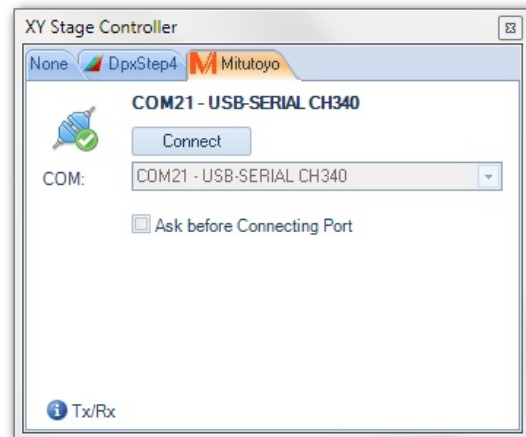

**PLEASE NOTE:** The Mitutoyo controller is **read-only**, so selecting this will only display the actual position.

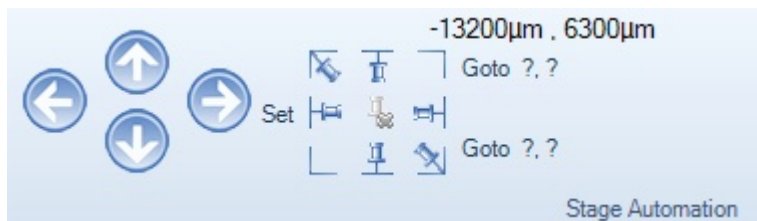

Manipulating the position can only be done directly on the microscope.

#### 15.1.1.6.1 Mitutoyo - Insert Scale Bar

Enter topic text here. By selecting the 'Insert Scale Barp' option, XY and focus position information will be added to the Scale Bar.

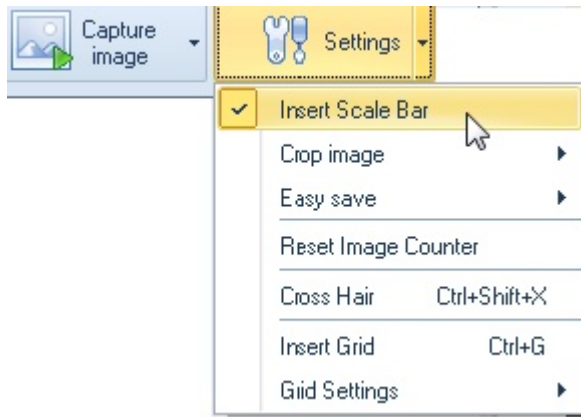

This will insert a scale bar into captured still images – including the XY and focus position.



#### 15.1.1.6.2 Mitutoyo - EXIF Information

The XY and focus position will also be written into the EXIF header of the image.

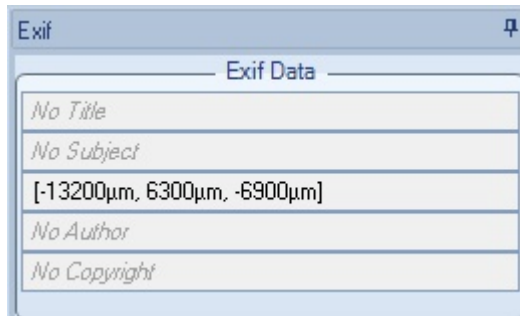

### 15.1.2 Making the motor speed relative to the Magnification

Most motor controllers can be configured to make their XY speed relative to the magnification. In practice this sets the speed lower if the magnification is set higher. As example a 20x magnification will run at 25% of the speed of a 5x magnification.

**The speed set in the XY controller panel will be used for the lowest magnification.**

### 15.1.3 Verifying the X and Y movement scheme

To make the automated scanning functions work, it is important that the movement scheme is correct. This is easily checked.

Sample with an object approximately in the middle of the preview image.

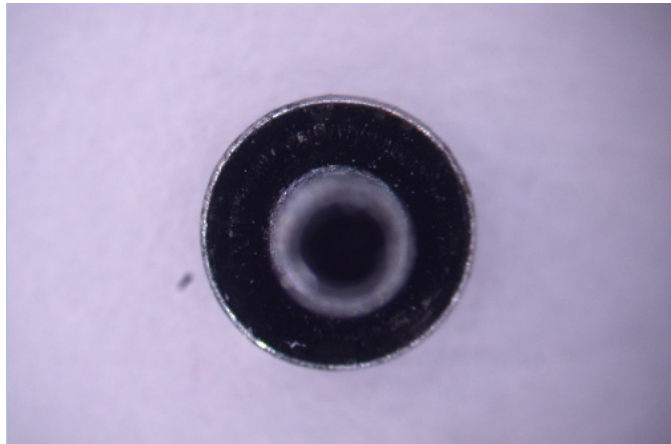

The 'Arrow Right' button must move the FOV to the right; this should make the object move to the left – as indicated in the image.

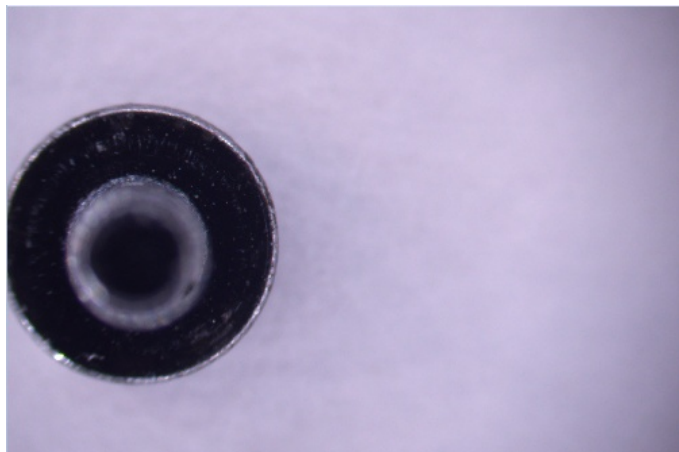

The 'Arrow Up' button must move the FOV upwards; this should make the object move down – as indicated in the image.

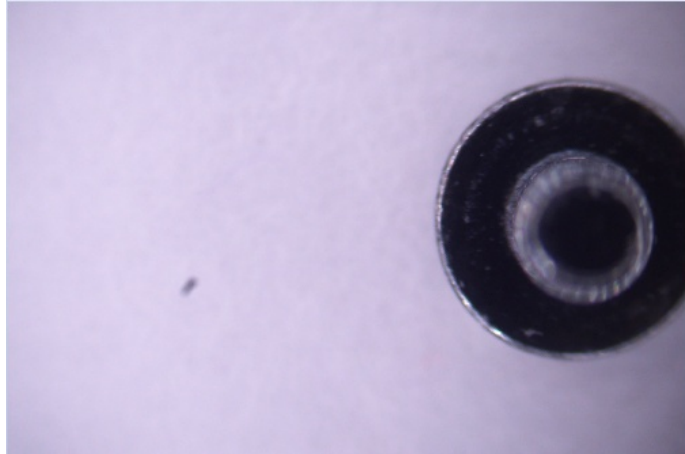

## 15.2 Automatic Extended Field

For automated Extended Field, move by the arrow buttons to the corners of the area-of-interest.



Select the region-of-interest, and click the pin...

The required number of images is automatically calculated – note that the camera and objective needs to be calibrated.

The 'Extended Field' button **Hint** will show the number of images to be acquired.

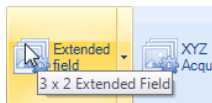

Click the **Extended field** button to start.





Using very many large size images may cause the process to run out of memory.

### 15.2.1 Automatic Extended Field with Extended Focus and Extended Exposure

The dropdown has checkboxes for including **Extended Exposure** and **Extended Focus**.



### 15.3 Automatic XYZ Acquisition

XYZ Acquisition can acquire images at predefined positions at regular intervals. This is useful for monitoring long term activity at different locations, e.g. in a Petri dish.

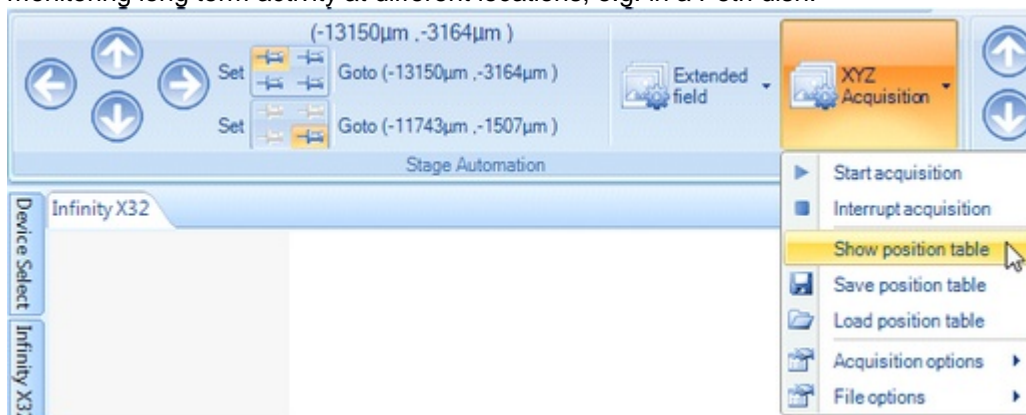

The XYZ positions for each image are stored in a table. The table can be saved and loaded.

To store the XYZ entries in the table click the **pin button**. Then by clicking the **arrow button** the XY-stage and Z-motor will move to the marked position.



Nbr	Set	Goto	Used	X	Y	Z	Comment
1			<input type="checkbox"/>	205,32	193,47	0	R=10
2			<input type="checkbox"/>				
3			<input checked="" type="checkbox"/>	105,32	93,47	0	R=0
4			<input checked="" type="checkbox"/>	105,32	93,47	0	{S}R0
5			<input checked="" type="checkbox"/>	80,75	97,41	0	R=1
6			<input checked="" type="checkbox"/>	80,75	97,41	0	{S}R1
7			<input checked="" type="checkbox"/>	141,29	95,27	0	R=2
8			<input checked="" type="checkbox"/>	141,29	95,27	0	{S}R2
9			<input checked="" type="checkbox"/>	45,48	135,59	0	R=3
10			<input checked="" type="checkbox"/>	45,48	135,59	0	{S}R3
11			<input checked="" type="checkbox"/>	158,4	128,88	0	R=4

Up to 500 positions can be stored.

### 15.3.1 Acquisition Options.

The **Acquisition options** define the acquisition period.

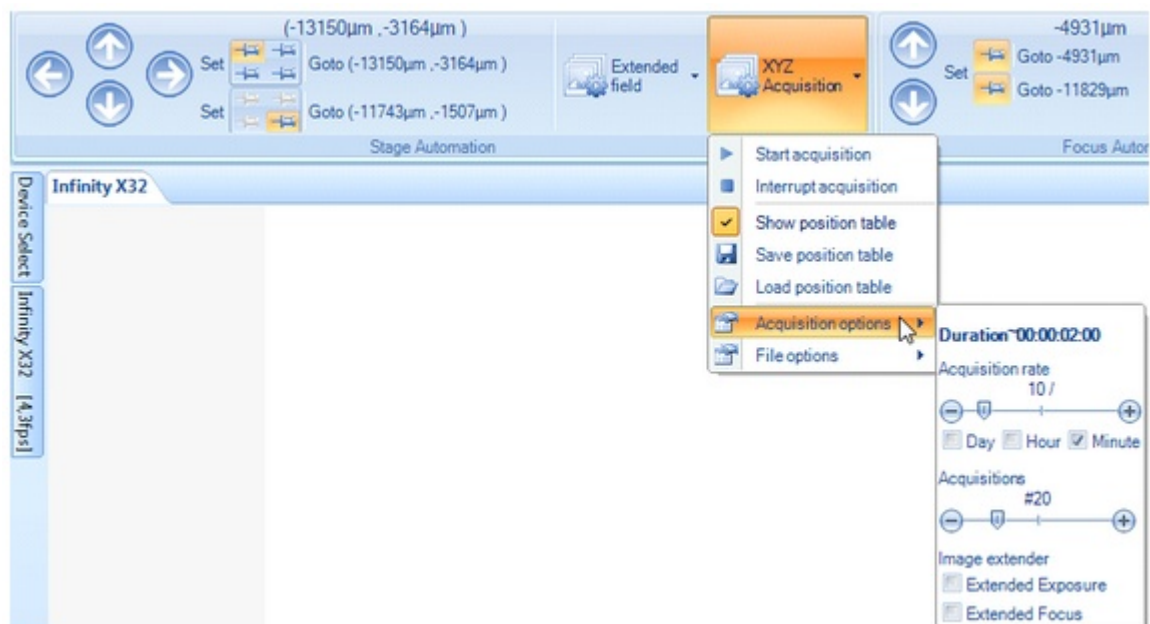

If e.g. the acquisition rate is set to 10 per minute and the number of acquisitions is set to 20, the total acquisition duration will then be  $20 \text{ [acquisitions]} / 10 \text{ [acquisitions/minute]} = 2 \text{ minutes}$ . In a period of 2 minutes 10 images will be acquired at each position.

When the acquisition has completed, the images can fairly easy be combined to a lapse time video. Use e.g. the ImageJ program from [www.nih.com](http://www.nih.com)

At each position the images can be acquired using **Extended Exposure** and **Extended Focus** tools.



### 15.3.2 Define the target image directory.

In the 'File options' click the floppy-button to define a target image directory to store the images.

Images can be saved in a variety of formats, 2D or 3D.

For the 2D.jpg, also select the image quality, it is recommended to click the rightmost star to have the best image quality.

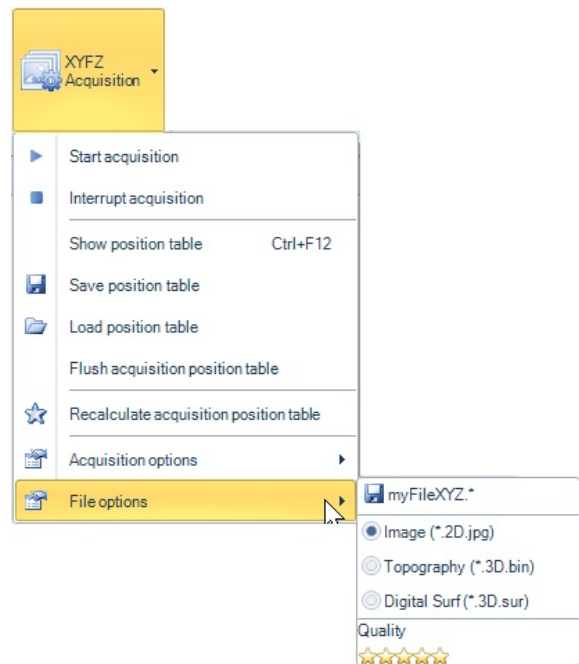

### 15.3.3 The position table.

Positions can be defined by moving the XY-stage to different positions, and then click the 'pin-button' for each position.

### 15.3.4 Defining Image Position macros in the 'Comment' field.

If images are to be acquired at fixed grid positions, a macro can be written in the Comment field. Move the stage to the reference position, and define the macro, then click the 'pin-button' associated with the reference point.

All the positions will the automatically be calculated.

Command	Usage
refxy	Make this point a reference point – position is ZigZag patten organized.
refxys	Make this point a reference point – position is Snake pattern organized. This is travel optimized to nearest next position, so focus should have minimum change.
n: sets nx and ny	
nx (default=1)	Sets number of columns (x direction). Example "nx=4"
ny (default=1)	Sets number of rows (y-direction). Example "ny=4"
d: sets dx and dy	
dx (default=1)	Distance between column starting position in microns (x direction).

	Example "dx=100"
dy (default=1)	Distance between row starting position in microns (y direction). Example "dy=100"
f-	Do not use focus position. The "f-" option is useful for surface focus tracking via the auto focus function. NOTE: Works for all positions after the position where it is defined, or until "f+".
f+	Use focus position. Used to switch off the "f-" option.
dt	Sets a delay in ms <u>after</u> stages have settled, and <u>before</u> image capture. Example "dt=1000". NOTE: Works for all positions after the position where it is defined. Disable by "dt=0"

In the comment field type the script.

Ex1: "refxy nx=10 dx=2000" sets 10x1 positions in a 2000x0 um grid

Ex2: "refxy nx=10 ny=3 dx=2000 dy=5000" sets 10x3 positions in a 2000x5000 um grid

Ex3: "refxy n=3 d=5000" sets 3x3 positions in a 5000x5000 um grid

Ex4: "refxy n=3 dx=1000 dy=2000" sets 3x3 positions in a 1000x2000 um grid

Ex5: "f- dt=1200" For this and the following positions do not use the focus position (maybe to rely solely on the autofocus tracking), and after XYFZ stage settles, wait ~1200ms before image acquisition.

Click the 'pin' button, all the positions will then be re-calculated with reference to the actual ref (x,y) position

**Example: refxy nx=5 ny=3 dx=2000 dy=5000**

Nbr	Set	Goto	Used	X	Y	Focus	Zoom	Macro
1			<input checked="" type="checkbox"/>	-16782	-14279	2		efxy nx=5 ny=3 dx=2000 dy=5000
2			<input checked="" type="checkbox"/>	-14782	-14279	2	0	{A}
3			<input checked="" type="checkbox"/>	-12782	-14279	2	0	{A}
4			<input checked="" type="checkbox"/>	-10782	-14279	2	0	{A}
5			<input checked="" type="checkbox"/>	-8782	-14279	2	0	{A}
6			<input checked="" type="checkbox"/>	-16782	-9279	2	0	{A}
7			<input checked="" type="checkbox"/>	-14782	-9279	2	0	{A}
8			<input checked="" type="checkbox"/>	-12782	-9279	2	0	{A}
9			<input checked="" type="checkbox"/>	-10782	-9279	2	0	{A}
10			<input checked="" type="checkbox"/>	-8782	-9279	2	0	{A}
11			<input checked="" type="checkbox"/>	-16782	-4279	2	0	{A}
12			<input checked="" type="checkbox"/>	-14782	-4279	2	0	{A}
13			<input checked="" type="checkbox"/>	-12782	-4279	2	0	{A}
14			<input checked="" type="checkbox"/>	-10782	-4279	2	0	{A}
15			<input checked="" type="checkbox"/>	-8782	-4279	2	0	{A}
16			<input type="checkbox"/>				0	
17			<input type="checkbox"/>				0	

A simple example of 15 images to be acquired at a distance of 2000um in the x-direction and 2000um in the y-direction.

The {A} and the bluish color indicates that this is a macro calculated point.

### 15.3.5 Defining Point Transformation macros in the 'Comment' field.

Command	Usage
P=0	R0 - Coordinate origin
P=10	R10 - is the same point as R0, but used for shift compensation and accumulated stage error.
R=1	R1 – Reference point on the left side corresponding to R2 on the right
R=2	R2 - Reference point on the right side corresponding to R1 on the left
R=3	R3 - Reference point on the left side corresponding to R4 on the right
R=4	R4 - Reference point on the left side corresponding to R3 on the left
G=5	G5 – A data point on the left side. A corresponding G6 point will be calculated. Several G5 points can be defined.

G=6

G6 - A data point on the right side. A corresponding G5 point will be calculated. Several G6 points can be defined.

The drawing below explains the principles:

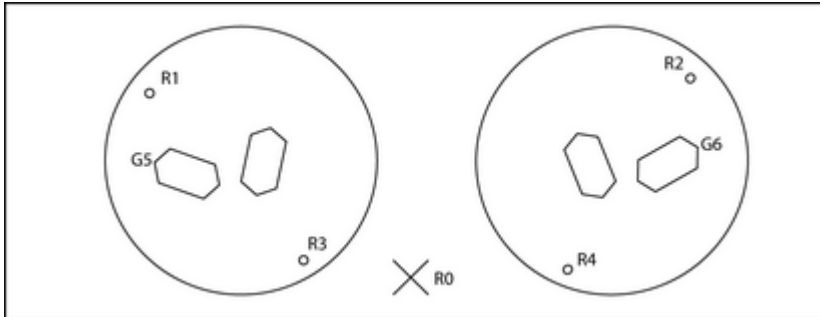

Drawing courtesy of Maria Giuditta Fellin, ETH Zurich

This table show the principle of the coordinate transformation macros.

XYZ Acquisition							
Save table Open table Recalculate table Flush table							
Nbr	Set	Goto	Used	X	Y	Z	Comment
1			<input checked="" type="checkbox"/>	205.32	193.47	0	Coordinate Origo Correction (R=10)
2			<input type="checkbox"/>				
3			<input checked="" type="checkbox"/>	105.32	93.47	0	Coordinate OrigoOrigo (R=0)
4			<input checked="" type="checkbox"/>	205.32	193.47	0	(S)R0
5			<input checked="" type="checkbox"/>	80.75	97.41	0	Reference point #1 on the Left side (R=1)
6			<input checked="" type="checkbox"/>	180.75	197.41	0	(S)R1
7			<input checked="" type="checkbox"/>	141.29	95.27	0	Reference point #1 on the Right side (R=2)
8			<input checked="" type="checkbox"/>	241.29	195.27	0	(S)R2
9			<input checked="" type="checkbox"/>	45.48	135.59	0	Reference point #2 on the Left side (R=3)
10			<input checked="" type="checkbox"/>	145.48	235.59	0	(S)R3
11			<input checked="" type="checkbox"/>	169.4	138.99	0	Reference point #2 on the Right side (R=4)
12			<input checked="" type="checkbox"/>	269.4	238.99	0	(S)R4
13			<input type="checkbox"/>				
14			<input checked="" type="checkbox"/>	46.6	119.76	0	A data point on the Left side (G=5)
15			<input checked="" type="checkbox"/>	146.6	219.76	0	(S)G5
16			<input checked="" type="checkbox"/>	271.0441	223.2062	0	(T)G6
17			<input type="checkbox"/>				
18			<input checked="" type="checkbox"/>	171.04	123.21	0	A data point on the Right side (G=6)
19			<input checked="" type="checkbox"/>	271.04	223.21	0	(S)G6
20			<input checked="" type="checkbox"/>	146.6033	219.7645	0	(T)G5

For more information on this topic, please contact [support@deltapix.dk](mailto:support@deltapix.dk)

### 15.3.6 Table Macro programming

#### Table Macro programming

The position table can easily be modified manually. The smarter way is to do it automated by writing a specialized macro. Advanced operations and transformations can be performed.

The macro language is C# - and writing a macro requires some programming skills.

Open the macro editor.

The button name 'MyCaption' can change programmatically in the macro to a more intuitive name.

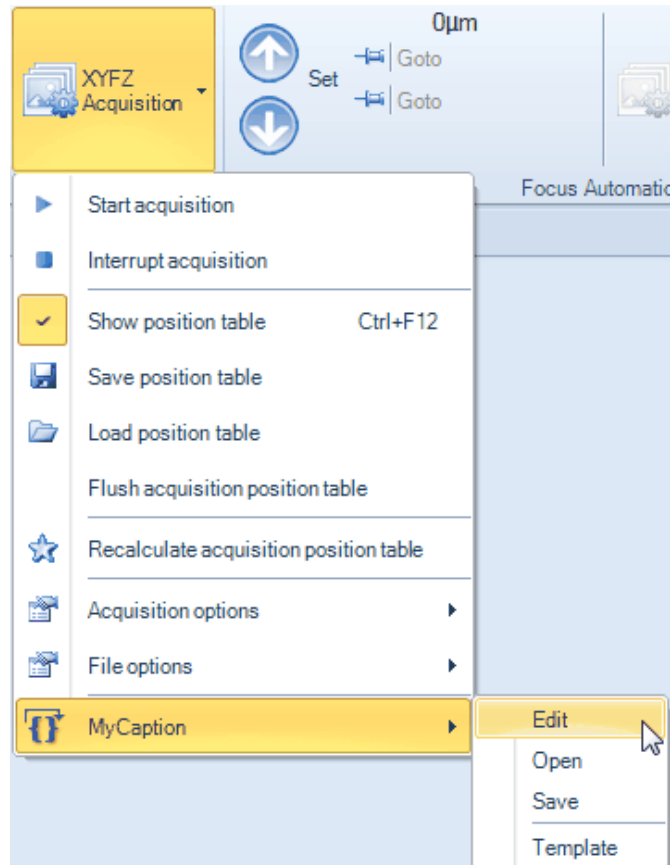

Please contact [support@deltapix.dk](mailto:support@deltapix.dk) for help with your specific macro programming – if necessary.

Click the 'Edit' button to enter edit mode. The text window will turn yellowish.

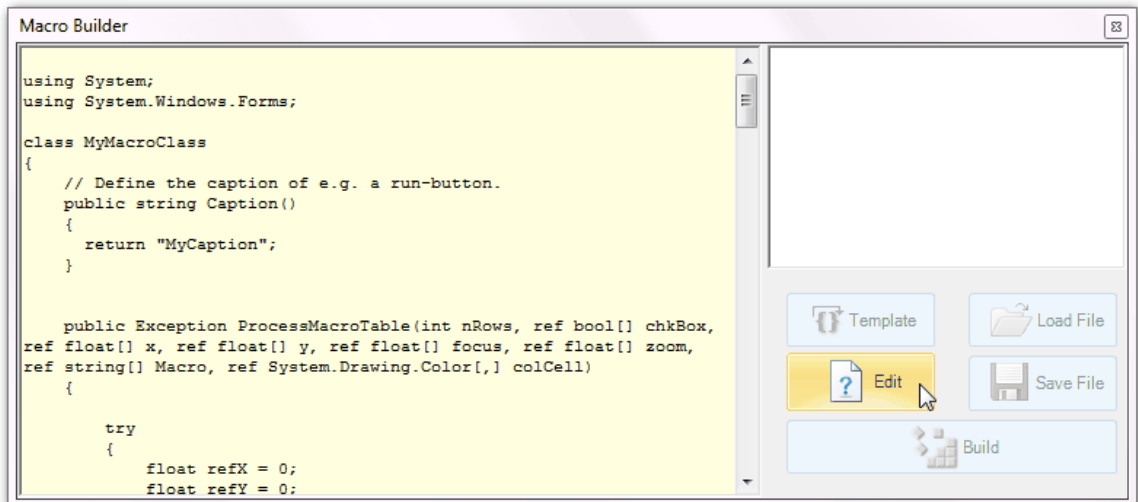

As example we change the Caption function – this will change the macro button name.

Click 'Build' – and hopefully the build is successfully.

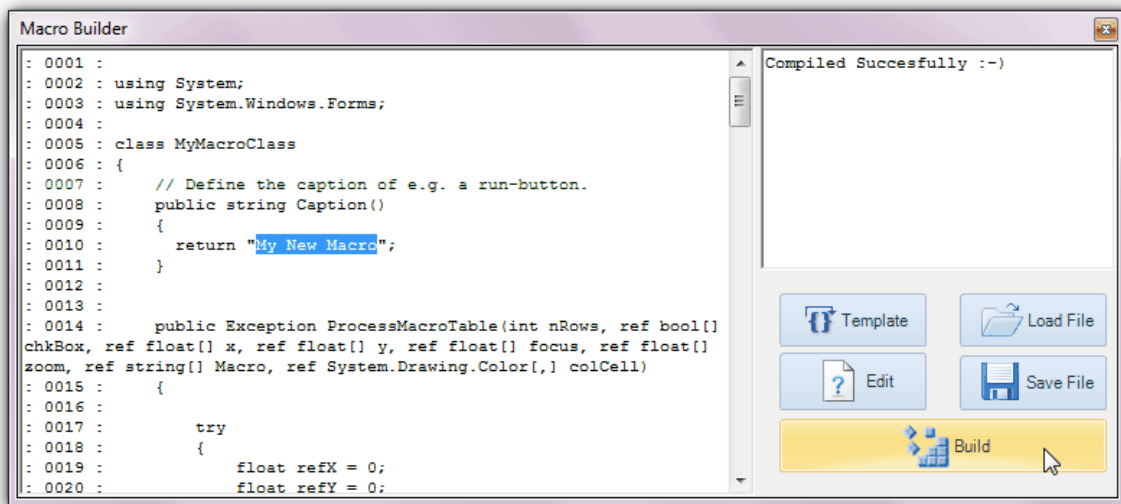

The button name will reflect the macro change.

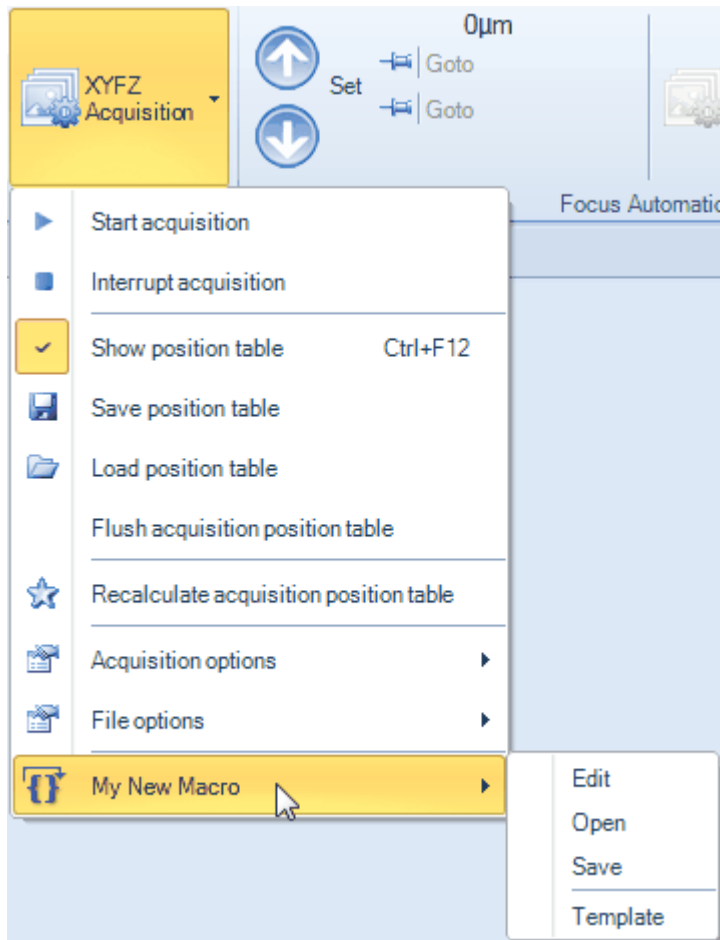

### Macro error

In case of a syntax error, the line number and some text is displayed in the upper right window. In this example there is a trailing 'm' character problem in line 10.



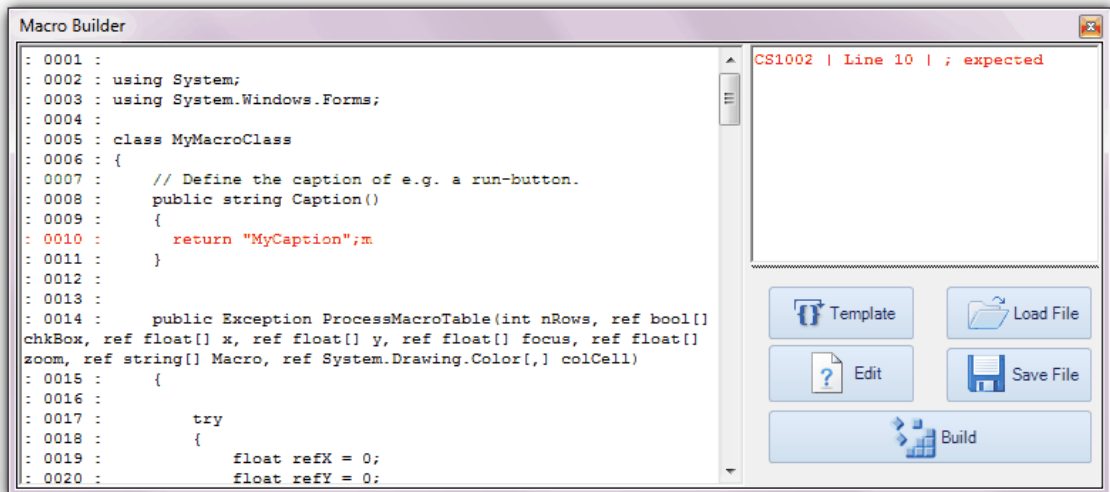

### 15.3.6.1 Table Macro Programming - Example code

```

public Exception ProcessMacroTable(int nRows, ref bool[] chkBox, ref float[] x, ref
float[] y, ref float[] focus, ref float[] zoom, ref string[] Macro, ref
System.Drawing.Color[,] colCell)
{
    try
    {
        float refX = 0;
        float refY = 0;
        float refFocus = 0;
        float refZoom = 0;

        for (int r = 0; r < nRows; r++)
        {
            if (null != Macro[r])
            {
                // Parse and color code Macro-field
                string cmt = Macro[r];
                System.Drawing.Color colMacro = System.Drawing.Color.White;

                if (cmt.Contains("Hello") == true)
                {
                    colMacro = System.Drawing.Color.Yellow;
                    chkBox[r] = true;
                }

                if (cmt.Contains("Goodbye") == true)
                {
                    colMacro = System.Drawing.Color.Pink;
                    chkBox[r] = false;
                }

                // Specify a test macro M0 - store data
                if (cmt.Contains("M0") == true)
                {
                    Macro[r] = "M0 REF";
                    refX = x[r];
                    refY = y[r];
                    refFocus = focus[r];
                    refZoom = zoom[r];
                }
            }
        }
    }
}

```

```

// Specify a test macro M1
if (cmt.Contains("M1") == true)
{
    colMacro = System.Drawing.Color.Lime;
    Macro[r] = "M1 ADD";
    x[r] = x[r - 1] + refX;
    y[r] = y[r - 1] + refY;
    focus[r] = focus[r - 1] + refFocus;
}

// Specify a test macro M2
if (cmt.Contains("M2") == true)
{
    colMacro = System.Drawing.Color.Cyan;
    Macro[r] = "M2 MUL";
    x[r] = 2 * x[r - 1];
    y[r] = 3 * y[r - 1];
    focus[r] = 4 * focus[r - 1];
}

colCell[r, 3] = colMacro;

// Color code X-fields
colCell[r, 0] = (x[r] > 10) ? System.Drawing.Color.SpringGreen :
System.Drawing.Color.PaleGreen;

// Color code Y-fields
colCell[r, 1] = (y[r] > 10) ? System.Drawing.Color.SpringGreen :
System.Drawing.Color.PaleGreen;

// Color code Z-fields
colCell[r, 2] = (focus[r] > 10) ? System.Drawing.Color.SpringGreen :
System.Drawing.Color.PaleGreen;

}

}
}
catch (Exception ex)
{
    return ex;
}

return new Exception(null, null);
}
}

```

## 15.4 Focus automation

The Focus Automation is used for controlling a motorized Focus stage.

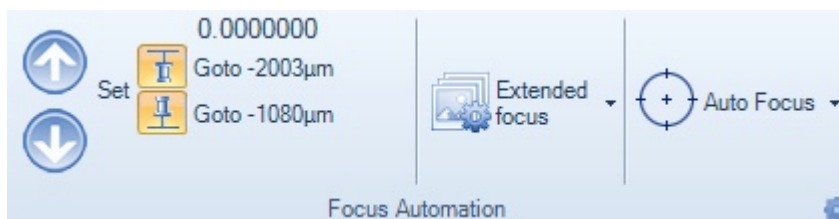

This allows for automated Extended Focus, Automated Topography and Auto Focus.

### 15.4.1 Selecting and Configuring the Motor Controller

The **Focus automation** is used for controlling a motorized Z stage. This can be used for automated Extended Focus.

Click the small dialog launcher to configure the motor controller.

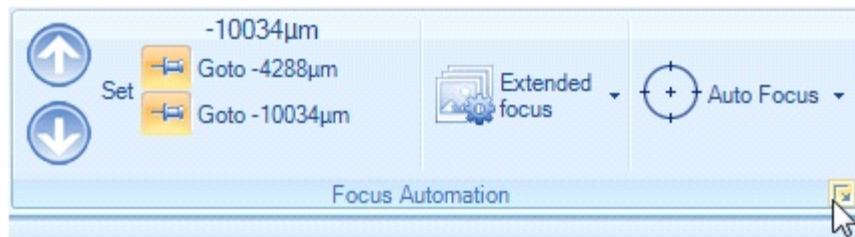

#### 15.4.1.1 Prior Controller

Prior controllers connect via a virtual COM port. Enter the COM port number and click 'Connect'.

Note that this controller is not yet connected – see the 'plug icon'.

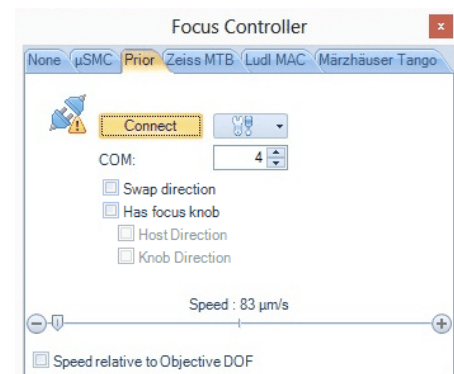

If connection succeeds, the plug icon changes status to connected plugs.

Check the 'Has focus knob' for automatic read back of position.

The movement direction determined by the up/down buttons can be reversed by checking the 'Host Direction' check box.

The movement direction determined by the focus knob can be reversed by checking the 'Knob Direction' check box.

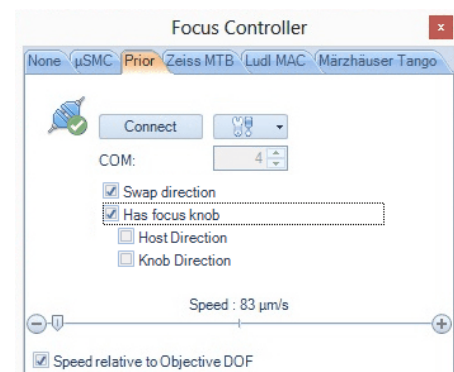

The tools drop down shows the temperature and power supply of the controller.

The Standby and Running currents can be set.

In case of custom focus motor, the Steps/mm parameter can also be set to ensure correct Z scaling.

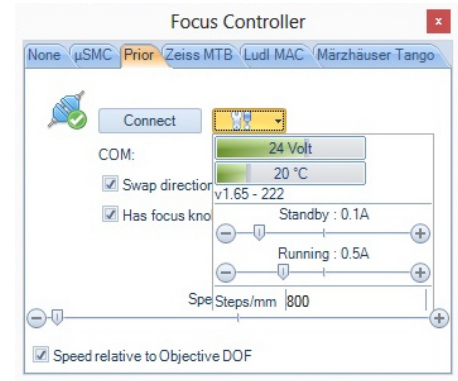

See appendix 1 for configuring Prior OptiScanII controller.

#### 15.4.1.2 Zeiss MTB

**When connection succeeds, the plug icon changes status to connected plugs.**

Check the **Encoded objectives** for automatic read back of selected objective, note that this also impacts the calibration requirements.

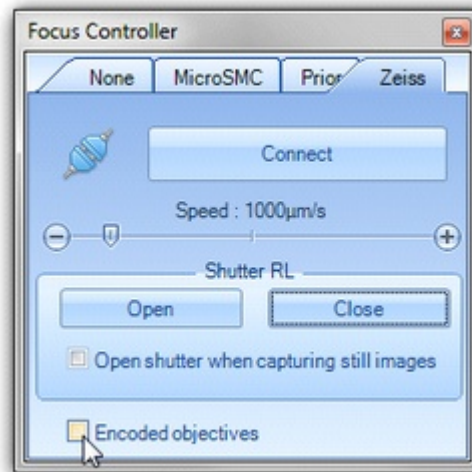

*Note: Prior controllers can also connect via the Zeiss MTB server.*

**NOTE:** Requires a well configured MTB2011 server. See [Installing and connecting to Zeiss MTB 2011](#)

### 15.4.1.3 Ludl MAC5000/MAC6000 Controller

Ludl MAC6000



Before connecting the controller, set the communication to the Ludl default settings.

Please note that other settings may be required depending on the controllers configuration, consult the controller documentation for more information on this.

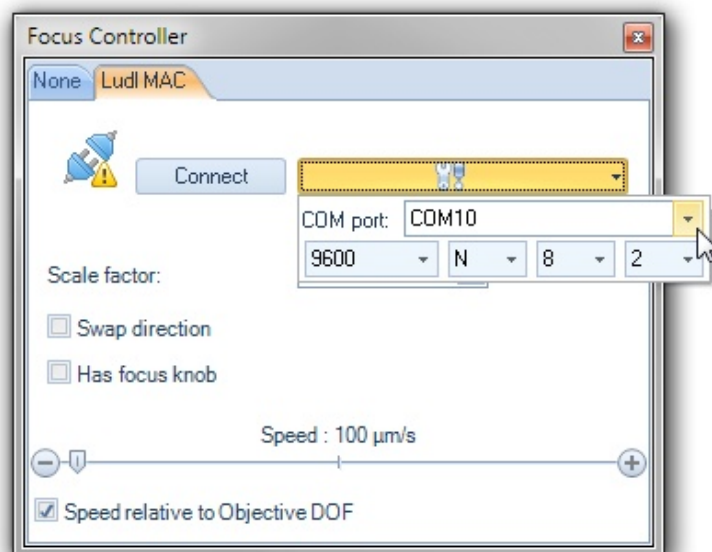

Connect to the controller.

When the controller has successfully connected the 'Connect' button will stay orange.

A text will show the name and version of the controller.

In addition a popup will show when hovering the connect button.

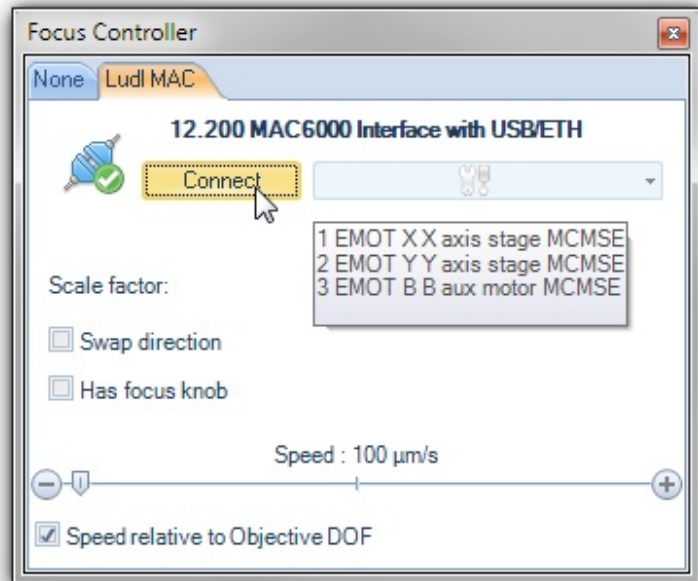

Chose the direction scheme that fits your physical setup.

If the controller has a fine focus knob control, then automatic read back of position can be enabled by checking the 'Has focus knob' check box.

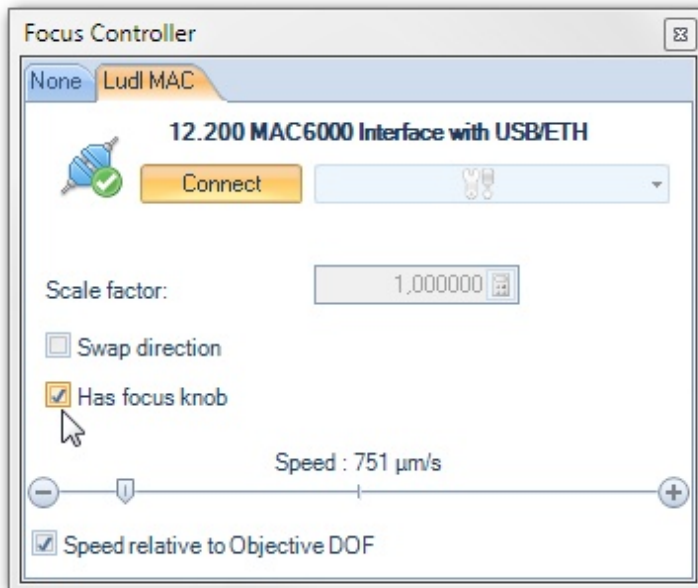

If an absolute encoder is not used, it may be necessary to scale the position read from the controller.

This is done via the optional scale factor.

**NOTE: The controller must be disconnected in order to modify the scale factor.**

Default value is 1.00

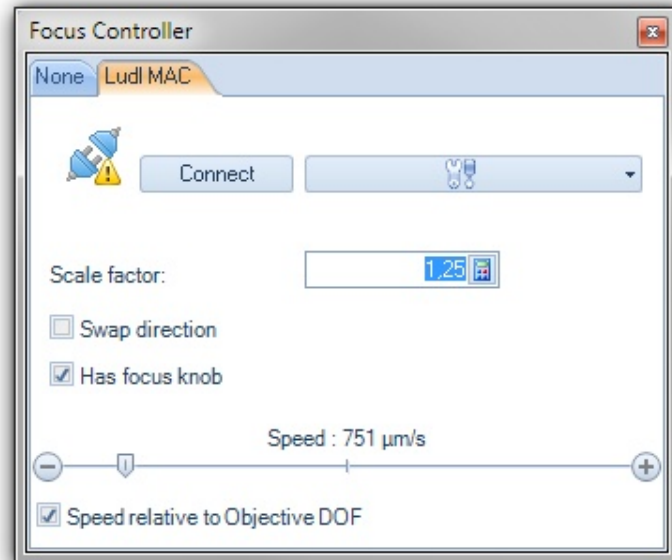

The scale factor can also be entered via the calculator drop down menu.

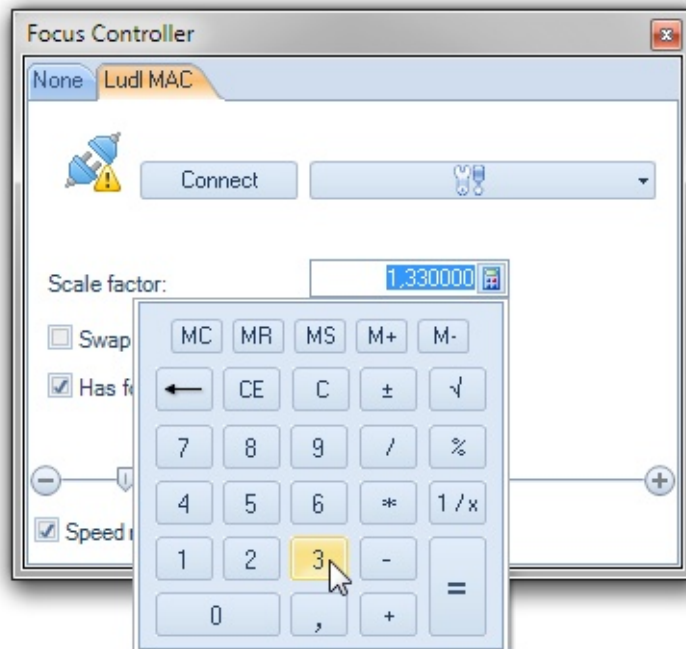

#### 15.4.1.4 Märzhäuser TANGO

Before connecting, the appropriate COM port must be selected.

*STAGE FOCUS EXAMPLE CONFIGURATION: Z-AXIS 800 STEPS/MM, 200 STEPS/REV MOTOR.*

*NOTE: FOR THE LIMIT SWITCH OPTION YOU MAY SELECT NONE, THEN THE DEFAULT OPTION (AS SEEN IN THE MÄRZHÄUSER SWITCHBOARD) IS USED.*

When connection is successfully established, the icon will change, and the serial number of the MÄRZHÄUSER TANGO will be shown in the top of the form. After this, the DeltaPix InSight will automatically connect to the MÄRZHÄUSER TANGO when the program is started.

*THE MOTOR POWER OPTION MUST BE CAREFULLY DEFINED TO MATCH THE MOTORS.*

*IF USING USB CONNECTION, THE BAUD RATE IS OBSOLETE.*

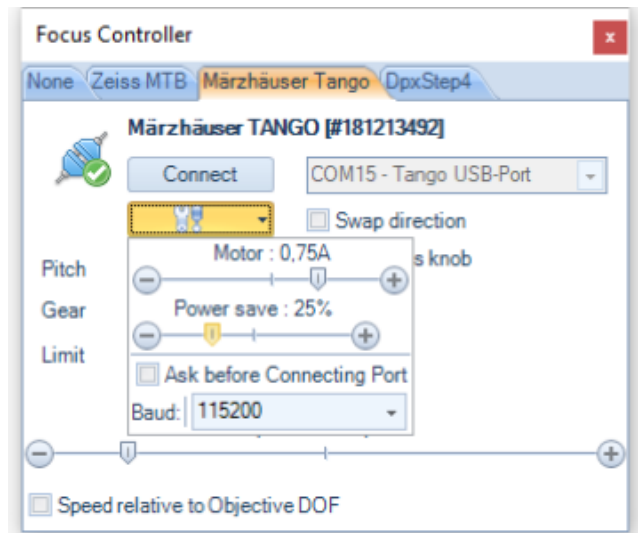
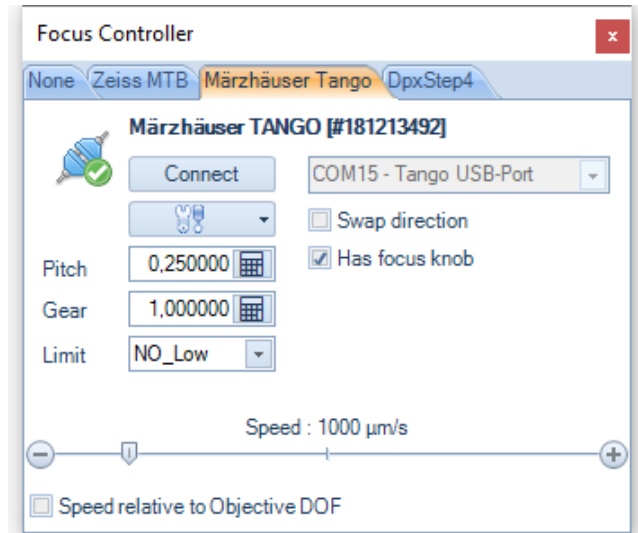



### 15.4.1.5 DeltaStep4

The controller communicates via a virtual serial port. This is easily identified as a 'Silicon Labs CP210x' device.

If this is not already automatically selected, select it and click connect.

When successfully connected, a green check mark is shown.

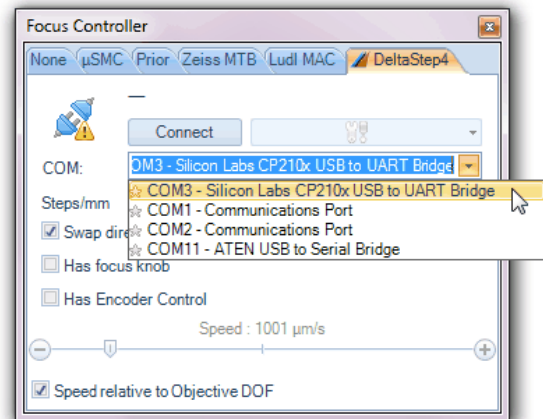

The **tools drop-down** shows the power supply of the controller. Both Running and standby current can be set.

The polarity of the limit switches can be set. To change the polarity check-box value, the shift key must be pressed while clicking – this is to prevent unintended change.

**Utmost care must be taken – selecting the wrong polarity may damage your motor device!**

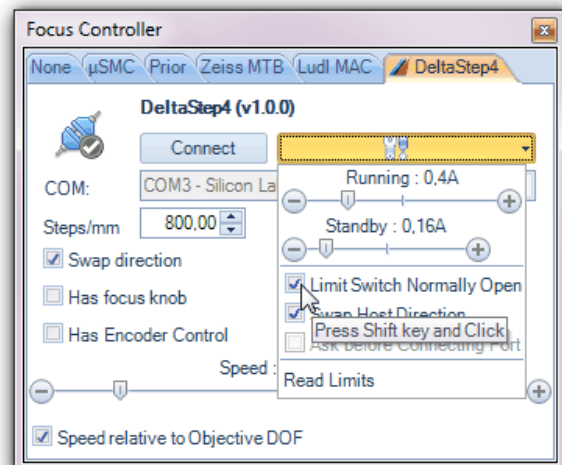

If the controller has focus knob control, then automatic read back of position can be enabled by checking the 'Has focus knob' checkbox.

If the controller has a built-in encoder wheel, check the 'Has Encoder Control'. Otherwise leave unchecked.

### 15.4.1.6 Mitutoyo - MF

The controller communicates via a virtual serial port. This name of this may vary - in this example a CH340 USB-RS232 converter is used.

If this is not already automatically selected, select it and click connect.

When successfully connected, a green check mark is shown.

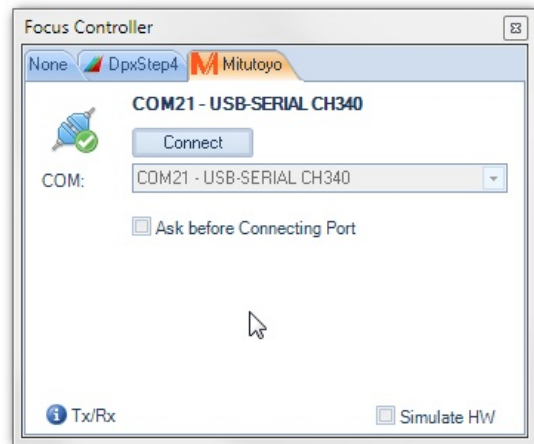

**PLEASE NOTE:** The Mitutoyo controller is **read-only**, so selecting this will only display the actual position.

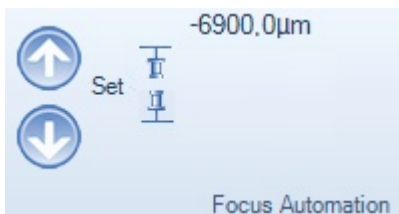

Manipulating the position can only be done directly on the microscope.

#### 15.4.1.6.1 Mitutoyo - Insert Scale Bar

By selecting the 'Insert Scale Barp' option, XY and focus position information will be added to the Scale Bar.

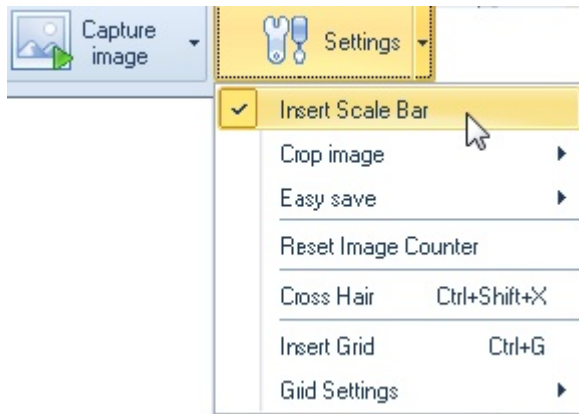

This will insert a scale bar into captured still images – including the XY and focus position.



#### 15.4.1.6.2 Mitutoyo - EXIF Information

The XY and focus position will also be written into the EXIF header of the image.

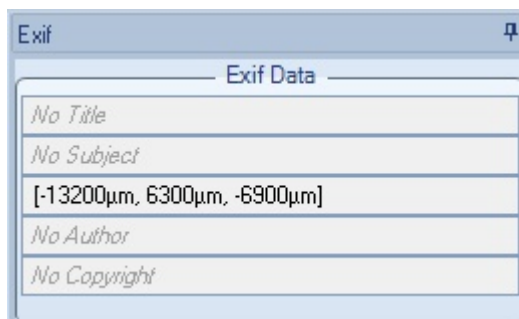

## 15.4.1.7 ErgoFocus

**NOTE: ErgoFocus will only work on Windows 10/11. Windows 7 or 8 will not install correct drivers!**

The ErgoFocus controller communicates via a USB port (virtual serial port).

This is automatically identified (from the unique VID/PID).

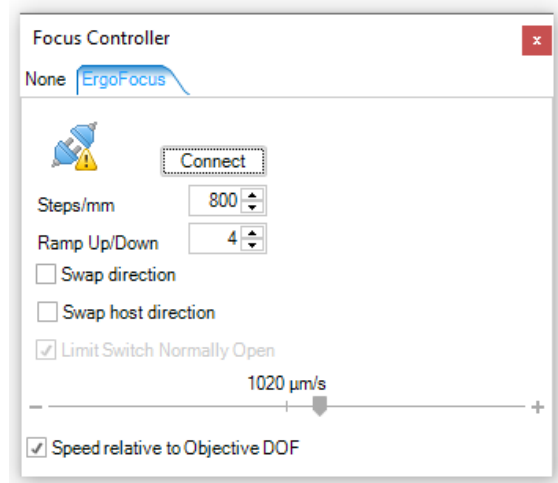

When successfully connected, a green check mark is shown.

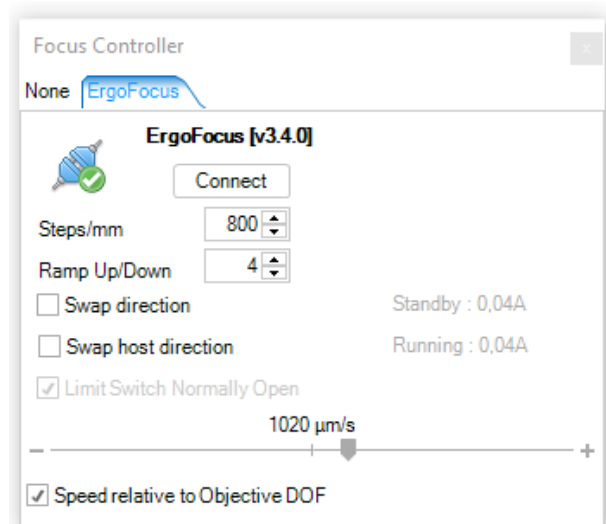

### **Steps/mm**

The Steps/mm parameter must be set to correct Z scaling.  
It is calculated as:  $\text{motor}[\text{steps/rev}] / \text{Spindle}[\text{mm/rev}]$ .

Example: Stepper motor has 200[steps/rev], and spindle pitch is 0.25[mm/rev], this makes the Steps/mm parameter =  $200 / 0.25 = 800$ .

**Ramp Up/Down**

This sets the start/stop acceleration ramp.

The bigger number, the slower acceleration. A value of 0 means 'instant' start/stop.

**Swap Direction**

Reverses the motor direction

**Swap host direction**

Reverses the sign of the position readout

**Limit switch Normally Open**

The polarity of the limit switches can be set. The default is "Normally Open".

**Standby- and Running current**

For ErgoFocus firmware  $\geq$  v3.1.3 there is an option to adjust the standby- and running-current.

Adjusting the current requires great care and diligence.

DeltaPix can provide instructions on how to do this. Please contact support@deltapix.dk.

## 15.4.1.7.1 Stand alone mode - parameters

Requires ErgoFocus firmware 1.4 or higher.

For standalone the parameters must be set using DeltaPix InSight.

DeltaPix InSight.

Connect to the ErgoFocus controller, and set parameters as needed.

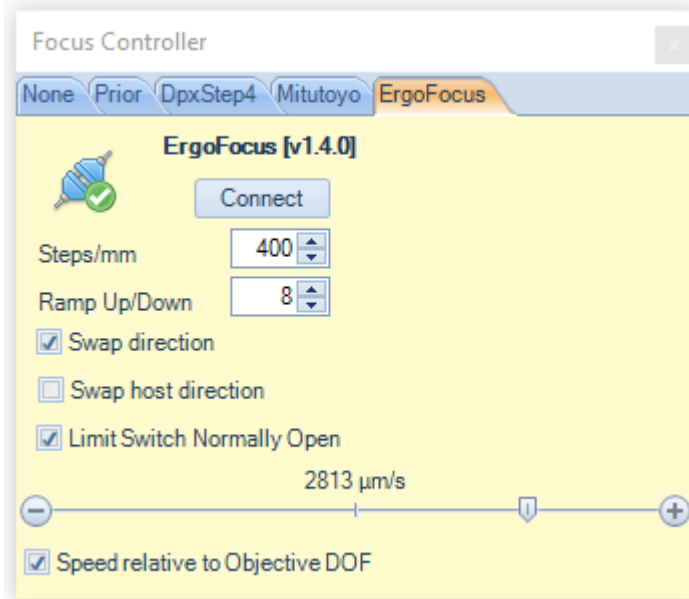

DeltaPix ErgoFocus:

Press joystick button (~5secs) to see/check the non-volatile parameters

```
Steps/mm[400] Ramp[8]
[V] SwapDir
[ ] SwapHostDir
[V] Lim NO
```

[V] = Checked

#### 15.4.1.7.2 ErgoFocus firmware versions

ErgoFocus firmware is developed by DeltaPix.

To make it work with DeltaPix InSight some version matching must be observed.

- ErgoFocus firmware version < v3.3.3 works with all DeltaPix InSight versions  $\geq$  v6.1.10
- ErgoFocus firmware version  $\geq$  v3.3.3 works with all DeltaPix InSight versions  $\geq$  v6.7.0

#### 15.4.1.8 Camera with integrated focus control

Some cameras like eg. the H4KWSD08DPX has integrated back focus motor.

This can be selected as focus motor controller.

Different modes focus modes can be selected.

The manual focus should be selected to use the integrated focus automation for creating extended focus images.

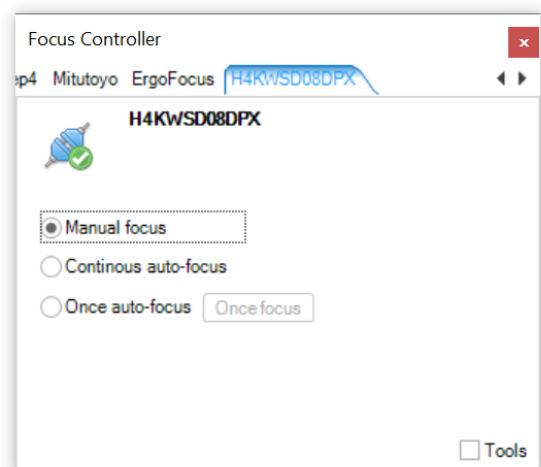

#### 15.4.2 Automatic Extended Focus

Use the arrow buttons to the upper and lower focus positions, and mark each position by pressing the **pin buttons**.

When top and bottom Z-positions have been defined, click the **Extended Focus** button to start the automatic Extended Focus.

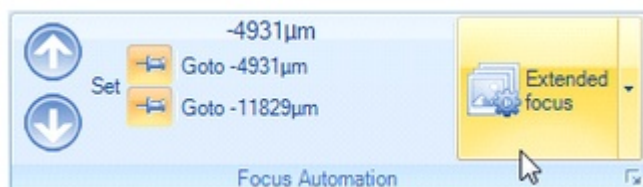



The best result is achieved using telecentric objectives. Non-telecentric objectives and stereo microscopes may require an increase of the default parameters in the **Extended Focus Settings dropdown**.

#### 15.4.2.1 Setting the Number of Z-slices to be acquired.

The number of images is defined in the 'Image Extender tab. In the **Extended Focus Settings dropdown** set the number of slices.

This is shown here.

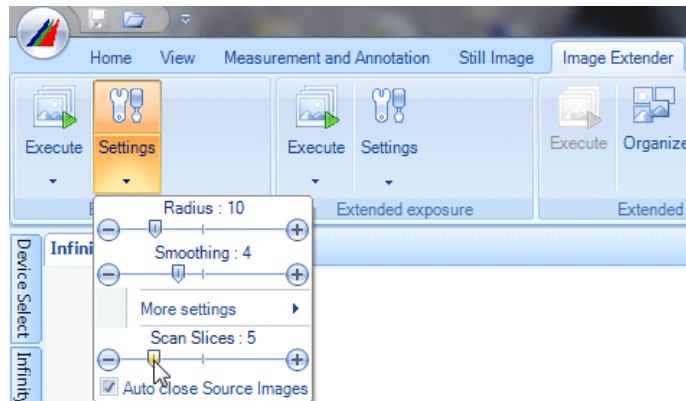

Using many large size images may cause the process to run out of memory.

#### 15.4.2.2 Using the DOF from the Optics Editor

If a DOF for the objective has been defined, then the number of required slices can be automatically calculated.

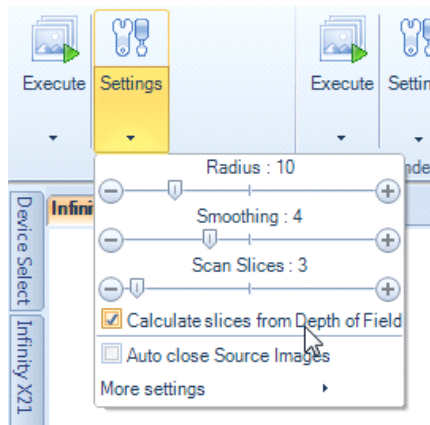



### 15.4.3 Automatic Extended Focus with Extended Exposure

To combine Extended Focus with Extended Exposure, check the **Extended Exposure** checkbox.

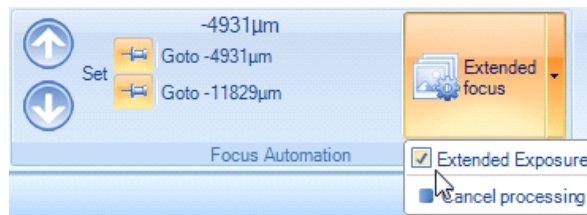

The process may take some time. The progress bar shows the ongoing work.

### 15.4.4 Auto Focus [from v6.6.7]

Click the 'Settings' button to configure the autofocus function.

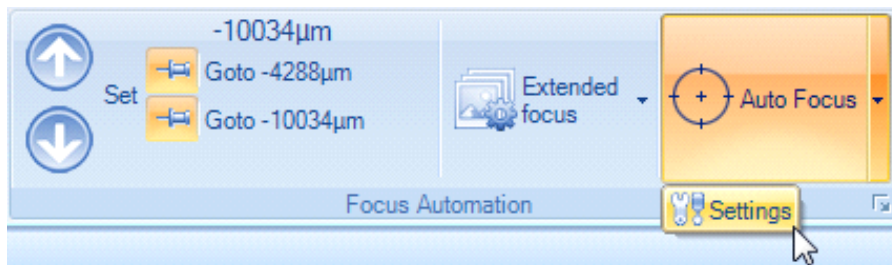

NOTE: By moving the mouse to the info-balloons, a brief explanation for the parameters is provided

If the objective used has defined 'DOF' defined in the 'Optics Editor', then this will be used as the actual DOF.

Some motorized zoom objectives automatically updates their DOF.

Check this check-box if the DOF is defined with the objective in the optics editor.

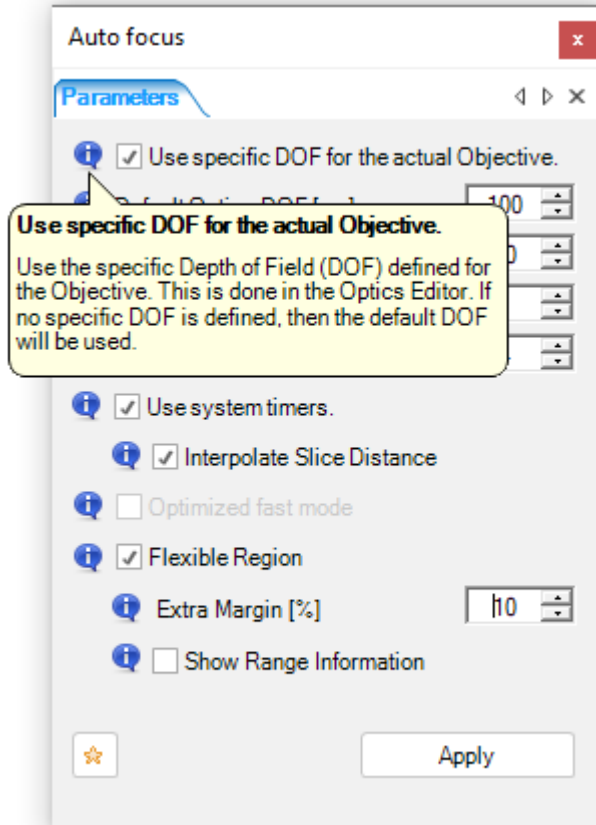

This is the default DOF is used if no specific DOF is defined for the objective

A narrow DOF will make the **auto** focusing slowly – a wider DOF makes it faster.

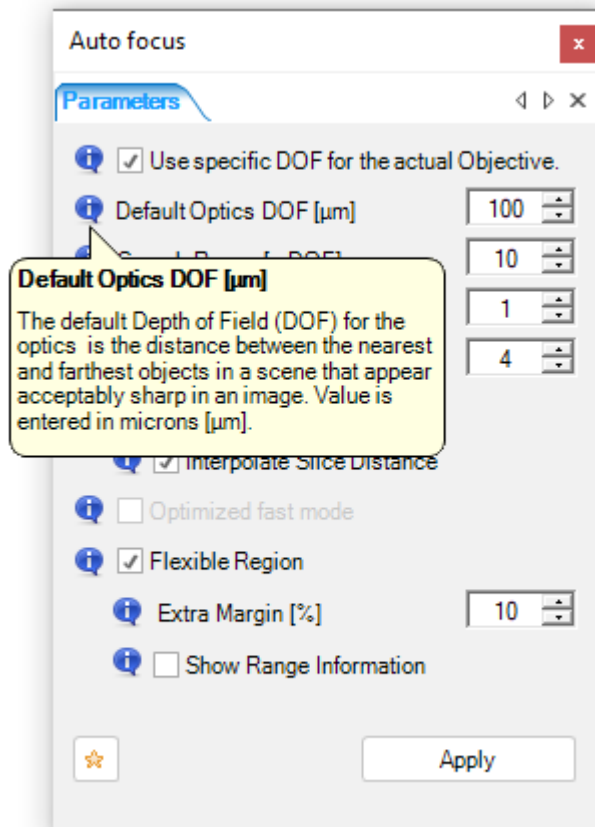

The 'Search Range' defines the maximum interval to look for a good focus.

Note that the value is entered in units of the DOF.

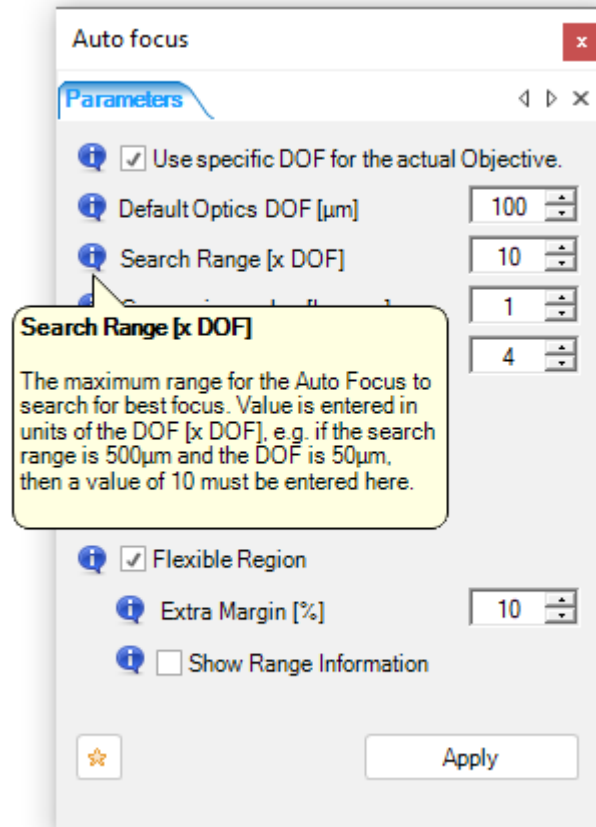

The 'Camera image lag' is a camera specific parameter, defined by the number of images in the pipe line from the camera.

To make a precise **auto** focus this must be entered; in most cases 1, 2 or 3 images will give a good result.

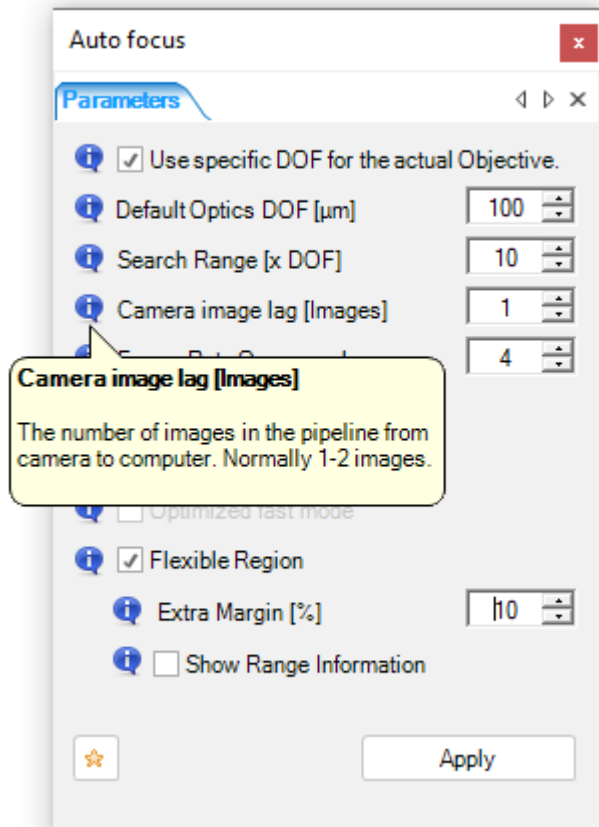

The frame rate oversampling sets how many images are analyzed within each DOF.

Example1: If the value is 1, and the DOF is 100um, then the focus is checked for every 100um move of the focus axis.

Example2: If the value is 4, and the DOF is 100um, then the focus is checked for every 25um move of the focus axis.

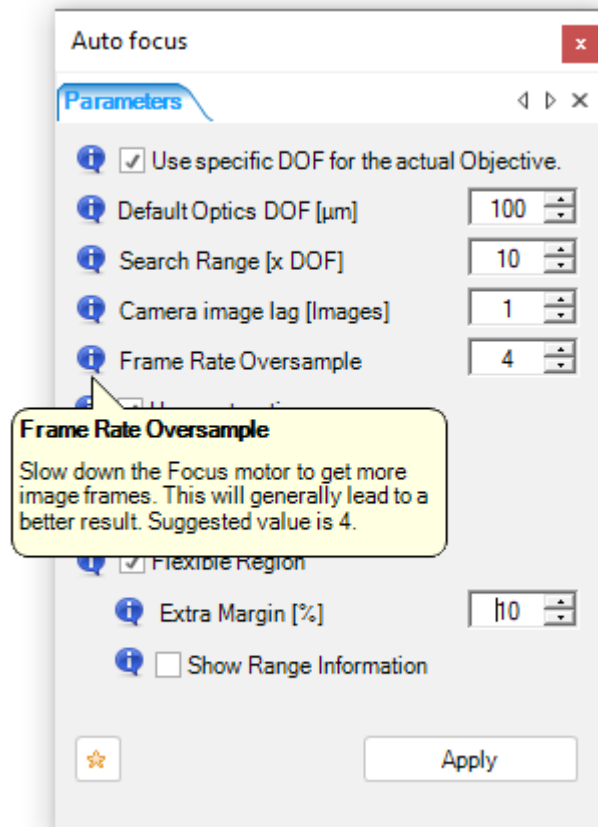

With some motor controllers, the best result is achieved by using a system timer to calculate the best focus position.

If the system timer is not used, then the position must be continuously read from the controller (which sometimes is a problem!),

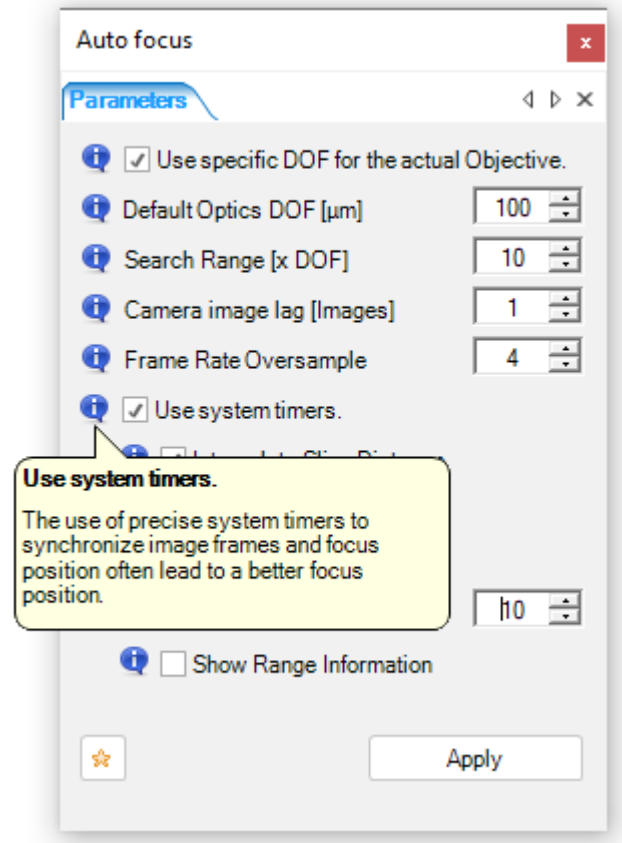

The result may be improved further by interpolating the focus slice distance - this allows the auto focus position to be in between two sample positions.

If this option is unchecked, the sample position with the maximum focus will be chosen as the best auto focus position.

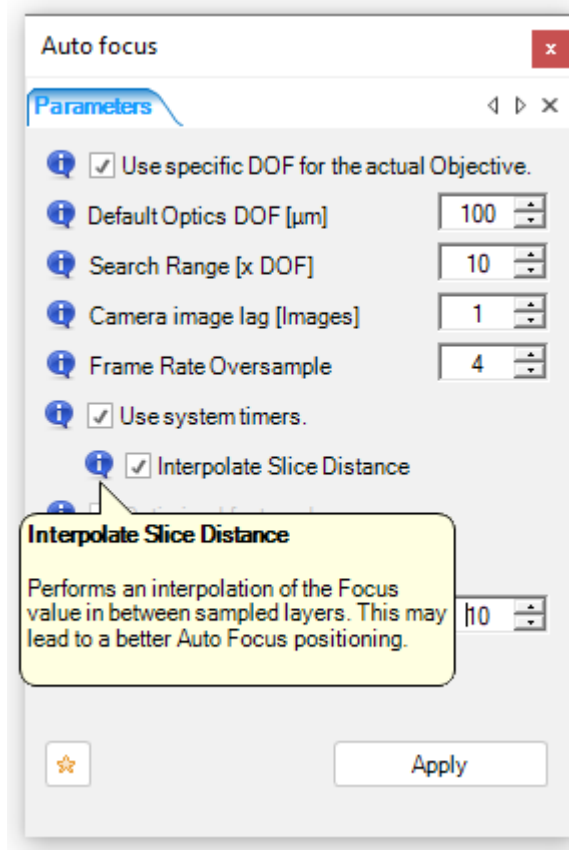



The 'Optimized fast mode' check-box allows for a faster [auto](#) focus, this will work best if the focus is not too far away.

In any case the search is limited by the 'Search Range' interval.

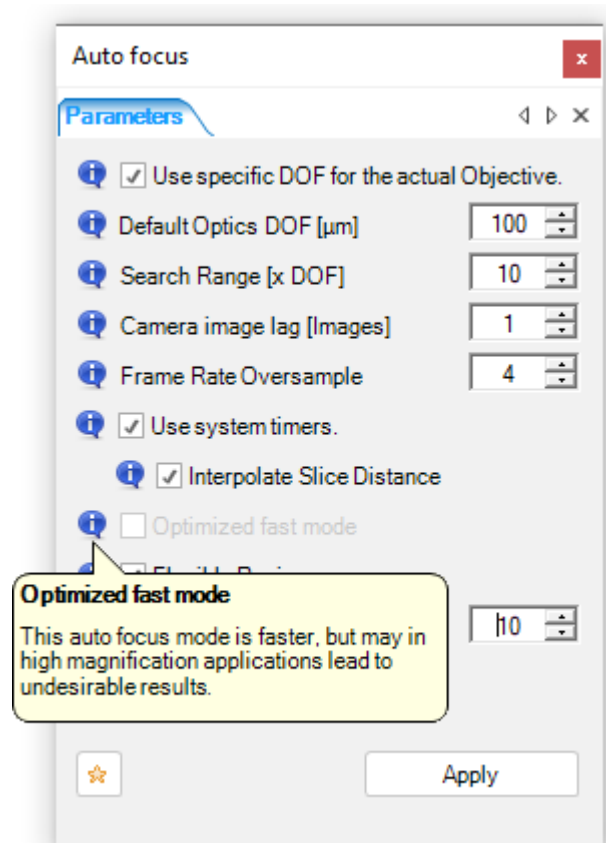

This check box defines the mode of the one zone auto focus.

If box is checked, then a flexible region is used. This zone must defined prior to running the auto focus.

The region is flexible in position and size.

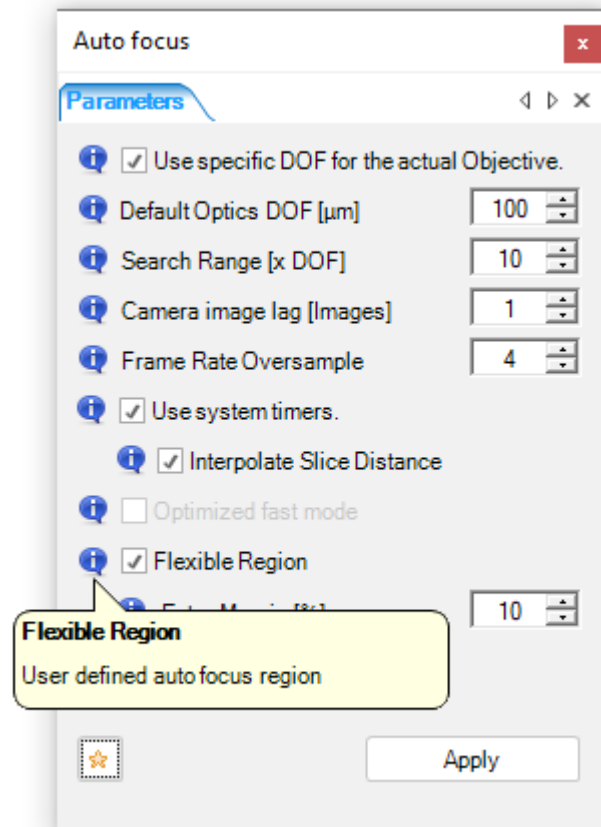

If using the two zone auto focus, a top and bottom level is determined.

For subsequent operations, like extended focus or topography/3D, an extra margin can be added to the range - this is entered as a percentage of the distance from bottom- to top-level.

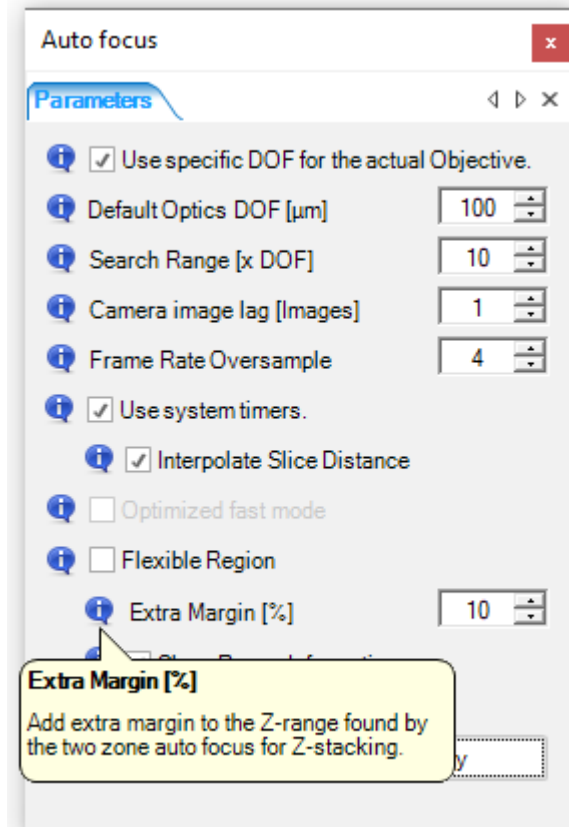

If using the two zone auto focus, a top and bottom level is determined.

When the bottom- and top-level is found, a pop up can be requested to show the levels before more (time consuming) processing.

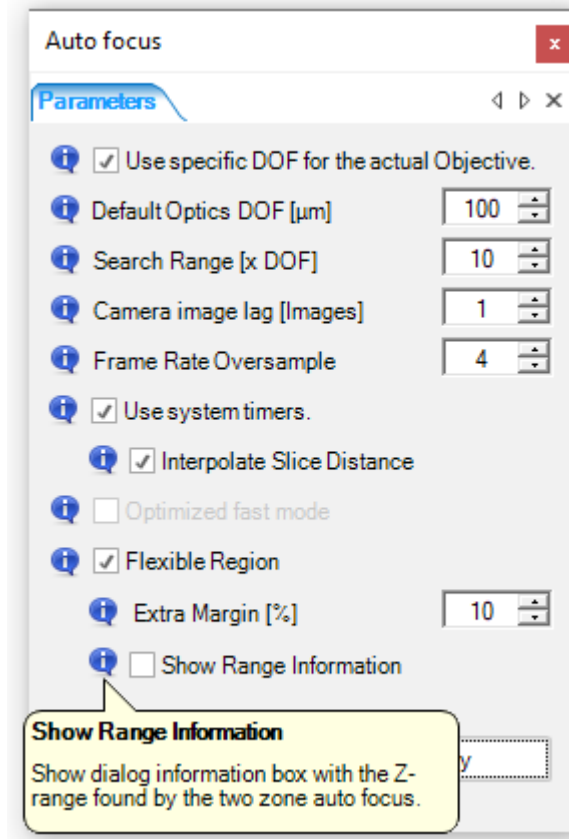
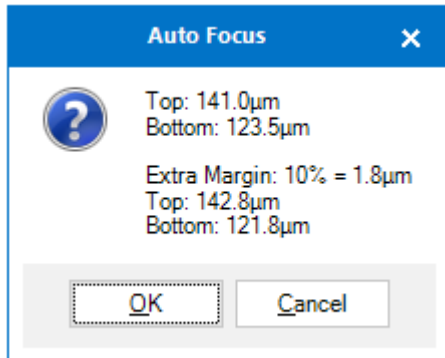

The 'Star' button loads the default parameters.

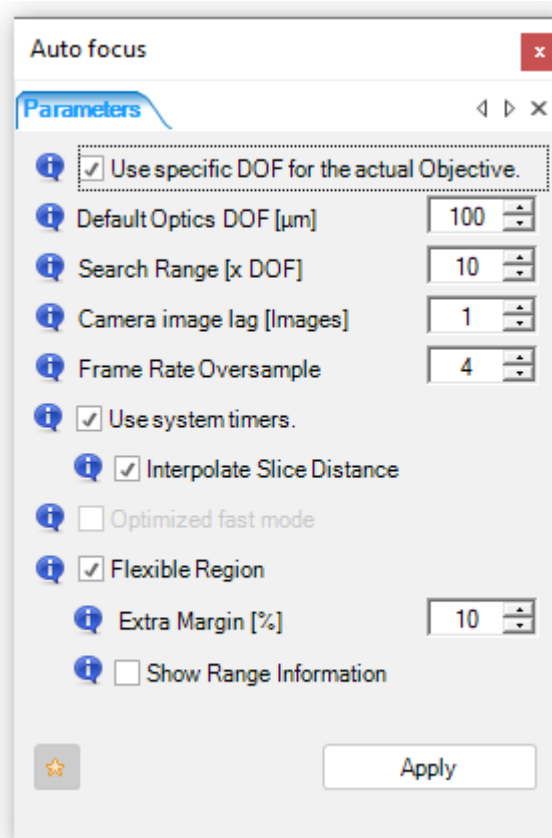

#### 15.4.4.1 One region Auto Focus

The [auto](#) focus works alone or in combination with:

Alone, just to focus the live preview image before capturing

- Before Extended Focus. This makes the need for very many z-slices less demanding.
- With Extended Field (Stitching)
- With XYZ- acquisition.

Two modes is available, center weighted image or region.

The mode is selected in the auto focus settings panel.

**Tip: By Ctrl-Alt-Click on the**  
**This for testing purposes only.**



button - the the actual region is indicated in fake color.

#### 15.4.4.1.1 Global center weighted Auto Focus

If using the global image auto focus, just click the auto focus button



#### 15.4.4.1.2 One Region Auto Focus

To use the region auto focus the region must be defined prior to running the auto focus.



Click the button, and click on the live preview image to position the region.  
Click one time more to lock the position.  
Then the region can be sized.

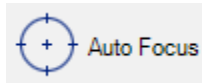

When region is defined just click the button to run the auto focus.

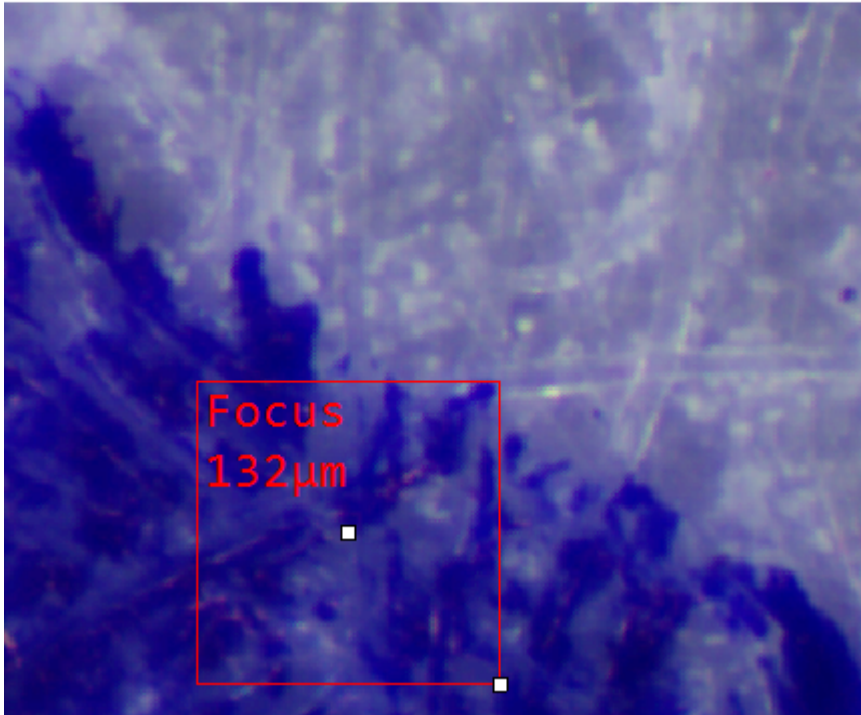
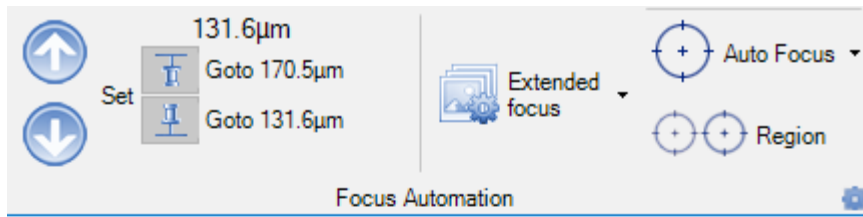

#### 15.4.4.2 Two region Auto Focus

To use the two region auto focus the regions must be defined prior to running the auto focus.

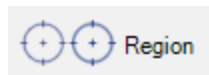

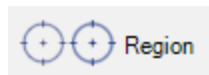
Click the  button, and click on the live preview image to position the bottom-level region.

Click one time more to lock the position.

Do the same for the top-level region.

Then the region can be sized.

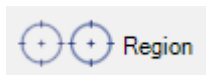

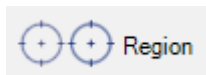
When region is defined just click the  button to run the two region auto focus.

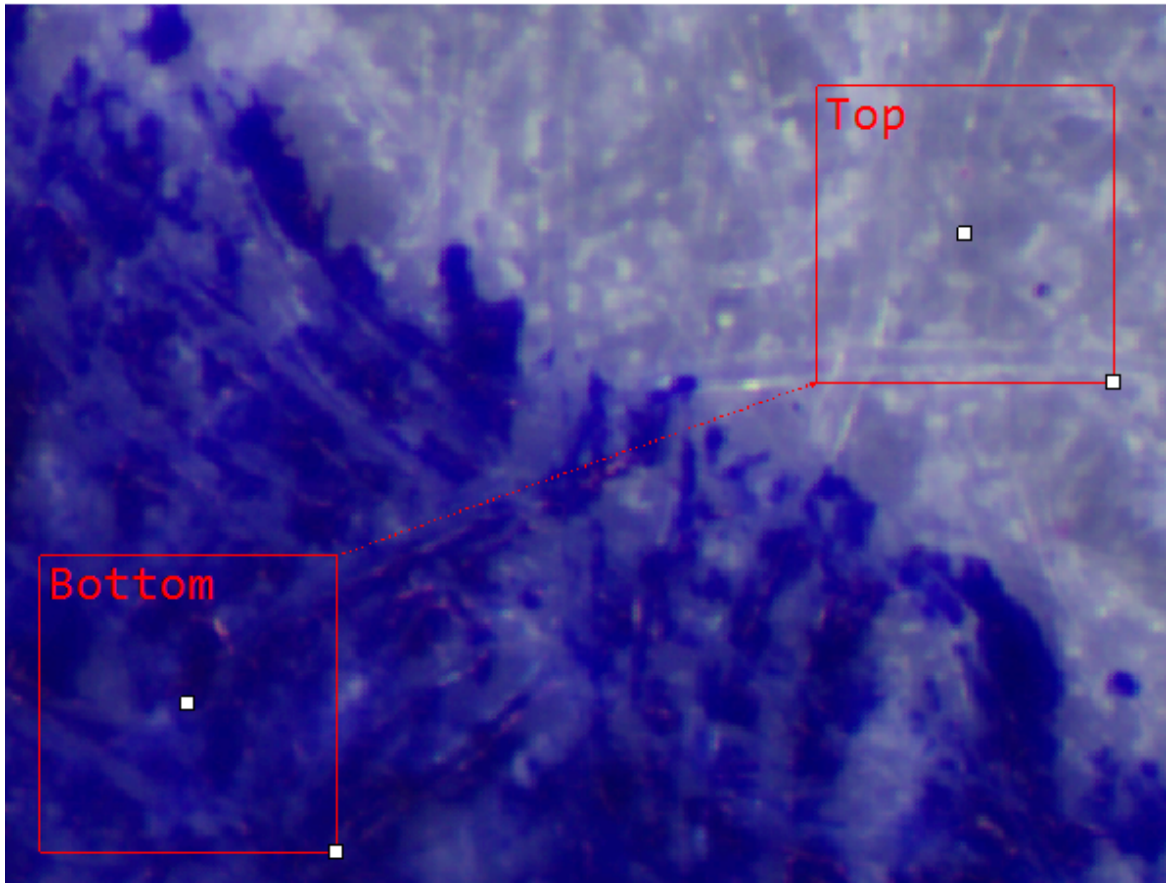
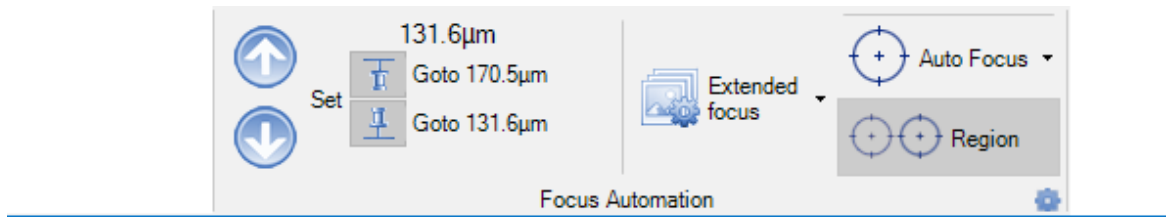

After the focusing, bottom- and top-level values are transferred to the Focus Automation panel - then extended focus or topography/3D can be run with ease.



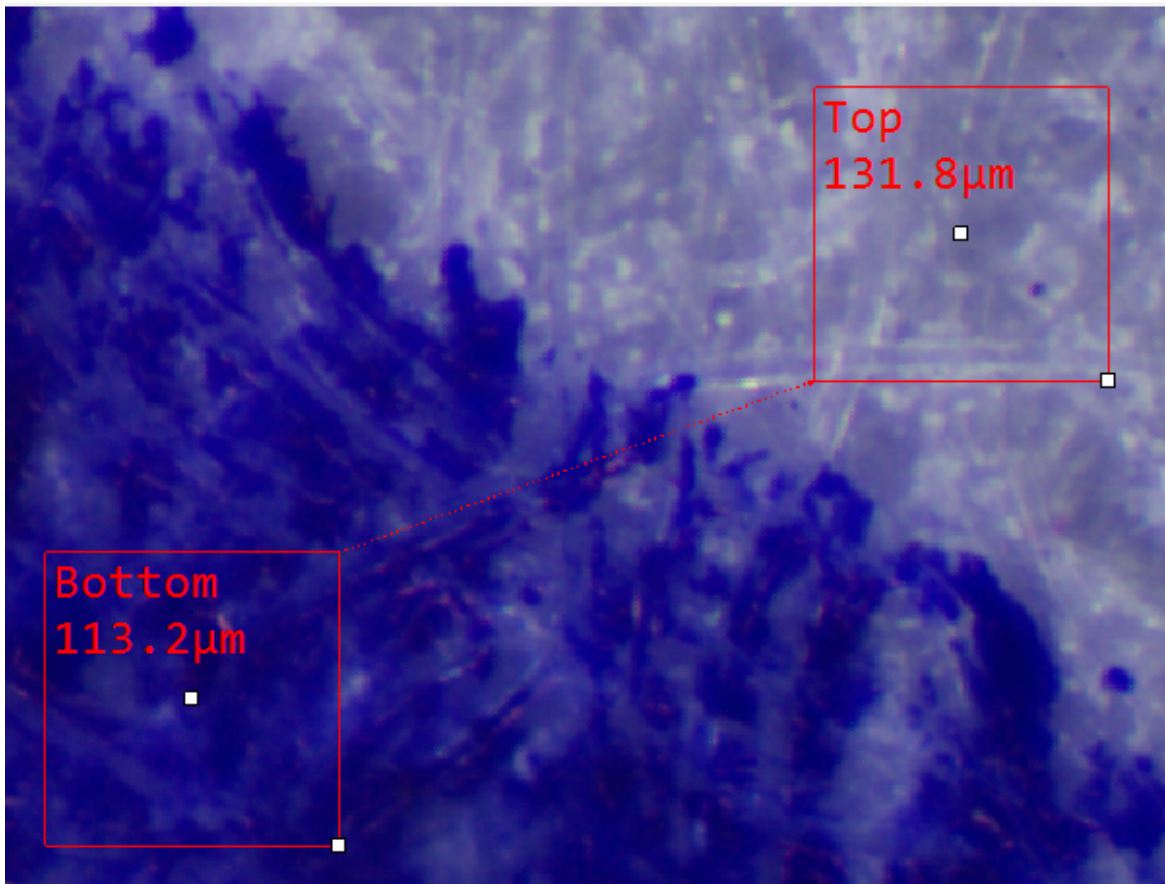
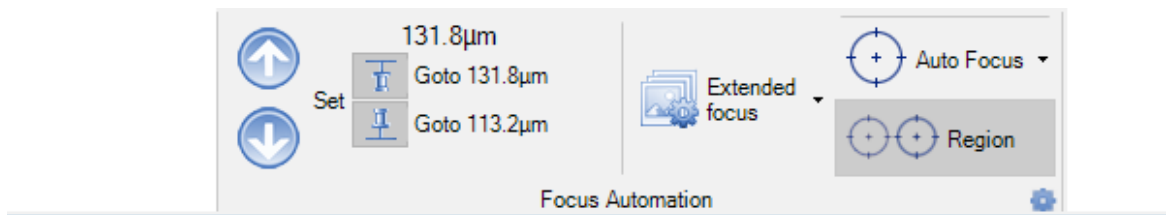

After two zone auto focus. The regions show the z-level values.

Note: If zones are defined, you can also simply click extended focus or topography buttons directly.

### 15.4.5 Making the motor speed relative to the DOF

Most motor controllers can be configured to make their focus speed relative to the DOF. In practice this sets the speed lower if the DOF is lower. As example a 25µm DOF will run at 25% of the speed of a 100µm DOF.

**The speed set in the focus controller panel will be used for the highest DOF. The DOF must be defined in the Optics Editor.**

## 15.5 Zoom Automation

The Zoom Automation is used for controlling a motorized Zoom objective.

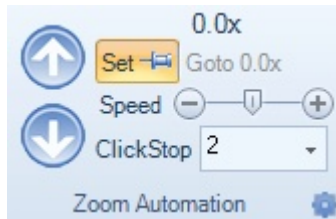

### 15.5.1 Zeiss MTB



Note: The zoom automation is only available for Zeiss microscopes with motorized zoom.

Click the up/down buttons to change the zoom factor,  
The actual magnification is displayed.



A specific zoom position can be memorized by the 'Set' button.

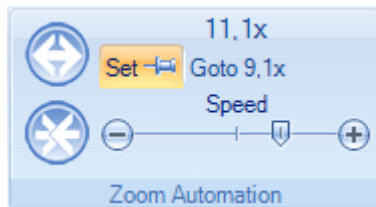

**NOTE: The Zeiss Zoom control is configured and connected with the focus control!**

**NOTE: Requires a well configured MTB2011 server. See [Installing and connecting to Zeiss MTB 2011](#)**

## 15.5.2 DeltaStep4

The controller communicates via a virtual serial port. This is easily identified as a 'Silicon Labs CP210x' device.

If this is not already automatically selected, select it and click connect.

When successfully connected, a green check mark is shown.

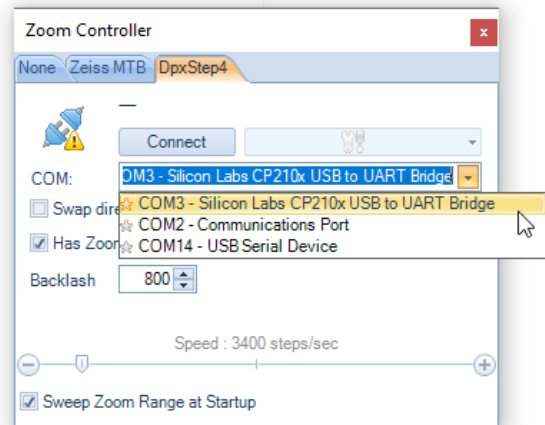

### **IMPORTANT:**

**When using pre-calibrated optics - an objective with a objective description file (see section Optics Editor for more on this topic). The "Sweep Zoom Range at Startup" check box MUST be checked for proper initialization of the motorized zoom objective.**

The **tools drop-down** shows the power supply of the controller. Both Running and standby current can be set.

The polarity of the limit switches can be set. To change the polarity check-box value, the shift key must be pressed while clicking – this is to prevent unintended change.

**Utmost care must be taken: Selecting the wrong polarity may damage your motor device!**

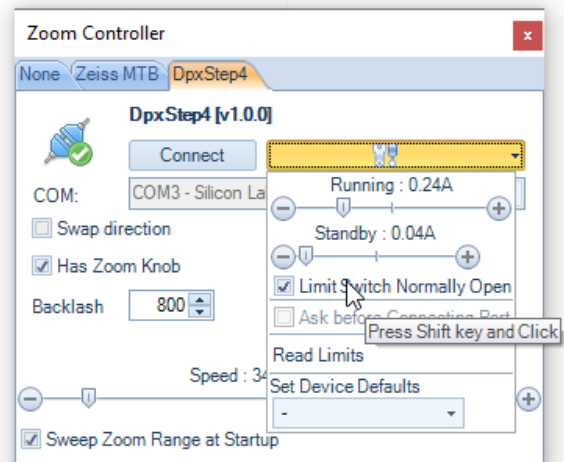

If the controller has zoom knob control, then automatic read back of position can be enabled by checking the 'Has focus knob' check box.

### **Backlash**

The backlash can be set, this may result in a more precise zoom value - especially when using the click stop values.

The value is entered as full stepper motor steps, so the best value depends on the stepper motor and optional gearbox.

## **16 Accessories Tab**

### **16.1 Zeiss microscope controls**

DeltaPix InSight can control most motorized/encoded microscopes. Version 3.2+ can control or listen to:

- Objective changer
- Tubelens turret changer
- Reflector changer
- The Reflected Light Shutter

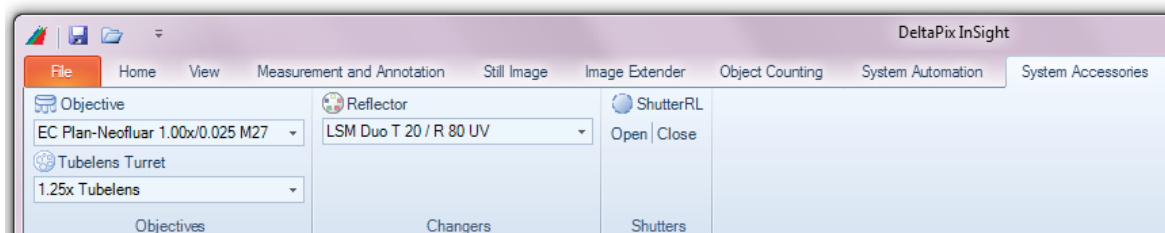

In order to make calibration work, one trick is necessary:: You will also need to define the objectives in the optics editor – and in the SAME order as in the "Objective" drop down menu. The order in the "objective" drop down is determined by the MTB2011. Then selecting another objective from this drop down, will also change the objective on the microscope.

**NOTE: Requires a well configured MTB2011 server. See [Installing and connecting to Zeiss MTB 2011](#)**

### **16.2 Mettler Toledo Hot Stage HS82**

The Mettler Toledo Hot Stage HS82 can be controlled from DeltaPix InSight, a temperature profile can be defined.

The Stage is connected via a serial port.

The temperature data is read once every second – and the actual temperature can be rendered into the image bitmap in Celcius or Kelvin. So it should also be visible for a lapse time recording.

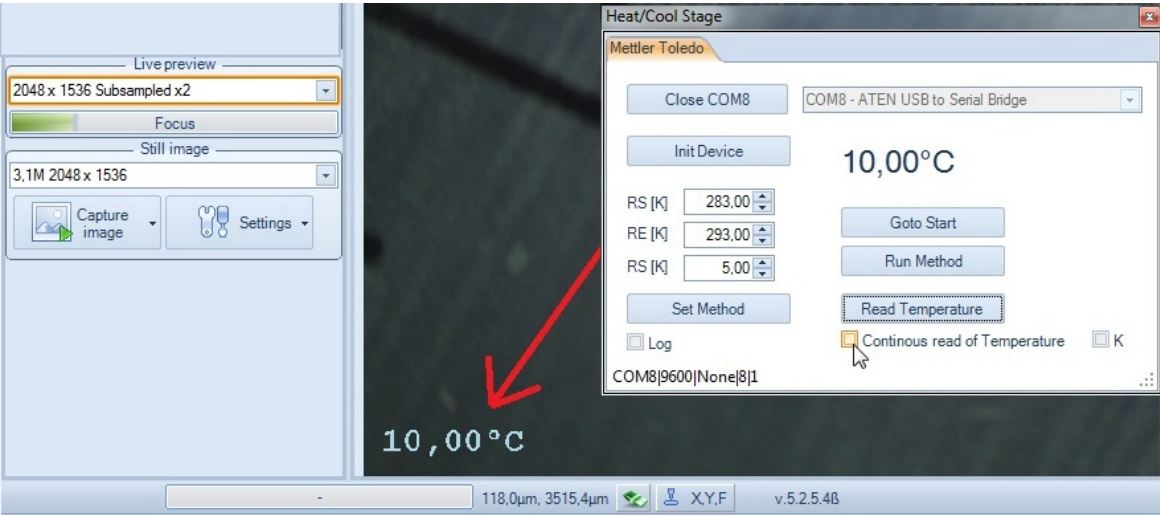

## 16.3 PixLight Ringlight (Valid from InSight 6.4)

The DeltaPix PixLight ring light comes in different versions

- White/Red 5 zones.
- White/Blue 6 zones with zone or single LED light
- White/UV 6 zones with zone or single LED light

The ring light capabilities can be read from the ring light - and the GUI updates accordingly.

Selecting color

Click the color switch – white or blue in this example.

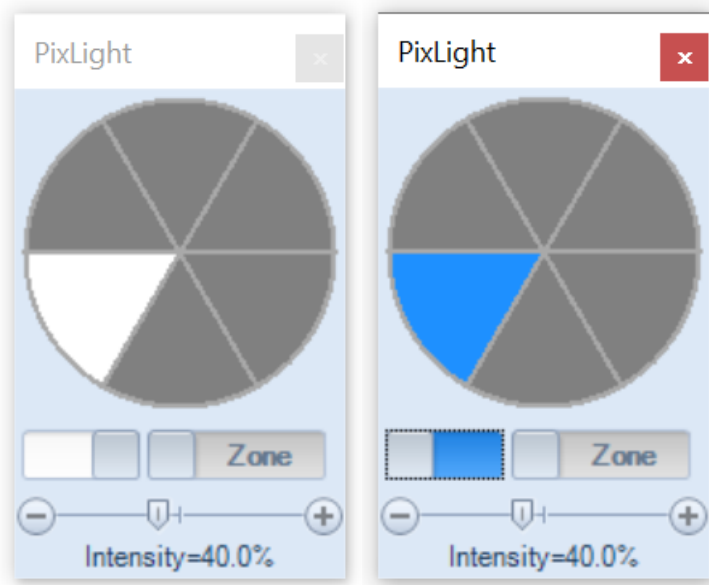

Zone or single LED

If the ring light supports single LED light, then the Zone/Single switch is enabled.

Click the zone/single switch – to select zone or single LED light

Using single LED light is essential when doing photometric.

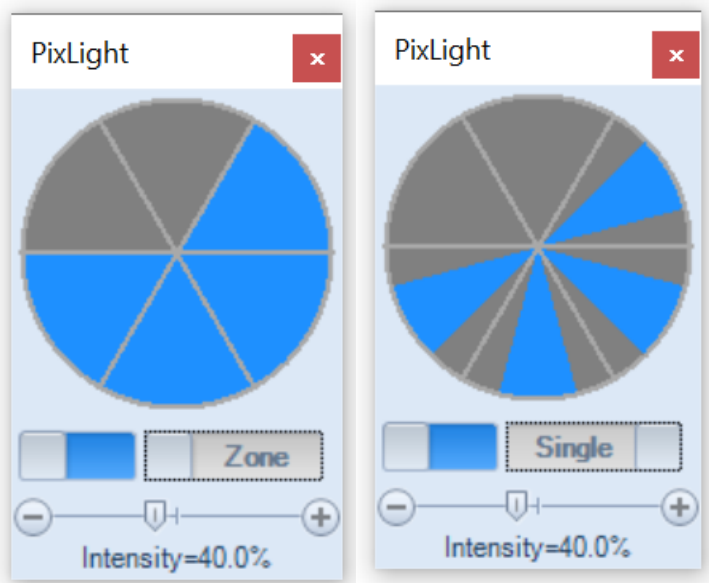

Intensity

The light intensity can be set by the Intensity slider.

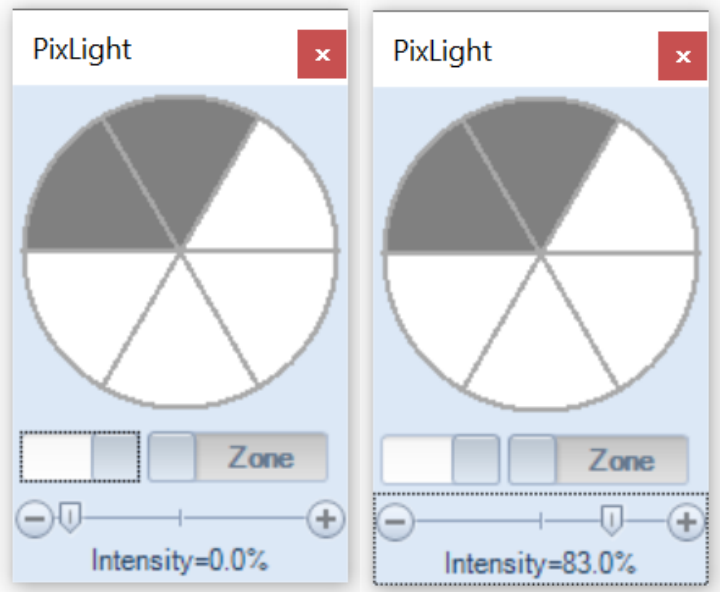

Key switch

Activating the (optionally) key switch will switch to the primary color and lock the color selector.

The key switch is aimed to protect against UV light.

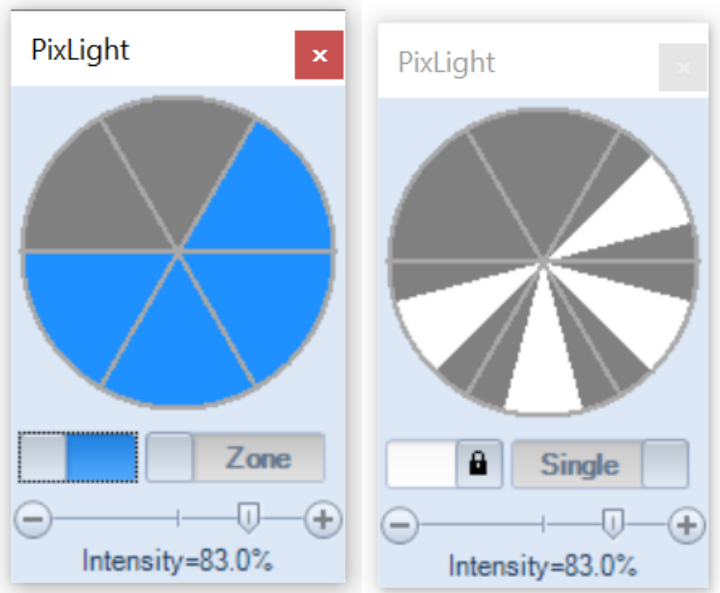

## 16.4 Objective change scanning

By attaching a dot- or bar-code to each objective position, it is possible to make the objectives encoded in a smart way.

The associated calibration will automatically be applied.



Just below the bar code button, the most recent read code is displayed, in this example "<2>"

Objectives are indexed 1..N, and the label for e.g. objective #3 should contain the string "<3>".

**IMPORTANT: Objectives MUST be labeled in the same order as defined in the optics definition editor.**

Codes are easily created on-line from this page : <https://barcode.tec-it.com/en/QRCode>



Code for 1st objective "<1>"



Code for 2nd objective "<2>"



Code for 3rd objective "<3>"





Code for 4th objective "<4>"



Code for 5th objective "<5>"



Code for 6th objective "<6>"

### 16.4.1 Example: Askania 6Z

The Askania 6Z stereomicroscope does not have stepless zoom, but has 6 precise click stops:

1. 0.32x
2. 0.63x
3. 1x
4. 3.2x
5. 1.6x
6. 1x (physically the same as click stop 3)

This should be defined in the optics editor like:

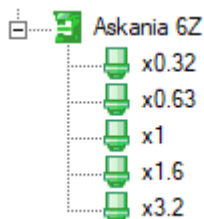

**Note:** the magnifications get sorted in ascending order.

Since the code labels refers to the index in the optics editor, the code labels should be arranged in the following sequence:

1. <1>
2. <2>

3. <3>
4. <5>
5. <4>
6. <3>

## 17 Image Compare

### Valid from DeltaPix InSight v6.2.9

Images can be compared in a number of ways.

The compare functions in many ways replicated the functionality of a traditionally 'analogue' comparison microscope – but much simpler and more flexible to use. Only one light setup is required – no need to do tedious work to set up identical right and left sides.

A reference image can be directly captured from the live camera image, or a stored still image can be set as reference.

The 'Compare Image' is located in the 'Image Compare' tab.

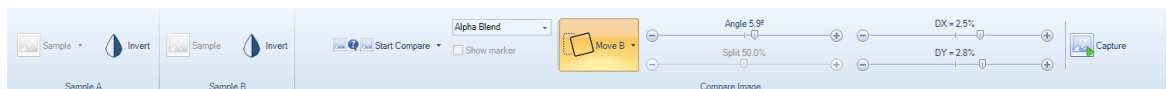

Sequence to prepare a compare session:

1. Select the "Sample A". This can be a still or the camera live image. Optionally a live comparison can be done, then select from the drop down.
2. Select the "Sample B". This can be a still or the camera live image.
3. Click the "Start Compare". This will spawn a new comparison image.
4. Different kinds of comparisons can be done, select from the drop down combo box.-
  - None - no comparison is done
  - Difference - the images are subtracted.
  - Alpha blend - the images are added, 50% from each.
  - Horizontal - the images are split and shown side-by-side.
  - Vertical - the images are split and shown side-by-side.

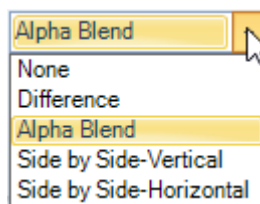



Example: Alpha Blend



Example: Vertical side-by-side.  
Use the split slider to place divider.



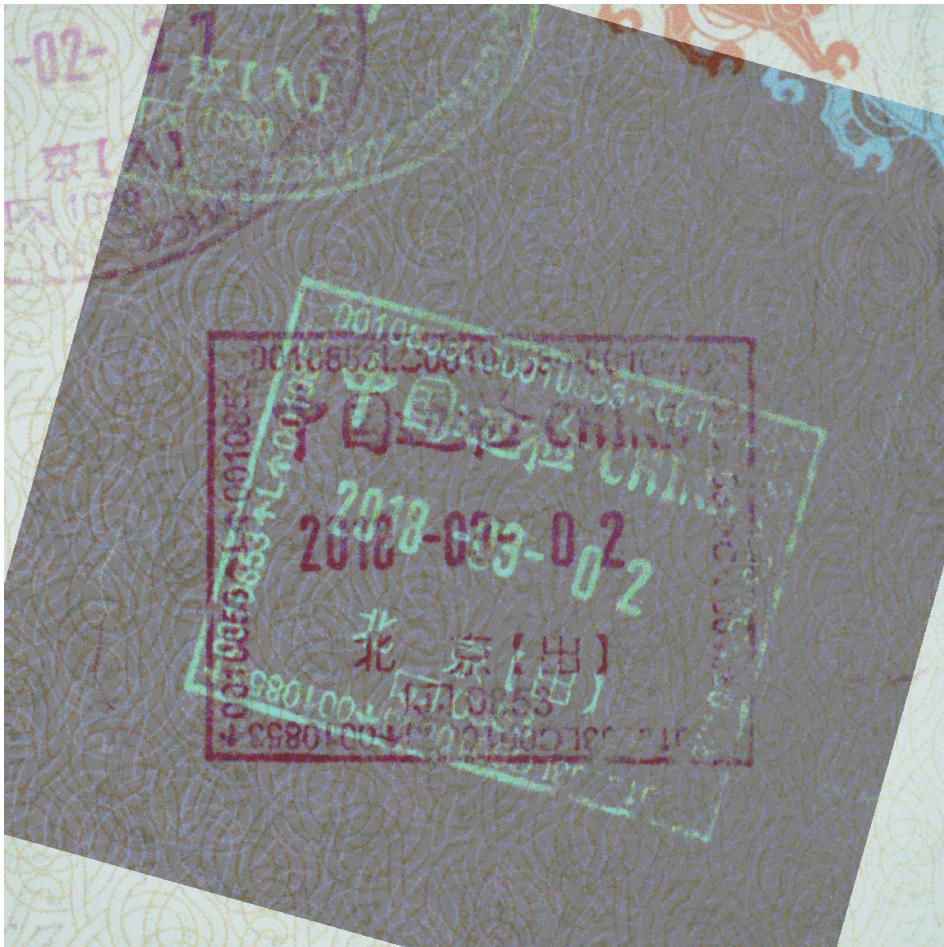

Example: Alpha Blend, one image is inverted



Example: Difference, one image is inverted

### **Aligning the Sample B.**

The sample B can be aligned using the Angle, DX and DY sliders.

*Note: The DX and DY range can be extended by Alt and Ctrl modifier keys:*

- the Alt Key extends by a factor of 2
- the Alt Control extends by a factor of 2
- the Alt+Ctrl Key extends by a factor of 4

Alternatively the sample B can be aligned using the mouse.

- Use the mouse wheel to rotate.
- Push the mouse button and drag the image.

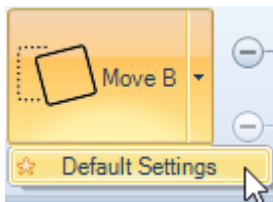

### Comparison options.

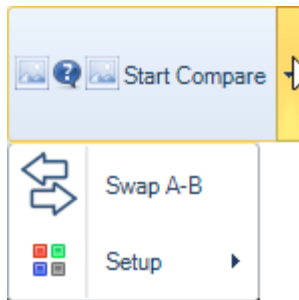

The Sample A and B can be swapped

The "Setup" button defines a remapping function – it applies to both the live and the reference image.

This can enhance e.g. the evaluation of difference comparisons.

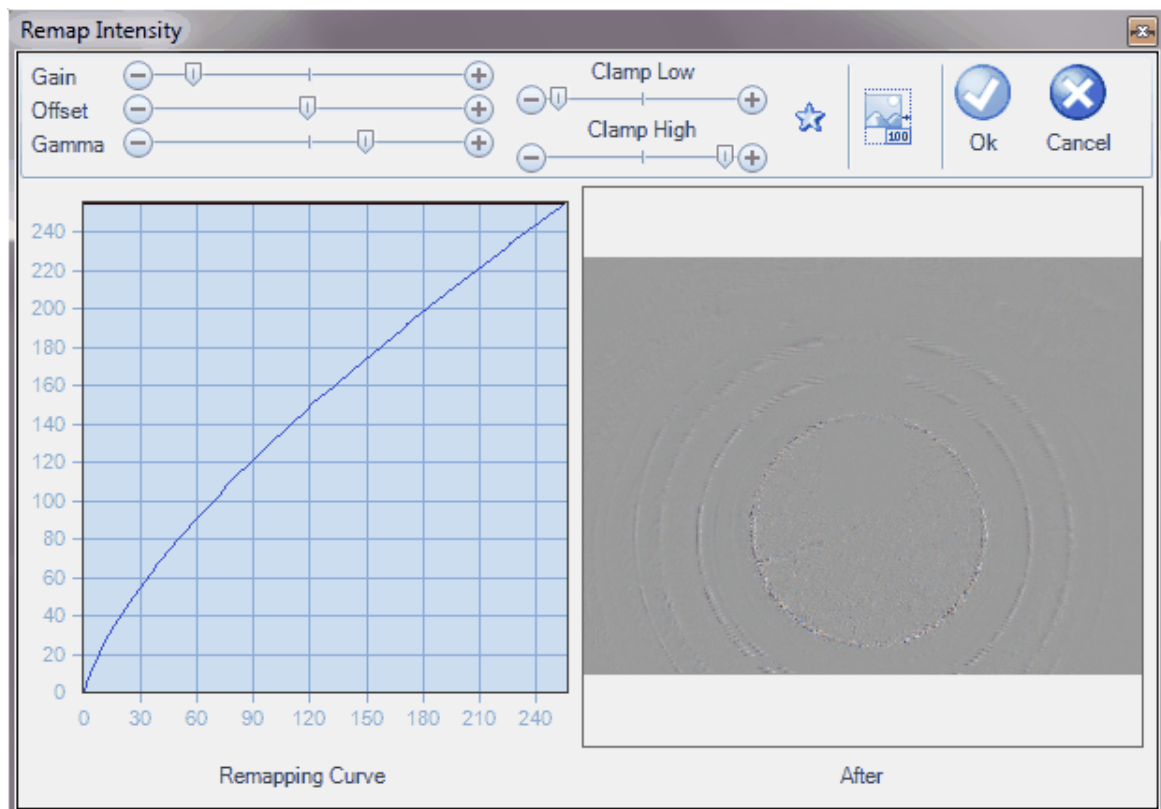

## 18 Topography [from v6.4.0]

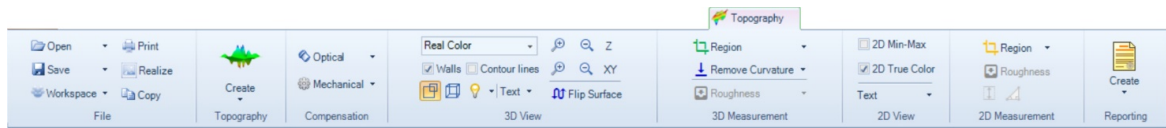

DeltaPix InSight can create 3D surface from a Z-stack of images.

High-precision topography measurement using focus techniques can be realized provided that the in-focus plane of an imaging system is very accurately determined.

To create surface charts, it is highly recommended to use medium resolution images, ~2 MP images are sufficient. More pixels will slow down the processing, and potentially limit the number of images in the Z-stack

**i** | The topography processing and display requires a powerful computer to ensure fast creation of images and smooth display.

### Precision of the topography

Precision can be better than 1 micron, dependent on optics magnification, focus motor precision and light quality. Several factors influence the precision:

1. A low depth-of-focus (DOF) is desirable. High magnification and numerical aperture generally decrease the DOF.
2. The number of focus slices acquired for processing. If many slices are used the better precision. As a rule of thumb, the slice distance should be less than the DOF, around 1/2 DOF to 1/4 DOF is recommended.
3. The best Z resolution is 1/250 of the Z used travel range, so if the difference between top and bottom level is 1mm, then the very best precision is  $1000\mu\text{m}/250 = 4\mu\text{m}$ .
4. The precision is also limited by the number of Z-stack images used. As worst-case example, if only 3 images are used, and the difference between top and bottom level is 1mm, then the precision is  $1000\mu\text{m}/3 = 333\mu\text{m}$ . The result may look better since a configurable interpolation and noise reduction between the Z-stack layers is done.
5. The surface of the object. Shiny or black surfaces generally are difficult to handle.
6. The precision of the mechanics – primarily the focus motor. This is however normally in the um-range.



## 18.1 File

The topography offers several ways of saving, opening and copying 3D data.

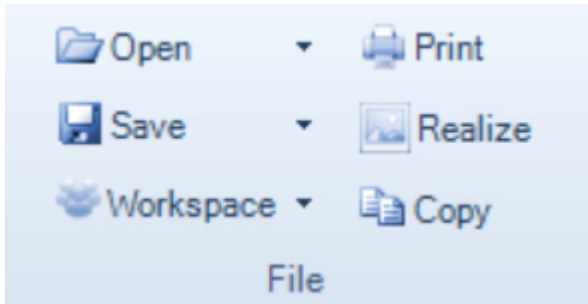

### Print

A topographic 3D view can be printed to any type of standard printer.

### Realize

Realizes the topographic image currently shown.

The 3D surface or 2D profile image will be saved as a 2D image. This image can be viewed in most graphics programs.

### Copy

Copies the 3D surface or 2D profile image currently shown to the clipboard as a realized 2D image.

This image can be pasted into most graphics' programs.

The chart can then be inserted in e.g. a Microsoft Word document.

### 18.1.1 Open

Open previously saved topography images, 3D surface or 2D profile.

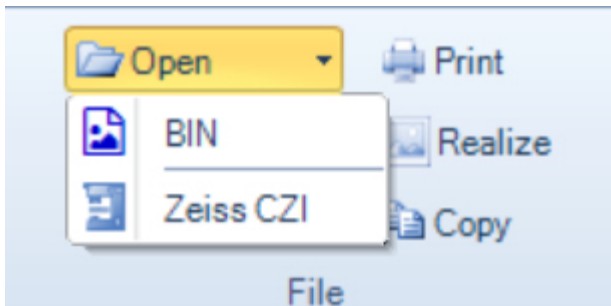

The bin-format is a proprietary binary format.

#### Zeiss

An image stack acquired from a Zeiss microscope (e.g. using Zen), can be opened and processed to a topographic 3D image.

### 18.1.2 Save

3D images can be saved in a variety of file formats.

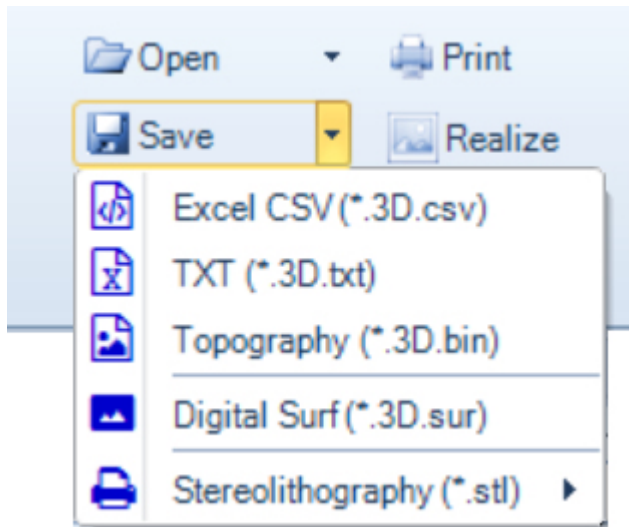

Topographic 3D images can be saved as comma-separated-values, plain ASCII text, or proprietary binary format.

Alternatively, the 3D image can be saved in a Digital Surf compatible format, for further analysis in the Digital Surf Mountains Map software,

#### TXT format

Optionally the surface data can be exported as a flat CSV or TXT file.

The file format is proprietary but can easily be parsed by 3rd party software.

The format is <indexX>, <indexY>,<ValueX>, <valueY>, <valueZ>, <red>, <green>, <blue>, <alpha>

```
//-----
// DeltaPix InSight
// Chart has 160 x 106 datapoints.
// Unit XY is 0,011mm / point
// Unit Z is µm
// Saved: 20-10-2019 09:41:30
//-----
0000; 0000; 00000,000; 00000,000; 00003,063; 145; 125; 156; 255
0001; 0000; 00000,011; 00000,000; 00003,063; 144; 129; 163; 255
0002; 0000; 00000,021; 00000,000; 00003,063; 125; 126; 150; 255
0003; 0000; 00000,032; 00000,000; 00003,063; 153; 134; 153; 255
0004; 0000; 00000,042; 00000,000; 00002,784; 136; 131; 145; 255
0005; 0000; 00000,053; 00000,000; 00002,784; 136; 123; 148; 255
0006; 0000; 00000,063; 00000,000; 00002,506; 138; 119; 152; 255
0007; 0000; 00000,074; 00000,000; 00002,506; 138; 123; 155; 255
0008; 0000; 00000,084; 00000,000; 00002,227; 144; 131; 163; 255
0009; 0000; 00000,095; 00000,000; 00002,227; 143; 137; 163; 255
0010; 0000; 00000,105; 00000,000; 00001,949; 150; 133; 158; 255
0011; 0000; 00000,116; 00000,000; 00001,671; 141; 137; 156; 255
```

### Stereolithography

To export the topographic 3D surface to a 3D printer, the stereolithographic STL file format can be used.

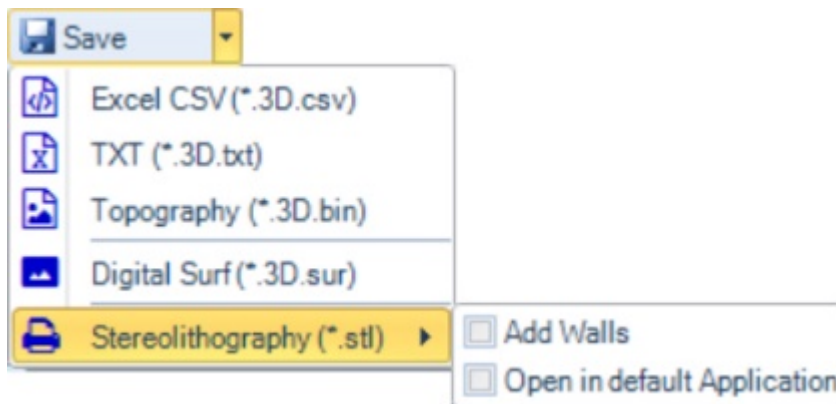

The STL file can have side walls added, and optionally automatically opened in the default STL application after creation.

### Workspace

Different topographic workspaces can be saved, this makes the switch from one topographic analysis type to another easy.

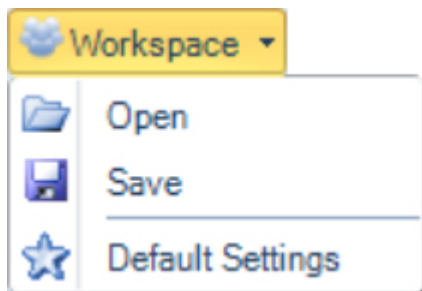

Save your topography workspace for a specific analysis, and simply load it next time the same task needs to be done.

## 18.2 Topography

The topography 3D creation can either be done by acquiring Z-stack images manually, or fully automated using a motorized focus microscope.

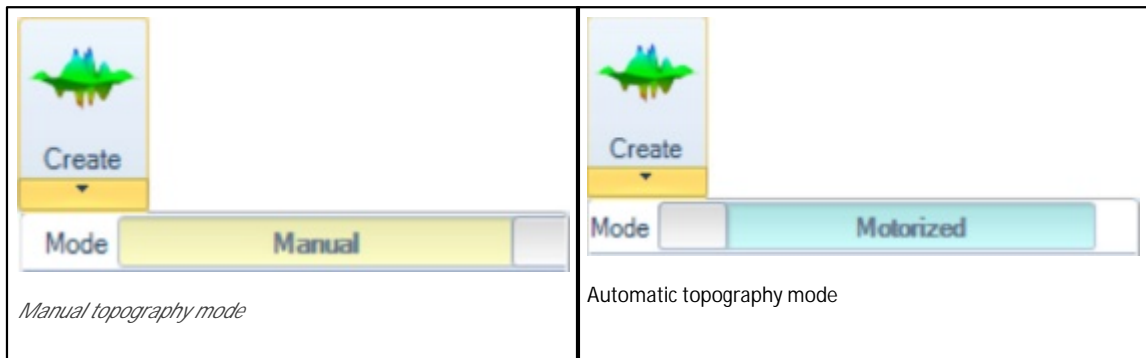

### 18.2.1 Manual Topography

It is possible to create a topographic image without motorized Z axis – but to have a good image the manual capture must be done equidistant at the Z axis.

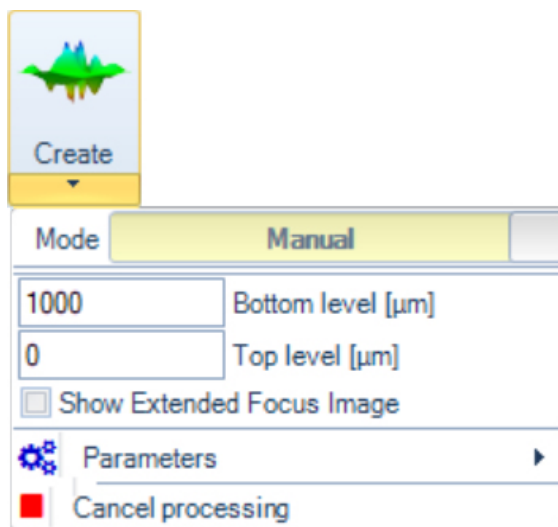

To have the right scaling, the top and bottom level must be entered.

**i** Note: that if both top- and bottom-level is set to 0, then an automatic scaling will be done.

### 18.2.2 Automatic motorized Topography

Performs an automatic image capture and topographic processing.

The number of images can be set up manually or calculated from the requested slice distance.

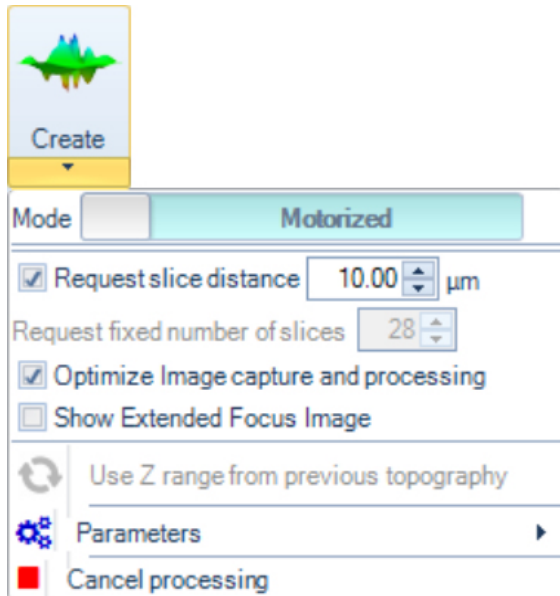

By checking the 'Show Extended Focus Image' check-box, the Extended Focus image is shown after the topographic processing.

### 18.2.3 Use Z range from previous topography

This function can be used to narrow down the top and bottom positions, starting from a rough setting.

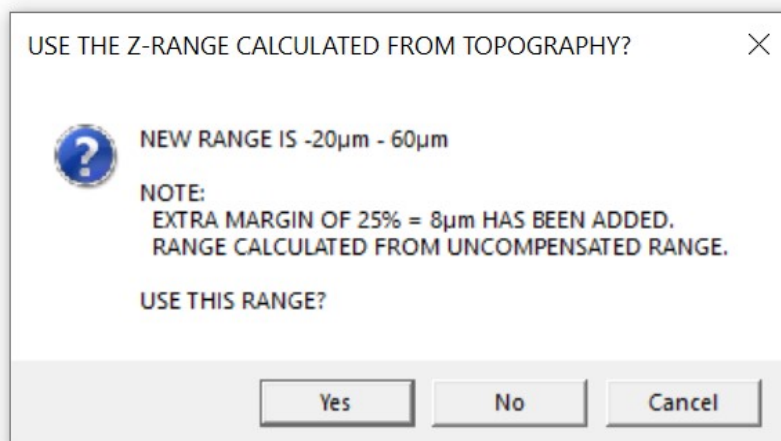

Click 'Yes' to use the suggested range, 'No' to continue, but not use the suggested range. Click 'Cancel' to skip the creation of a topographic image.

The function will use the topographic top and bottom levels and add a margin of 2 x 12.5%.

## 18.2.4 Parameters

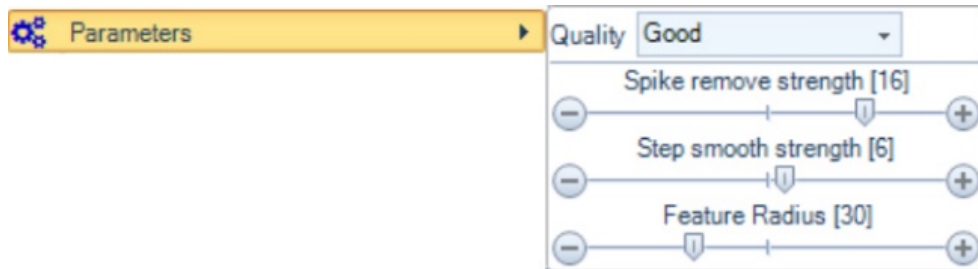

### Quality

Select the quality. Normally 'Good' quality is recommended.

Please note that the better quality, the better/faster computer is required!

### Spike remove filter

This parameter determines the strength of which height noise (but also image details!) is filtered away.

A larger value will give a smoother surface.

### Step Smooth Strength

This parameter determines the strength of which the height map is smoothed.

A larger value will give a smoother surface.

### Radius

Sets the radius within which to compare focus, to calculate the Z height. Radius is the control that sets the size of the analyzed area around each pixel.

Try different values. Start with a small value to see the result. Then, stepwise increase the value to remove noise, unwanted artifacts, or halos along the edges. For scenes with 'small' details a low radius of about 3-5 will produce the good results.

## 18.3 Compensation

### Optical compensation

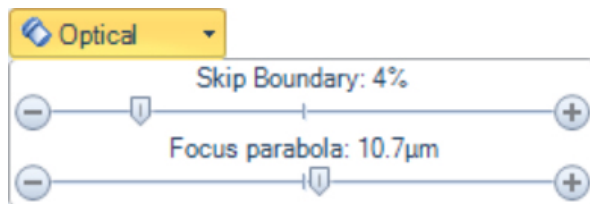

### Skip boundary

The boundary of the 3D plot may have weird bends due to the difficulties of determining the right focus plane.

In such cases the 3D may show up better if the boundary is slightly trimmed.

Suggested value is 3-5%

### Focus parabola

The boundary of the 3D plot may have weird bends due to the difficulties of determining the right focus plane. This is often due to non-telecentric objective or shift in a stereo microscope. In such cases the 3D may show up better if the boundary is slightly trimmed away. Suggested value is 3-5%

### **Mechanical compensation**

When making 3D plots of surfaces with very little height, it is very disturbing if the stage has a slight tilt.

This may be corrected by the X- and Y-tilt compensation.

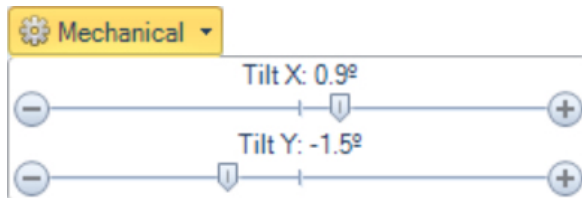

## 18.4 3D View

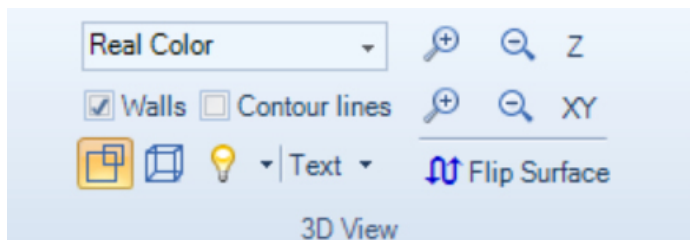

The entire chart can be zoomed using the XY or Z +/- magnifier buttons.

### **Color scheme**

Select an appropriate color. Most often the 'Real Color' option will be used as this reproduces the real object most naturally.

If the 'Zone' color is used, then the height can be read from the color legend. Each color in the legend corresponds to an input image, also representing the DOF.

### **Walls**

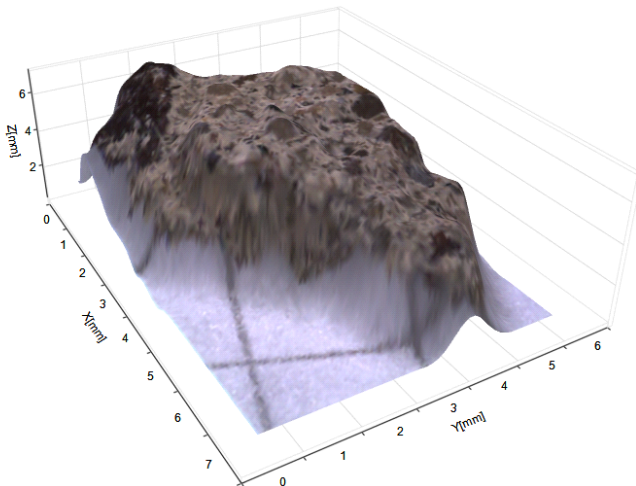

Part of the Berlin Wall – shown with Walls

### Contour lines

The 'Contour' option will show the image layers.

### Projection

Two options exist, perspective or orthogonal view.

### Light

Several artificial light models can be applied to change the contrast. For the 'Real Color' view, the 'None' option is recommended.

### Text

Header and footer texts can be added.

Annotations can be added by right clicking on a position on the 3D surface.

The callout will contain XYZ-information and the text in the 'Callout Text' text-box.

By mouse pointing the 3D line chart, the XYZ data is shown.

To add custom text to an annotation box, first select the annotation by clicking it with a mouse button. When selected, the color will change. Then type the text in the textbox.

### Flip Surface

This option inverts the surface, like it is seen from below.

Also, useful if e.g. the 3D surface Z-stack was acquired in the wrong direction.

## 18.5 3D Measurement

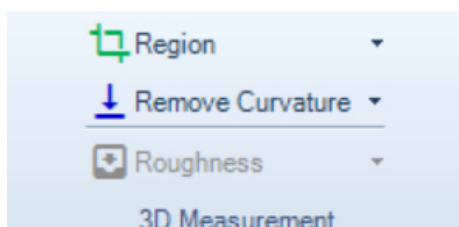

### Region



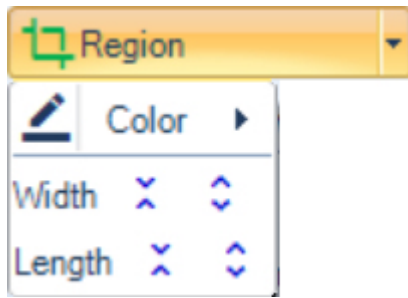

The wall color can be changed to enhance visibility.  
The narrow/widen buttons can be used to adjust the region.

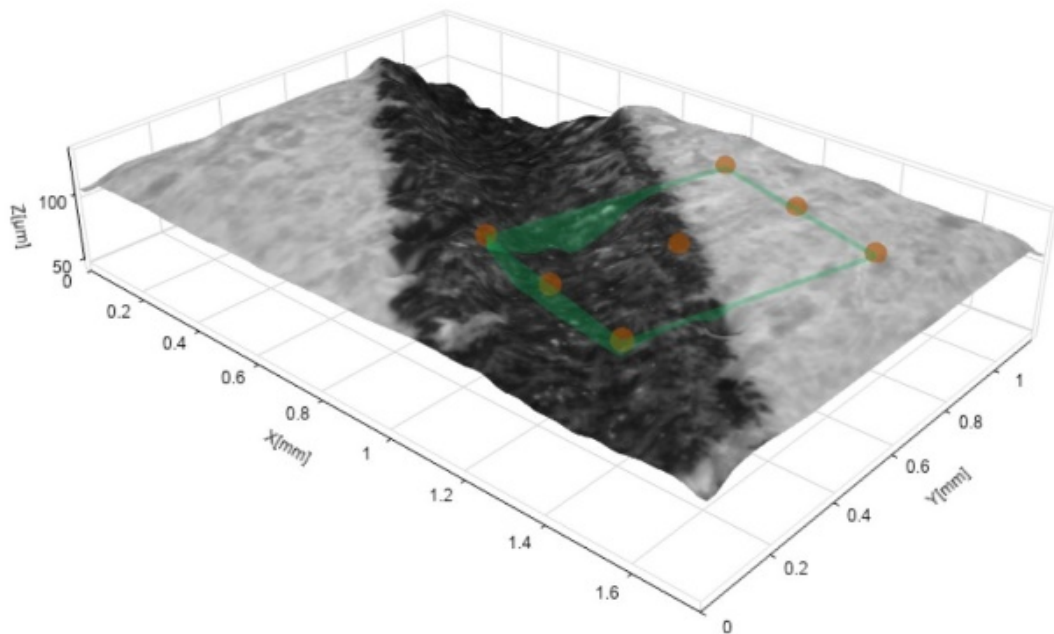

The best way to move a region is by mouse dragging the control bubbles. The control bubbles automatically show up when the mouse is moved within the 3D chart. The bubble color is always a 'complementary' color to the region color.

- The 4 corner points control the width and length of the region.
- The 2 midpoints control the length and angle of the region.
- The center point controls the overall position.

#### Remove Curvature

This feature can remove smooth large-scale variations. This is useful when doing e.g. roughness measurements on a curved surface.

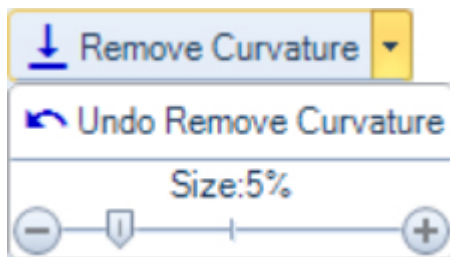

The curvature removal uses a dedicated filter.

The size of the filter can be set:

- If set small also small variations will be flattened away.
- If set large, only large variations will be flattened away.

- i Note: The boundary of the 3D image will become invalid when using this feature. Using a small value will only make a small fraction invalid, bigger values will make the invalid boundary bigger.  
The 'Skip boundary' parameter will automatically be updates to hide invalid boundaries.  
A value of ~5% is suggested for typical use.

The kernel size should be significantly larger than the 'roughness' to be measured.

Note: Focus parabola and stage tilt compensation should be set equal to 0.

## 18.5.1 3D Roughness

### Roughness

The Surface Roughness implements a subset of ISO 25178

Height and volume parameters can be selected via the drop-down check boxes.

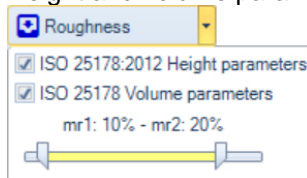

The volume parameter calculation offers settings for the mr1 and mr2 input parameter.

The parameters are associated to a topographic 3D image - data shown in a panel in the lower right corner.

ISO 25178	
Sq	= 1.07µm
Ssk	= -4.58
Sku	= 25.13
Sp	= 0.30µm
Sv	= 7.46µm
Sz	= 7.75µm
Sa	= 0.52µm
Vmp	= 0.04298mm <sup>3</sup> /mm <sup>2</sup>
Vmc	= 0µm <sup>3</sup> /mm <sup>2</sup>
Vvc	= 0µm <sup>3</sup> /mm <sup>2</sup>
Vvv	= 0µm <sup>3</sup> /mm <sup>2</sup>
[mr1 = 10% mr2 = 20%]	
A	= 0.20mm <sup>2</sup>

Sample roughness data

NOTE: When clicking the "Surface Roughness" button, the data is also copied to the text clipboard.

NOTE: When clicking the "Surface Roughness" button, the data is also copied to the text

clipboard.

### 18.5.1.1 Abbot Firestone

By pressing 'Shift' simultaneously clicking the "Roughness" button, the Abbot Firestone curve will be shown.

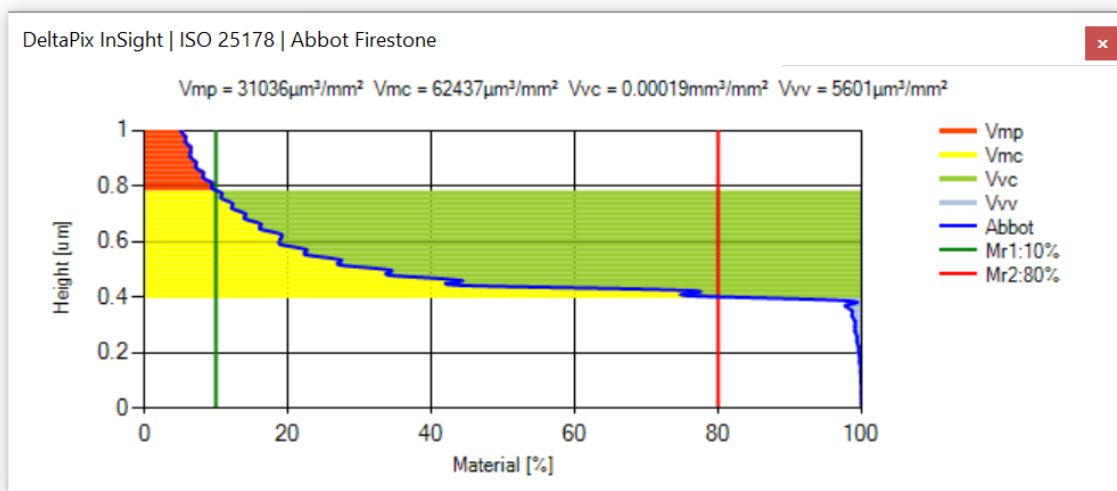
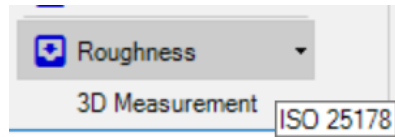

Example of Abbot Firestone curve

The Abbott-Firestone curve or bearing area curve (BAC) describes the surface texture of an object.

The curve can be found from a profile trace by drawing lines parallel to the datum and measuring the fraction of the line which lies within the profile.

Mathematically it is the cumulative probability density function of the surface profile's height and can be calculated by integrating the profile trace.

## 18.6 2D View

The 2D view offers a few options.

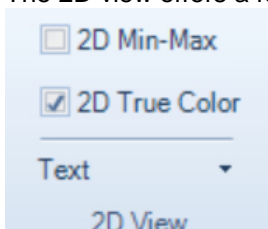

**2D Min-Max**

The 2D profile data is an average of the values inside region.

The display of min/max adds two curves to the 2D profile - the minimum and the maximum values used for the average calculation.

**2D True Color**

The 2D profile can be displayed as a plain line curve.

Alternatively, the 2D profile can be displayed using its real color, as shown on the 3D surface plot.

**Texts**

Header and footer texts can be added.

Annotations can be added by right clicking on a position on the 2D profile.

The callout will contain XYZ-information and the text in the 'Callout Text' text-box.

By mouse pointing the 3D line chart, the XYZ data is shown.

To add custom text to an annotation box, first select the annotation by clicking it with a mouse button. When selected, the color will change. Then type the text in the textbox.

## 18.7 2D Measurement

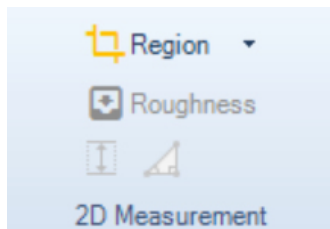

Region

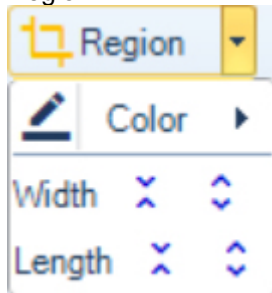

The wall color can be changed to enhance visibility.

The narrow/widen buttons can be used to adjust the region.

- i | Note: that if both top- and bottom-level is set to 0, then an automatic scaling will be done.

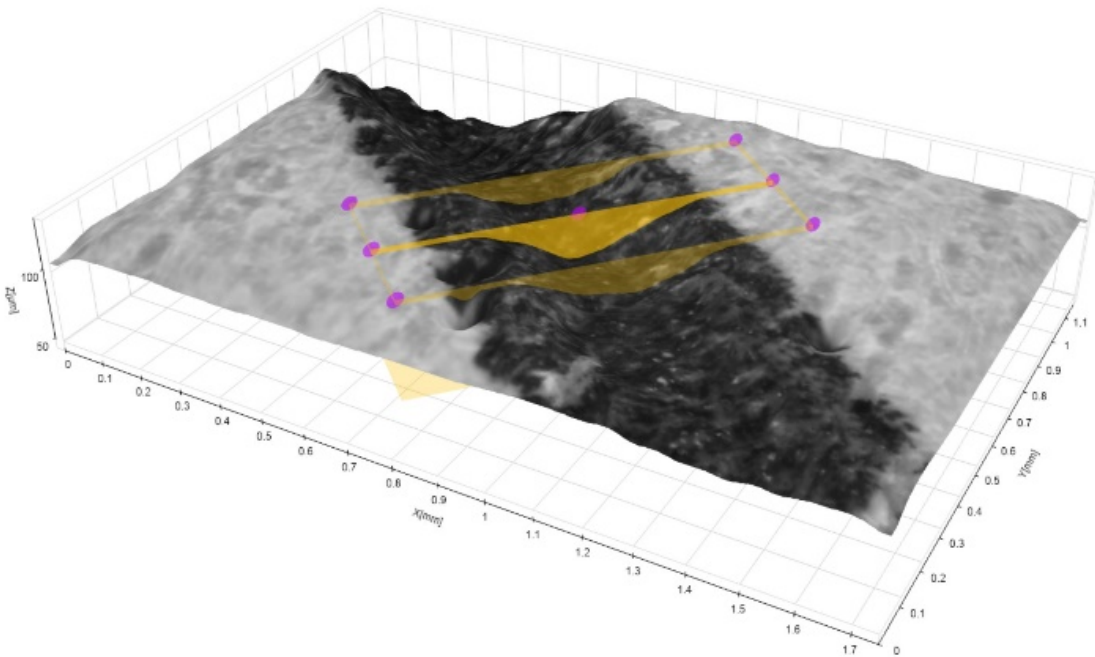

The best way to move a region is by mouse dragging the control bubbles. The control bubbles automatically show up when the mouse is moved within the 3D chart. The bubble color is always a 'complementary' color to the region color.

- The 4 corner points control the width and length of the region.
- The 2 midpoints control the length and angle of the region.
- The center point controls the overall position.

#### Mouse wheel control

Optionally the 2D region can be modified by the mouse wheel + a modifier key:

- Wall X position: Mouse Wheel + Shift
- Wall Y position: Mouse Wheel
- Wall Length: Mouse Wheel + Ctrl + Alt
- Wall Separation: Mouse Wheel + Ctrl
- Wall Angle: Mouse Wheel + Alt

If the walls will extend beyond the 3D curve, then they will be truncated.

### 18.7.1 2D Roughness

The Surface Roughness implements a subset of ISO 4287

Clicking the Roughness button will enable live update of roughness data when moving the region.

The parameters are associated to a 2D profile - data shown in a panel in the lower right corner.

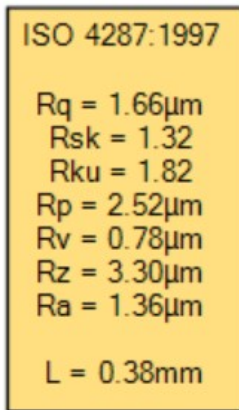

Sample 2D roughness data

### 18.7.2 2D Profile Measurements

Measurements can be done on the 2D profile.

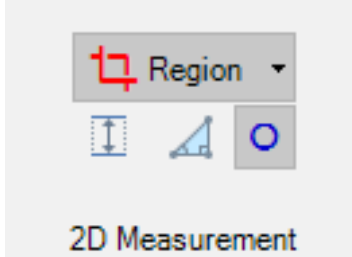

The 2D profile measurements can be exported into a report, please refer to the reporting section.

#### Height

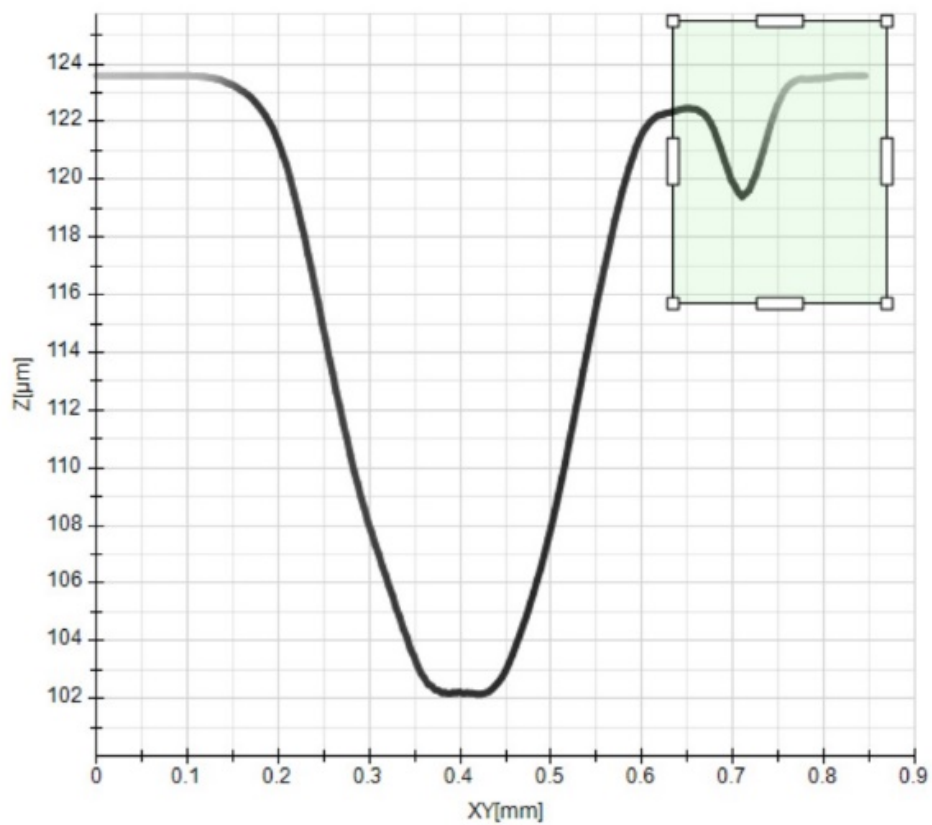

$$\Delta Z = 4.2 \mu\text{m}$$

The region can be dragged by mouse.  
The height difference is shown.

#### Angle

The two regions can be dragged by mouse.  
The angles relative to horizontal is shown.

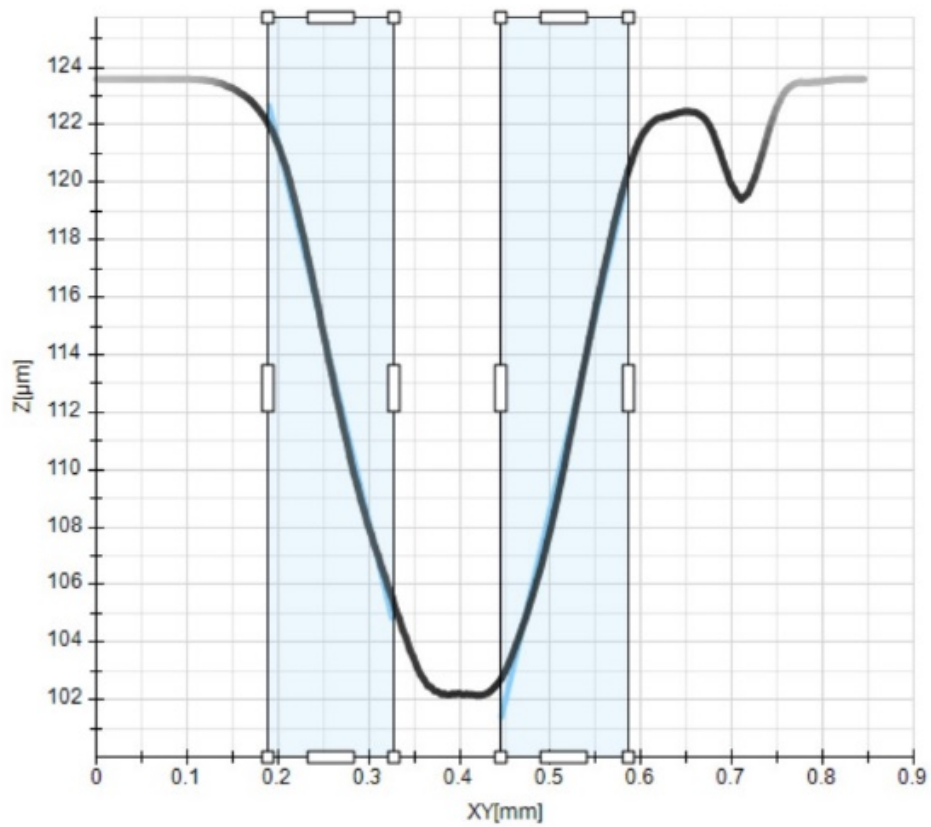

$$\angle -7.50^\circ - 7.69^\circ = 164.81^\circ$$

**Circle fit**

The region can be dragged by mouse.

The best circle fit of XY data within the region is shown.



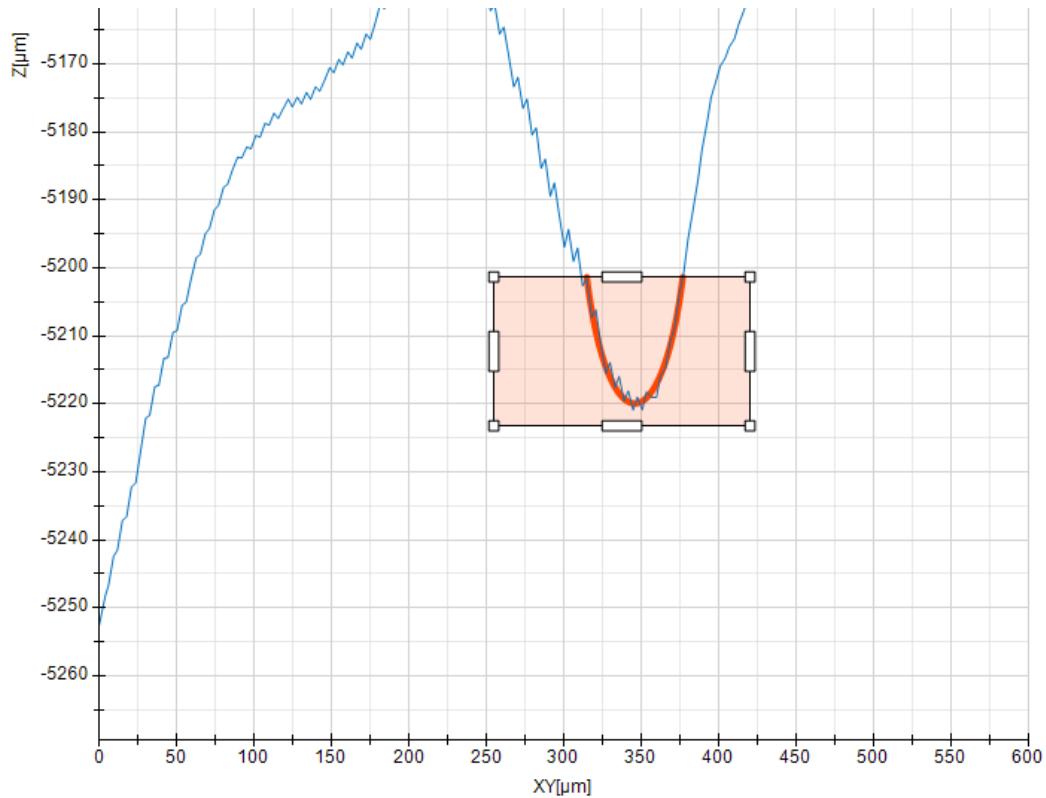

**R = 35.1 $\mu\text{m}$**

## 18.8 Reporting

### Reporting

A report can be generated in Excel format. This allows for further processing in the spreadsheet. The reporting uses an Excel template, defining the layout of the report. Image, measurement results and other information is placed in the spreadsheet by identifying tags.

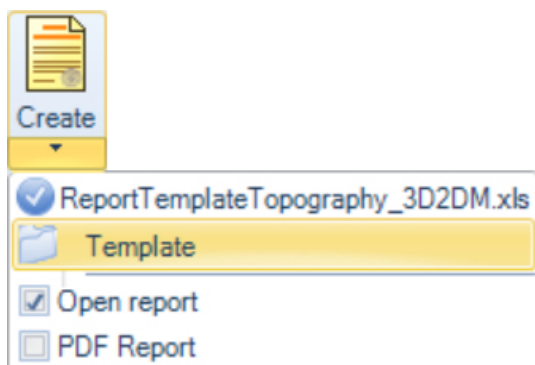

To make distribution very easy and flexible, a report can be published as PDF.

### 18.8.1 Template

A template must be defined, click the Template button to navigate to a template. After a template has been defined, simply click the Excel report button.

Valid tags for 3D roughness data are:

- %IMGS% defines the upper-left corner of image.
- %IMGE% defines the lower-right corner of image.
- %MEAS% defines column for measurement results.
- %UNIT% defines column for measurement units.
- %COL% makes a color marker in the color of the annotations text color.

Valid tags for 2D roughness data are:

- %IMGS2% defines the upper-left corner of image.
- %IMGE2% defines the lower-right corner of image.
- %MEAS2% defines column for measurement results.
- %UNIT2% defines column for measurement units.
- %COL2% makes a color marker in the color of the annotations text color.

Valid tags for 2D measurement data are:

- %IMGS% defines the upper-left corner of image.
- %IMGE% defines the lower-right corner of image.
- %MEAS% defines column for measurement results.
- %UNIT% defines column for measurement units.
- %COL% makes a color marker in the color of the annotations text color.

General tags are:

- %DATE% defines date.
- %TIME% defines time.
- %CAMERAMODEL% defines camera model.
- %PICTUREDPI% defines the image DPI.

## 19 Video recording [from v6.2.9]

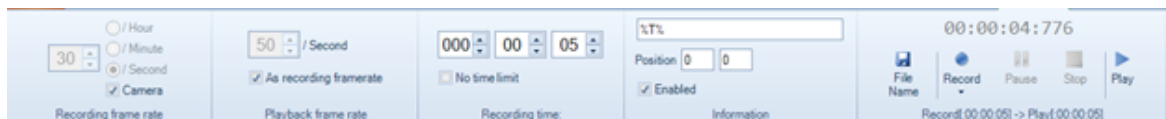

The video recorder allows for real time recording or lapse time recording. The recording- and the playback-frame rate can be set independently.

Optionally an overlay text can be specified, this can contain actual recording- and playback time.

**NOTE: THE OVERLAY TEXT IS CURRENTLY UTF-8 WHICH MEANS THAT SPECIAL CHARACTERS WILL IS NOT SUPPORTED.  
THE HERSHEY FONT USED ONLY HAS A LIMITED SUBSET OF ASCII.  
IT WON'T SHOW ACCENTS, CIRCUMFLEX OR ANY "SPECIAL" CHARACTERS LIKE THAT.  
SPECIAL CHARACTERS ARE CONVERTED TO NEAREST EQUIVALENT.**

## 19.1 Recording frame rate

The recording frame rate can be set to anything fixed from 1 frame-per-hour to 50 frames-per-second.

Alternatively, the actual camera frame rate can be selected.

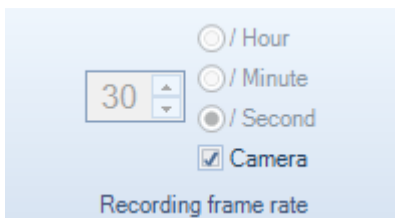

Panel for setting the recording frame rate.

Maximum frame rate

The recording frame rate can never be higher than the actual camera frame rate.

The actual camera frame rate can be read in the camera panel.

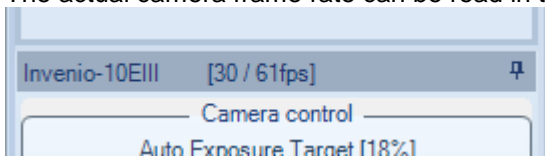

In this example the actual camera frame rate is 61fps, but the display frame rate is limited to 30fps.

## 19.2 Playback frame rate

The play frame rate can be set in the range from 1 – 100 frames-per-second.

Alternatively, it can be locked to the recording frame rate.

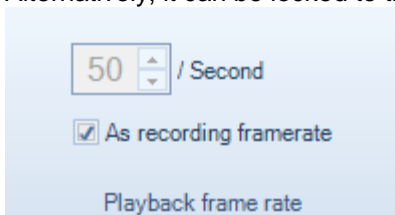

Panel for setting the recording frame rate.

## 19.3 Recording time

The recording time can be set anywhere in the range from 0h:0m:1s to 999h:58m:59s.

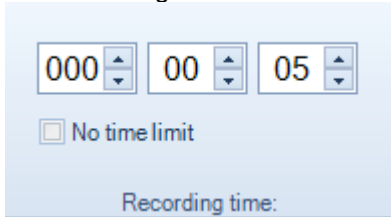

Panel for setting the recording time.

The “No time limit” check box enables endless recording, which will require a manual stop recording

## 19.4 Information

An information string can optionally be embedded into the video

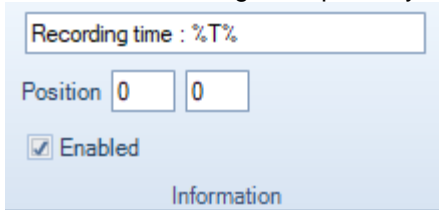

Panel for setting the optional embedded information.

The above example “Recording time : %T%” string will embed something like “Recording time : 00:01:23” as the %T% tag will be replaced by the recording time.

- %d% will insert actual date (MM:DD;YY).
- %t% will insert actual time (HH:MM:SS).
- %T% will insert recording time (HH:MM:SS), starting from 00:00:00
- %P% will insert playback time (HH:MM:SS), starting from 00:00:00

Example: "Date:%d% Time:%t% Rec:%T% Play:%P%"

will show up like: "Date:07/09/20 Time:08:33:58 Rec:00:00:15 Play:00:00:01"

The position is in pixel coordinates, (0.0) is top-left corner.

## 19.5 Recording

First a file name must be assigned to the video.  
Then the recording is started using the “Record” button

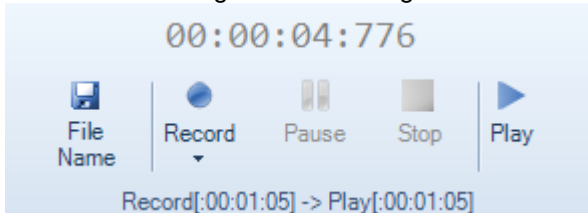

Panel for controlling the recording.

The recording can be paused at any time.  
The recording can be stopped at any time.

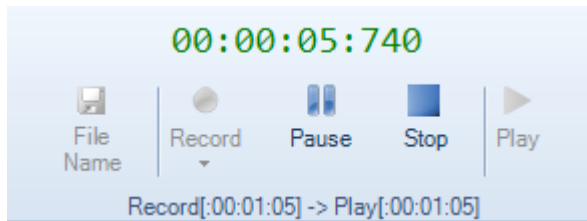

An ongoing recording is indicated by a green time string showing the recording time. This will turn orange when the recording is paused.

The Play button will play a video using the standard video player.  
If possible, the recording time and the play time is show in the bottom line. The recording time and play time may be different when recording and play frame rate differs.

### **Pause preview while recording**

When recording at high frame rate, it may be necessary to save some computational resources by pausing the preview. This is done by the record drop down check box.

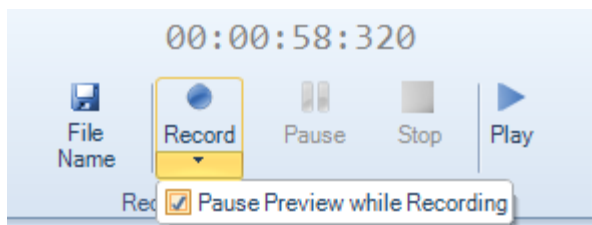

Setting the pause preview.

### **Other ways to save resources**

Instead of completely pausing the preview, the preview frame rate can be reduced.

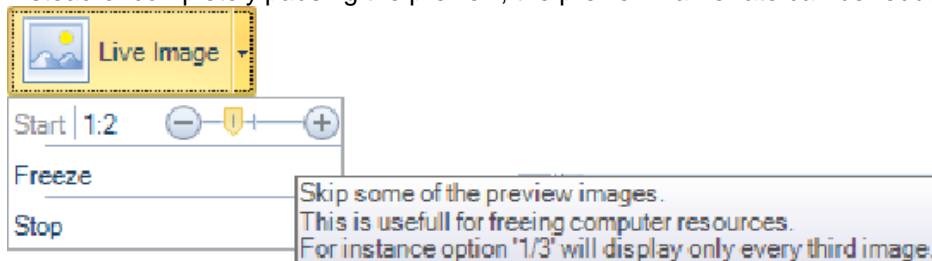

## 20 Shortcuts and special Keys

Many functions can be activated using keyboard shortcuts.

Function	Shortcut
Close all images	Ctrl-Shift-C
Capture Image	F1 Ctrl-Shift-I (hotkey)

Close live preview	Shift and click X
Save CSV file (or append measurement data)	F12
Bold	Ctrl-B
Italic	Ctrl-I
Underline	Ctrl-U
Paste	Ctrl-V
Delete	Del
Copy	Ctrl-C
Insert calibrated grid	Ctrl-G
Open XYZ control panel	Ctrl-F12
Manual Extended Exposure	F5
Automatic Extended Exposure	Alt-F5
Insert Scale Bar	F8
Manual Extended Focus	F6
Automatic Extended Focus	Alt-F6
Automatic Extended Exposure and Focus	Shift-Alt-F6
Force Image Red	Ctrl-Shift-R
Force Image Green	Ctrl-Shift-G
Force Image Blue	Ctrl-Shift-B
Open Image	Ctrl-O
Print Image	Ctrl-P
Remap Intensity	Ctrl-Alt-R
Open Optics Editor	Shift-Alt-O
Pause preview	Alt-F1
Full Screen	F11 (hotkey)
Toggle monitor. Toggles between all attached monitors.	Alt-F11
Open Control Panel	Shift-Alt-L

Capture flat field reference image (Shading correction)	Shift-Alt-S
Enable flat field correction (Shading correction)	Ctrl-Shift-S
About	Shift-Alt-A
Undo (not all operations supported)	Ctrl-Z
Save Image As	Ctrl-S
Undo processing	Ctrl-Shift-Z
Toggle auto exposure on/off	Alt-F2 Ctrl-Shift-J
Point white balance	Alt-F9
Global white balance	Alt-F10
Default white balance	Alt-F11
Create a new measurement, same type as the most recently used.	Spacebar
Toggle tabbed - MDI View	Ctrl-Shift-T
Tile Vertical (when in MDI view)	Ctrl-Shift-V
Tile Horizontal (when in MDI view)	Ctrl-Shift-H
Arrange (when in MDI view)	Ctrl-Shift-A
Launch 'Quick System Setup' tool	Ctrl-Shift-W
Manual Topography	Ctrl-Shift-A
Save All (Gem alt)	Alt-Shift-G
Select Easy save directory	Ctrl-E
Auto Stitch start	Alt-Shift-Y
XYZ table start acquisition	Alt-Shift-X

## 20.1 Special start-up modifier keys

In some cases it can be necessary to launch the DeltaPix InSight in special or safe mode.

Function	Key	Comment
Reduce the the frame rate to ½x	Alt	Press immediately after program launch -

default		pressing before, may open the programs Properties dialog.  Keep the key down until program has completely started.
Disable all motor control	Shift	Keep the key down until program has completely started.
Avoid workspace load	Ctrl-Alt	Press immediately after program launch - pressing before, may open the programs Properties dialog.  Keep the key down until program has completely started.
Launch a debug window	Ctrl	Keep the key down until program has completely started.

## 20.2 Special shut-down modifier keys

Function	Key	Comment
Avoid workspace save	Ctrl-Alt	Keep the key down until program has completely stopped.

## 20.3 Motor speed modifier keys

In some cases it is convenient to run the XYZ motors at another speed than the pre-programmed speed, or the speed calculated from the Magnification or DOF.

By activating modifier keys as listed in the table, the speed can be increased or decreased.

Modifier Key			
Ctrl	Alt	Shift	Action
			No modification - relies on settings (Speed, Magnification, DOF)
		a	2x speed



	a		1/2x speed
	a	a	1/4x speed
a			Full speed as set in motor configuration
a		a	4x speed
a	a		1/8x speed
a	a	a	8x speed

## 21 FAQ - Frequently Asked Questions

### 21.1 Software freeze checklist

Our general trouble shooting list for freezing software or non-responding cameras is:

1. USB cable must be high quality, and as short as possible, not more than 2mtr. USB cable problems during time can show up as black images, non-responding cameras or other ways that not at first sight look like USB cable problems. Try another short good quality cable.
2. Do not connect the camera via an external USB hub.
3. Some computer build-in USB ports operate via an internal USB hub. Often, but not always, the ports on the front are using an internal USB hub. Try another port.
4. Some new computers try to save power by managing the power, powering down a USB port may cause the attached hardware to malfunction. See section 'Fix an Annoying Windows USB Power Problem' on how to avoid this.
5. Carefully avoid exposure to static electricity. Static discharge may cause the camera to freeze or malfunction.
6. Disable the internet connectivity. DeltaPix InSight may look for software updates, but your company security can block this, and cause the software to 'hang'. As a test, disable the internet connection on the computer (disable Wireless, or remove cable). The Internet connectivity can also be disabled within the InSight software.
7. The software will not run on a 'Guest' account – avoid this.
8. The USB plug of the camera may become 'loose' and unstable during time, especially on systems with frequent cable plug/unplug.
9. If the camera is a USB3 camera, try it on a USB2 port.
10. Is the camera a InvenioIII camera - like e.g. Invenio 5SIII or Invenio 6EIII , then check that the green LED is NOT blinking.
11. Check the communication to external devices. For serial COM port communication, the

driver version is essential

## 21.2 Installing Prior software

The installed Prior software should be 8.5.2.x64 or 8.5.4.x64

This is available from [www.prior.com](http://www.prior.com) or from [www.deltapix.dk](http://www.deltapix.dk)

## 21.3 Understanding magnification

Magnification is a matter of definition.

Normally we think of magnification on a digital microscope as the ratio of the shown size on the PC monitor compared to the actual physical size.

So if the object has a dimension of 1mm and displays on the monitor as 12.3cm, then the magnification is 123x (So also the monitor size and resolution is to be considered).

In short we calculate the magnification as:

$$M_t = M_o \times M_d \times P_{Sm} / P_{Sc};$$

Where:

- $M_t$  is the total magnification
- $M_o$  is the optical magnification
- $M_d$  is the digital magnification (like if you zoom using the mouse wheel...)
- $P_{Sm}$  is the pixel size on the monitor (You need to set you monitor size in the DeltaPix InSight control panel, resolution can be read by the software).
- $P_{Sc}$  is the pixel size in the camera.

Please consult the manual, section "Show Absolute or Relative magnification".

## 21.4 Get rid of old Invenio 3S/5S drivers

If you are updating from DpxViewPro (discontinued 2009) to DeltaPix InSight then it may be slightly difficult to install the new drivers:

To get rid of the old driver for the Invenio 3S do the following:

1. Detach the camera Invenio 3S
2. Goto the C:\windows\inf directory
3. Delete files with name X18cu.inf and X18cu.pnf
4. Goto the C:\windows\system32\drivers
5. Delete files with name X18cu.sys
6. Attach the camera Invenio 3S
7. Make the device manager look for a new driver.



## 21.5 Install driver for For InvenioIIIeb Cameras

Installation of (1st generation only) Invenio-5SIII and Invenio-10SIII device drivers

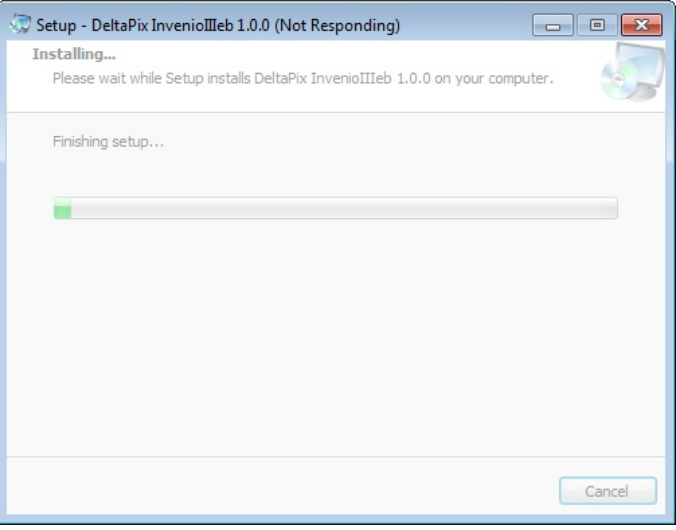
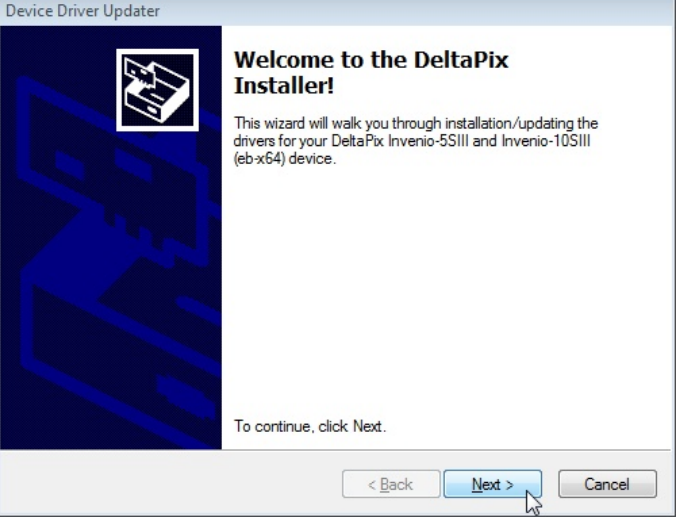
- Do not attach the camera yet.
- Install the DeltaPix InSight
- Follow this procedure to manually install device drivers for the Invenio-5SIII and Invenio-10SIII cameras.

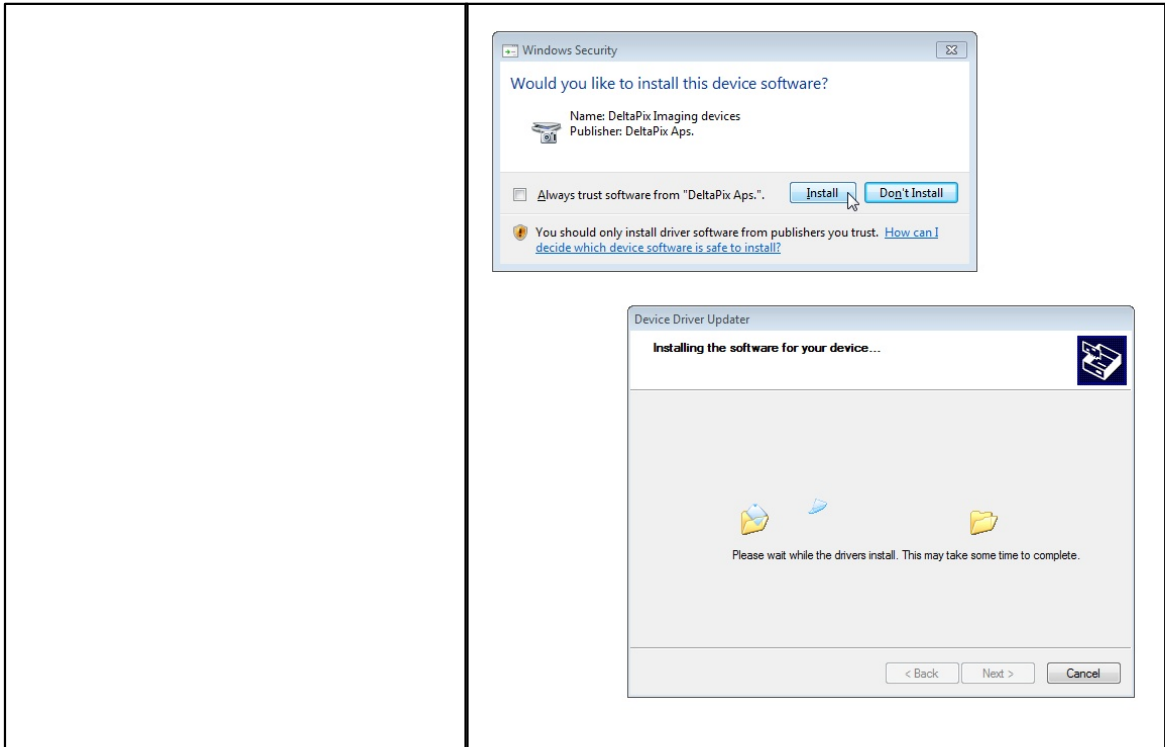
<p>Launch the Setup_InvenioIIIeb_a.b.c installer Note: a.b.c is the version number of the installation program, and may change.</p>	
<p>Click next to start the installation.</p>	
<p>Click 'Install' to install the device software.</p>	

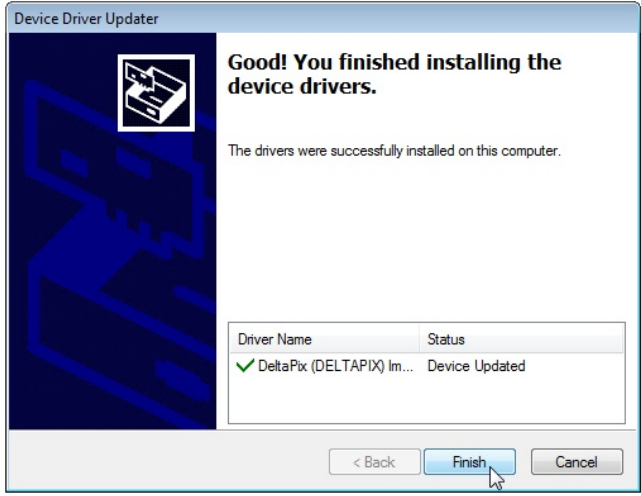

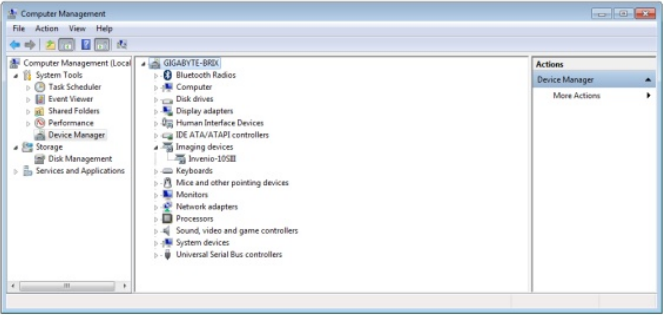
<p>Click 'Finish'.</p>	
<p>Click 'Finish'.</p> <p>Now attach the camera to a vacant USB3 (or optionally a USB2) port.</p> <p>Is is NOT recommended to connect via a USB hub.</p> <p>Let the camera install - may take a few minutttes.</p>	
<p>The camera should now appear in the Device Manager as Invenio-5SIII or Invenio-10SIII</p>	

If the camera does not install correctly, please contact support@deltapix.dk

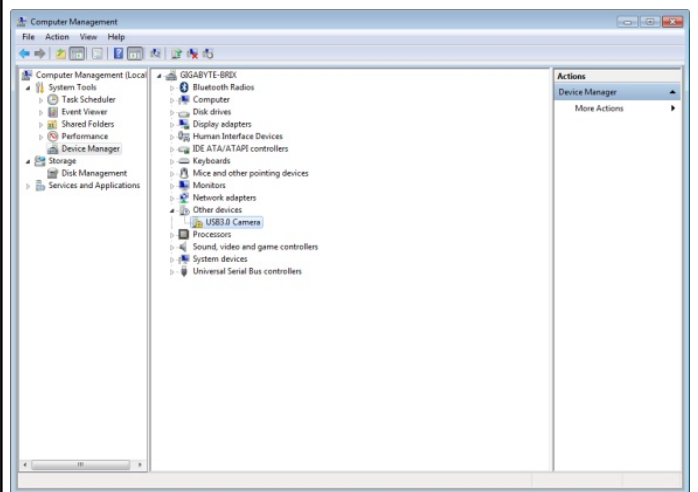

## 21.6 Disable Internet connectivity

If your company network is very restrictive - it may be necessary to disable the internet connectivity to avoid a freezing program

To disable all internet activity, make sure that the 'Check for news' and 'Check for software updates' check boxes are unchecked.

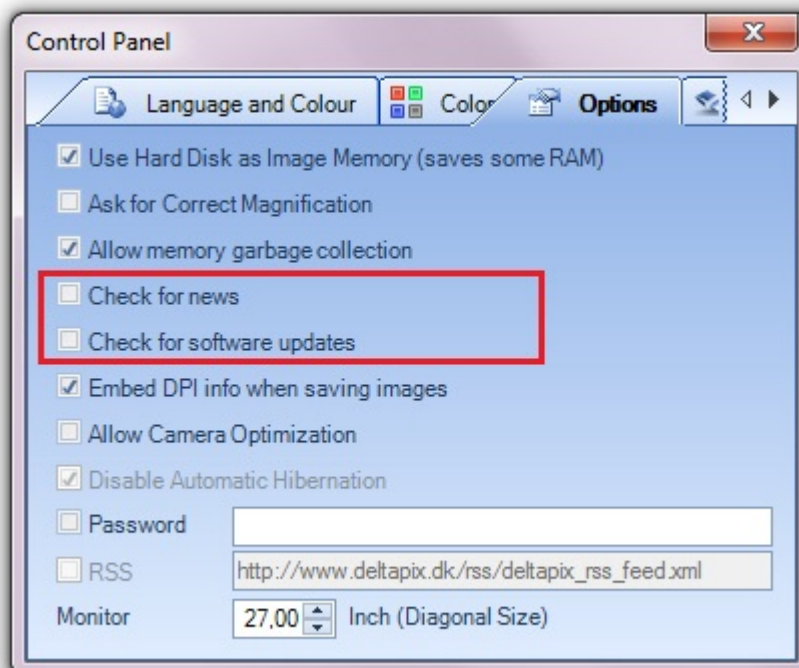

## 21.7 Frame rate drops

The camera preview display may use a major part of the computers resources. DeltaPix InSight contains several mechanisms to balance the frame rate to release computing resources.

This may in some rare cases lead to a (annoying) reduced frame rate.



The frame rate can be forced to maximum by right clicking the "Live Image" button.

## 21.8 Fix an Annoying Windows USB Power Problem

Since XP, the Windows operating system has come with a feature called USB Selective Suspend. This allows the system to turn off specific USB ports without affecting the other USB ports. This is supposed to save power by closing down ports that are only used intermittently.

However, sometimes the port does not get turned back on when it is needed. On a desktop or other system where this type of power saving is not crucial, consider disabling this feature if you are experiencing USB connection problems.

The feature can be disabled or re-enabled in Control Panel.

1. Open Control Panel
2. Go to: Hardware and Sound->Power Options
3. Find your preferred power plan and click "Change plan settings"
4. Click "Change advanced power settings"
5. A dialog box similar to the example in the graphic will open
6. Find the entry "USB settings" and expand it
7. Expand the entry "USB selective suspend setting"
8. Use the drop-down menu to disable or re-enable the setting as shown in the graphic below
9. Click "OK"

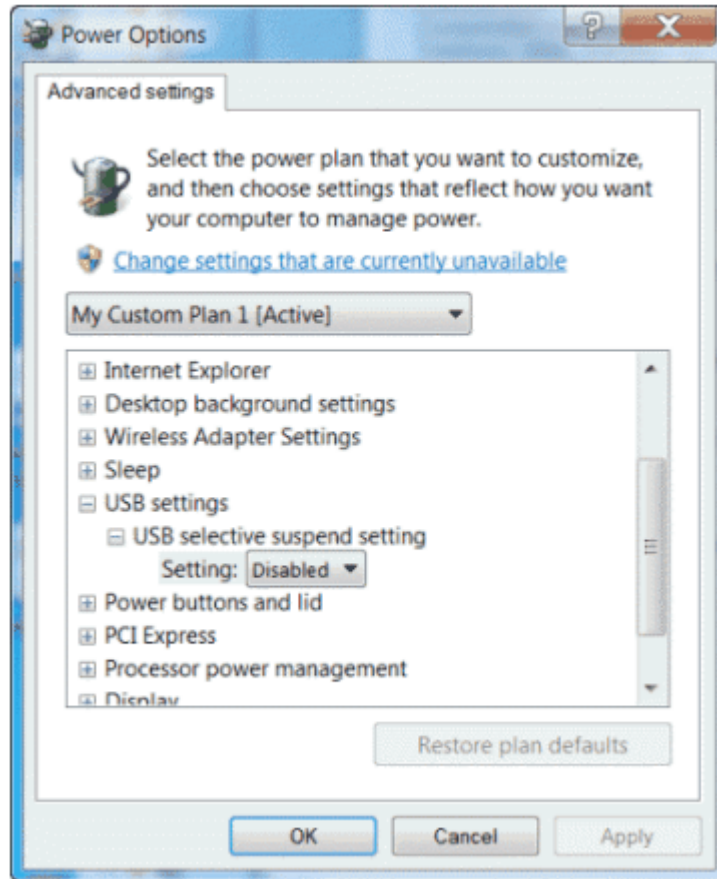

In Windows 8.1, the problem of a USB port being turned off can be even worse. See this MSDN post for details. Incidentally, the problem of an unresponsive USB port can also often be fixed by turning the computer off and back on.

Thanks to: <http://www.techsupportalert.com/content/how-fix-annoying-windows-usb-problem.htm>

## 21.9 ATEN USB to RS232 converter driver

**Incorrect driver versions may cause the program to freeze or crash.**

Always make sure that you use updated drivers for your converter.

For Windows 8/8.1 (64/32), 7 (64/32), Vista (64/32), 2003, and XP the following driver should be recommended:

CP210x USB to UART Bridge Driver v6.6.1 - October 24, 2013

This should look something like this in the device manager.



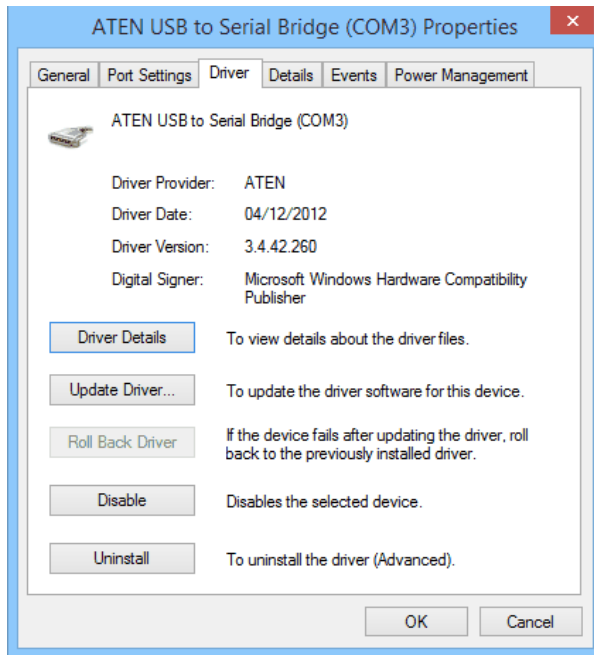

## 21.10 USB Cables

USB ports and connectors are often color-coded to distinguish their different functions and USB versions.

These colors are not part of the USB specification and can vary between manufacturers; for example, USB 3.0 specification mandates appropriate color-coding while it only recommends blue inserts for Standard-A USB 3.0 connectors and plugs.

USB 1.x	White
USB 2.0	Black, sometimes white
USB 3.0	Blue
Sleep-and-charge	Yellow or red

## 21.11 Graphics performance

By selecting a Power Plan for your computer you may affect the graphics performance.

It is not recommended to use the 'Power saver' plan, as this may disable the GPU., and slow down camera frame rate and 3D performance.

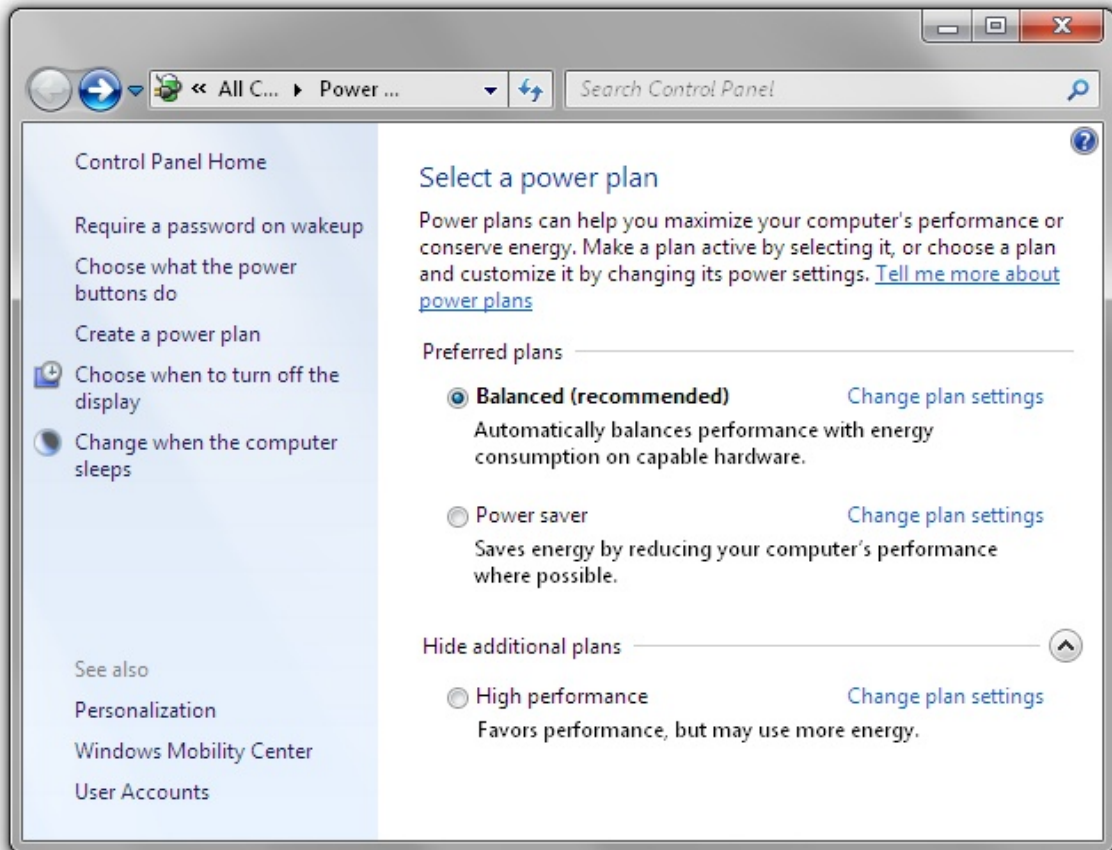

## 21.12 A generic error occurred in GDI+

This error is a common one and also very tricky. The error itself is not very descriptive.

Permission problems is the common cause, but there have been some cases where the permissions are fine and it still happens.

If this error is caused by permissions then there are two possible scenarios:

- The account the process is running as does not have permission to write images to the target directory. Fix your permissions.
- The target directory does not exist. Create it first.

It may be difficult to tell exactly which directory or permission is invalid.

## 22 Appendix

## 22.1 Backup - Restore - Cloning

### Creating a backup

When a system is fully configured, it is recommended to do a backup of the complete settings.

This backup can be used for:

- To restore the settings on the same computer – in case of emergency.
- To clone the settings to another computer or another user on the same computer.

Click  
'Backup Configuration'

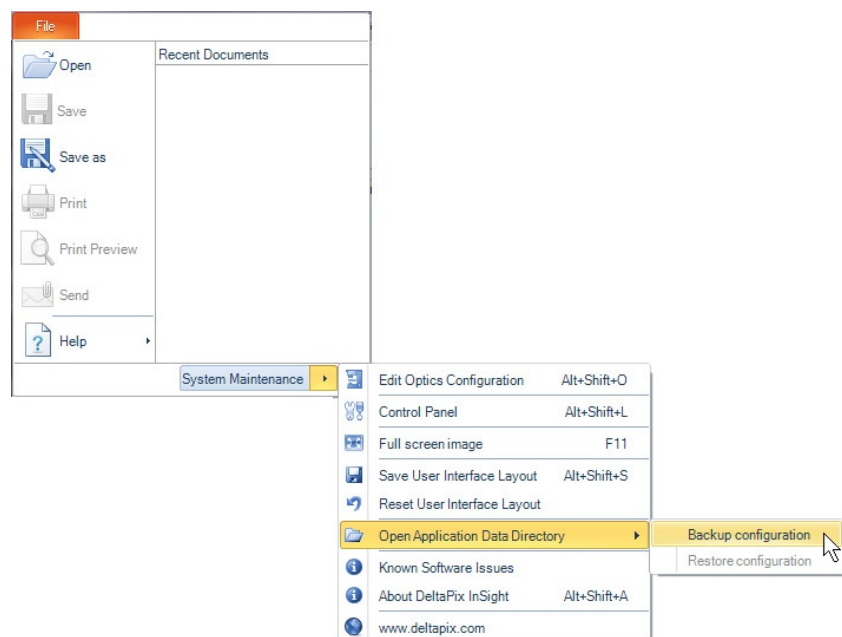

Select a folder for the backup.

It is preferable to use an empty folder, eventually make a new folder.

Click OK

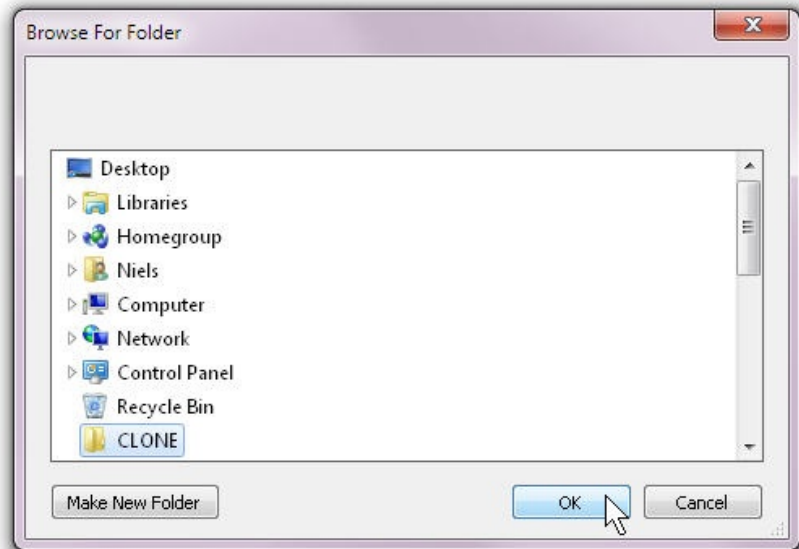

Files will be copied, and a message pops up when complete. *Note: while copying files, the program might seem unresponsive, so please be patient while the copying is taking place.*

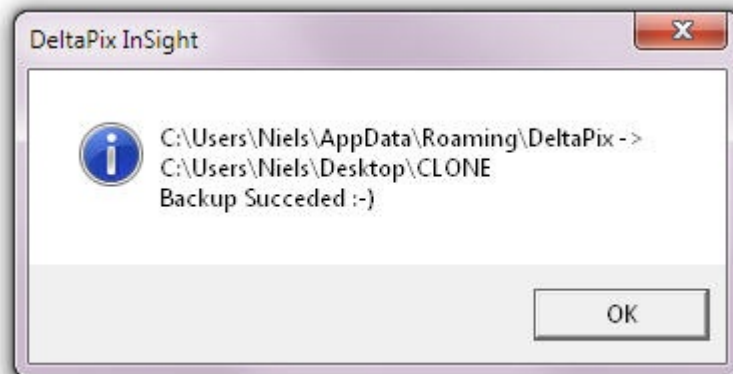

## Restore Settings – or cloning to another computer.

To clone the settings, use the 'Quick System Setup' wizard. This can be launched at any time from the control panel, or by the Ctrl-Alt-W keys.

The Clone option is the 2<sup>nd</sup> step in the 'Quick System Setup' wizard.

Click 'Clone Now'.

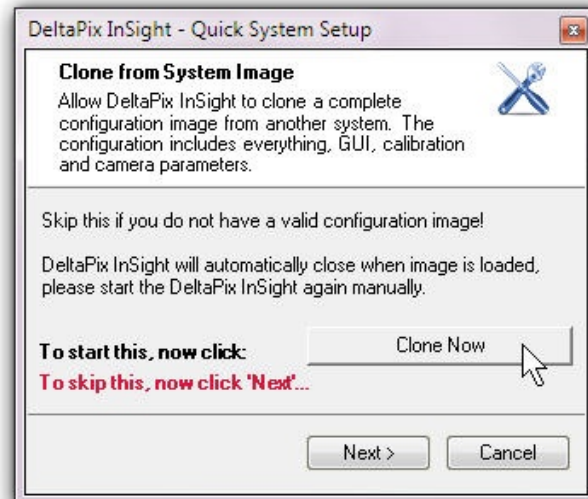

Click 'Yes' if you are sure that you want to do the cloning.

NOTE: There is no possible undo to a cloning!

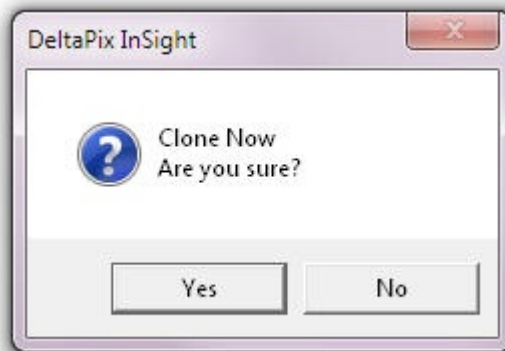

Select the folder containing the files to be used for cloning.

All necessary files were generated from a 'Backup Configuration', as described elsewhere.

Click OK, to start the cloning.

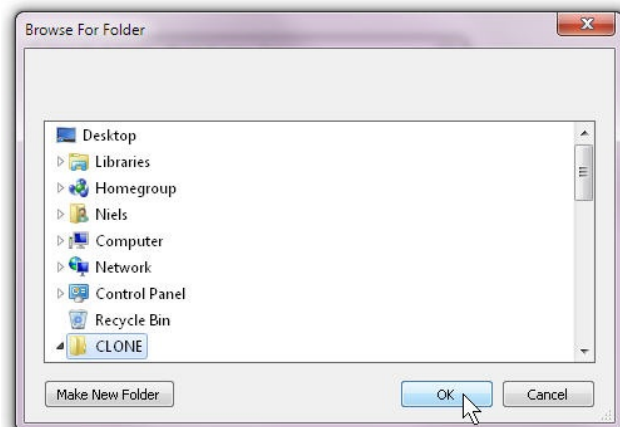

Files will be copied, and a message pops up when complete.

The program will close, and will need to be launched again manually.

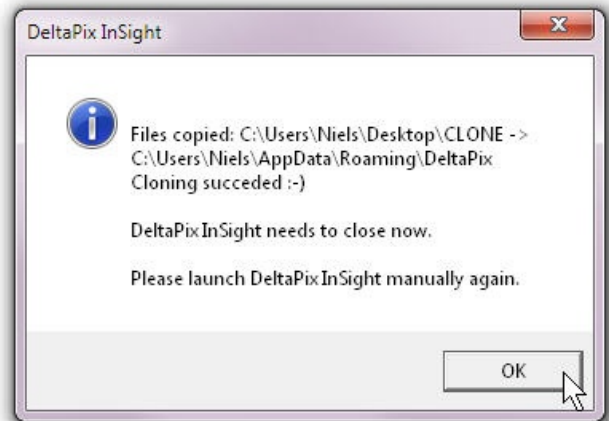

## 22.2 External Drive for Settings

Program settings can be automatically stored on a specific drive, e.g. a removable USB drive. This feature makes system distribution easy, and eliminates the need for cloning.

The drive is identified by its volume label. The volume label must be: DELTAPIX\_SETTINGS

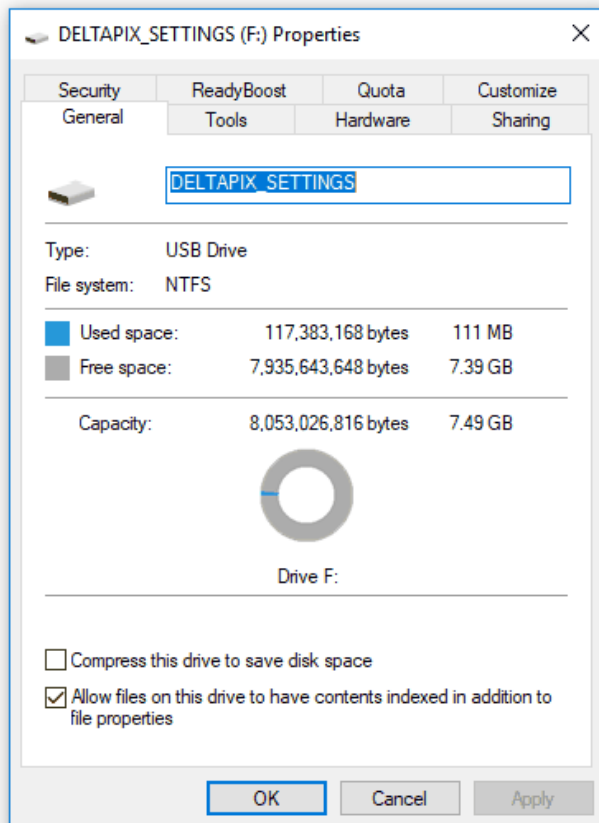

The drive should be formatted as NTFS.

**There are several ways to put the settings onto the external drive:**

1. Insert the DELTAPIX\_SETTINGS drive before configuring the DeltaPix InSight
  - a. Settings will then automatically be stored on the drive when closing DeltaPix InSight
2. Insert the DELTAPIX\_SETTINGS drive after configuring the DeltaPix InSight - follow Method 1 or 2.

NOTE: The settings on the external drive are shared among all users.

## 22.2.1 Export Settings to External Settings Drive - Method 1

Enter topic text here. **Follow these steps carefully to export settings data to an external settings drive.**

- (1) Do NOT insert the external target drive yet!
- (2) Start DeltaPix InSight
- (3) Insert the external target drive, Make sure that the drive has volume label DELTAPIX\_SETTINGS.
- (4) Prepare copy process by clicking "Open Application Data Directory".

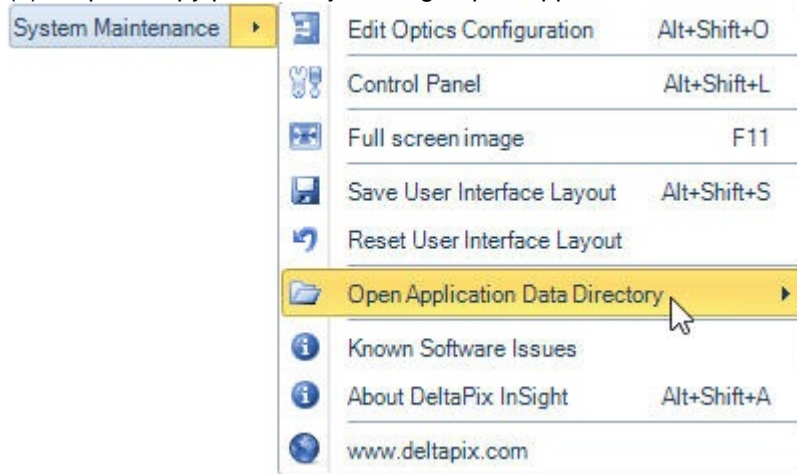

- (5) This will open the application data directory. Then:
  - Go one directory up - to the Roaming directory.
  - Select the DeltaPix directory.
  - Right click this directory
  - In the pop-up, select "Send to"
  - In next pop-up select DELTAPIX\_SETTINGS



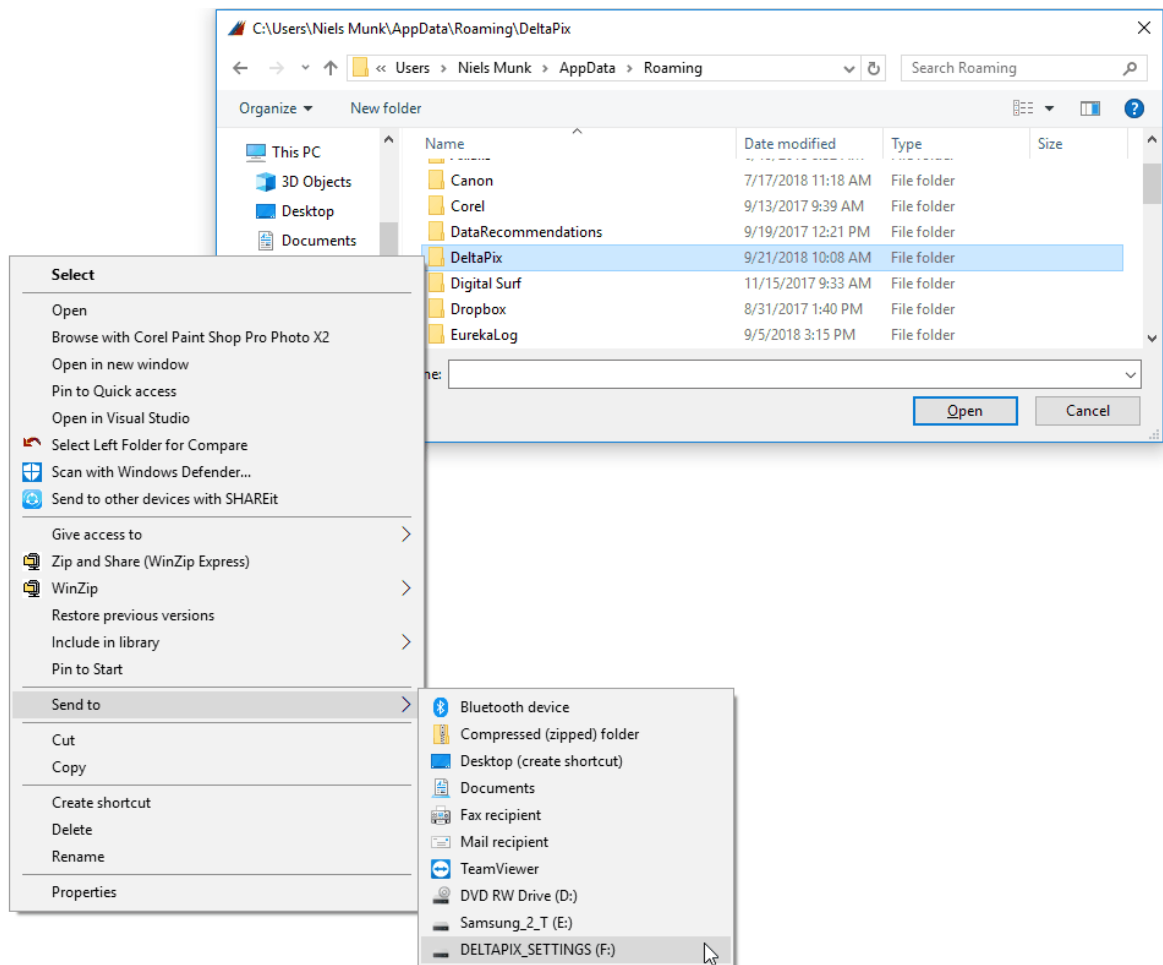

(7) The copy process normally takes a few seconds - have patience.

(8) Restart DeltaPix InSight - now the settings on the external drive will be used.

## 22.2.2 Export Settings to External Settings Drive - Method 2

**Follow these steps carefully to export settings data to an external settings drive.**

(1) Do NOT insert the external target drive yet!

(2) Start DeltaPix InSight

(3) Insert the external target drive, Make sure that the drive has volume label DELTAPIX\_SETTINGS.

(4) Prepare copy process by clicking "Create Clone Files".

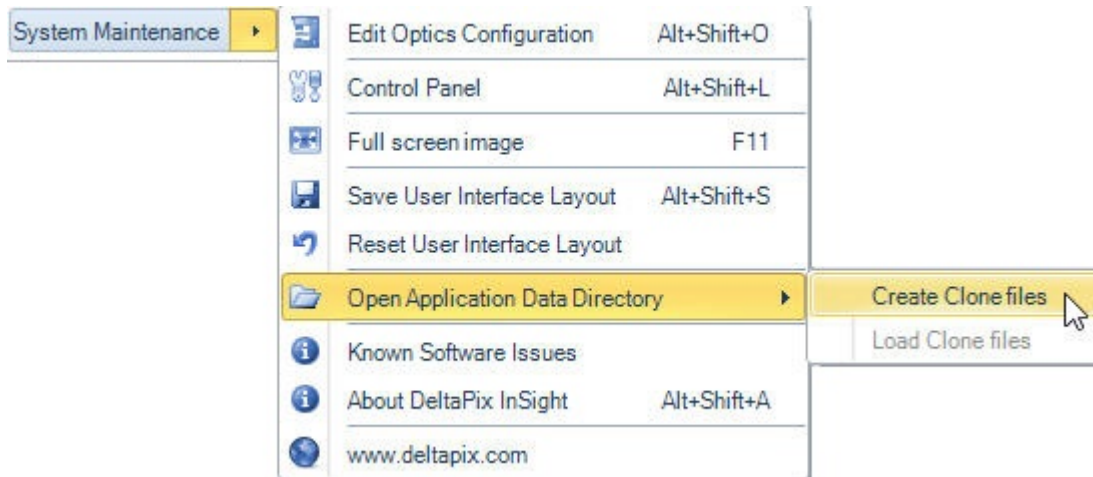

(5) Browse to the DELTAPIX\_SETTINGS drive.

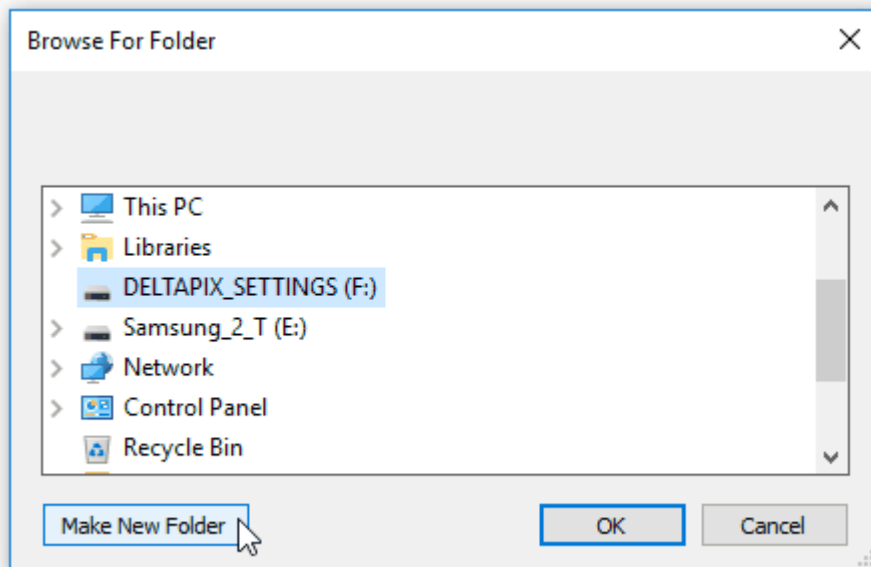

(6) Create a directory named DeltaPix - using the exact name is vital. Select the newly created directory. Click OK.

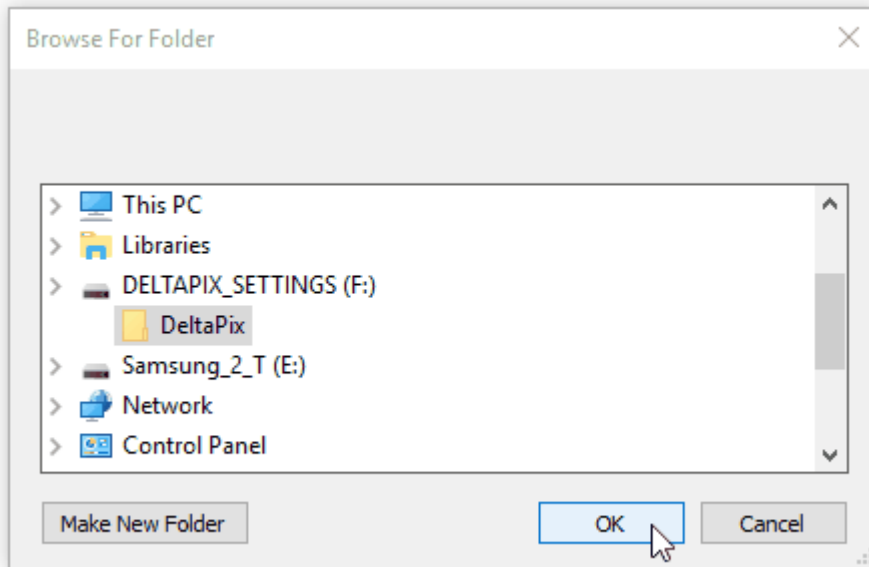

(7) The copy process normally takes a few seconds - have patience.

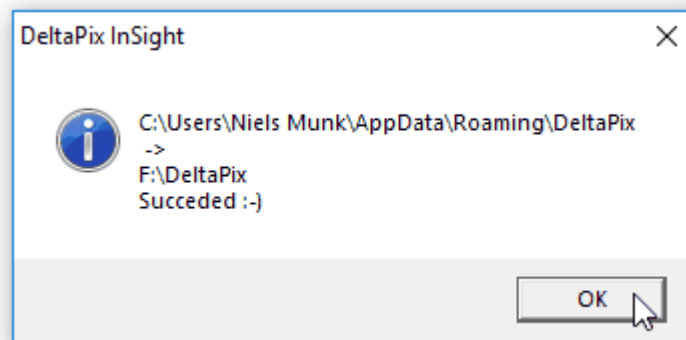

(8) Restart DeltaPix InSight - now the settings on the external drive will be used.

### 22.2.3 Import Settings from External Settings Drive

**Follow these steps carefully to import settings data from an external settings drive.**

- (1) Do NOT insert the external source drive yet!
- (2) Start DeltaPix InSight
- (3) Insert the external source drive,
- (4) If the "Quick System Setup" wizard does not pop-up automatically. The press the "Ctrl-Shift-W" keyboard combination.
- (5) Go to the Clone page, and click "Clone Now".

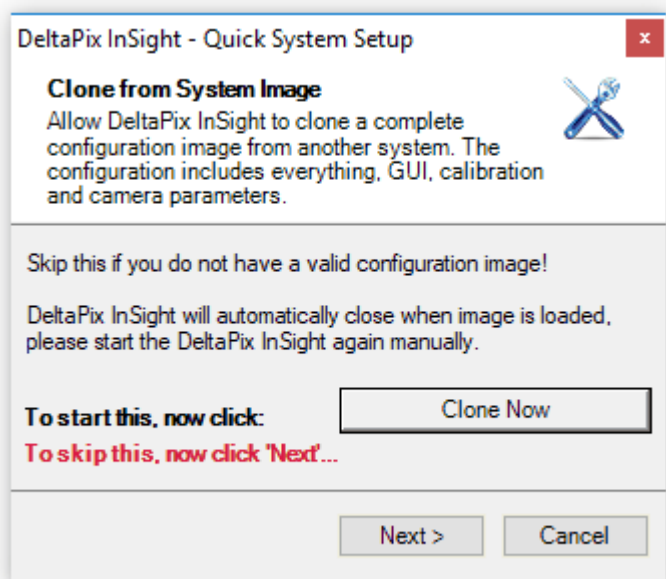

(6) Browse to the external source drive (which in this example is named DELTAPIX\_SETTINGS). Select the DeltaPix directory (which in this example is the parent directory for the settings). Click OK.

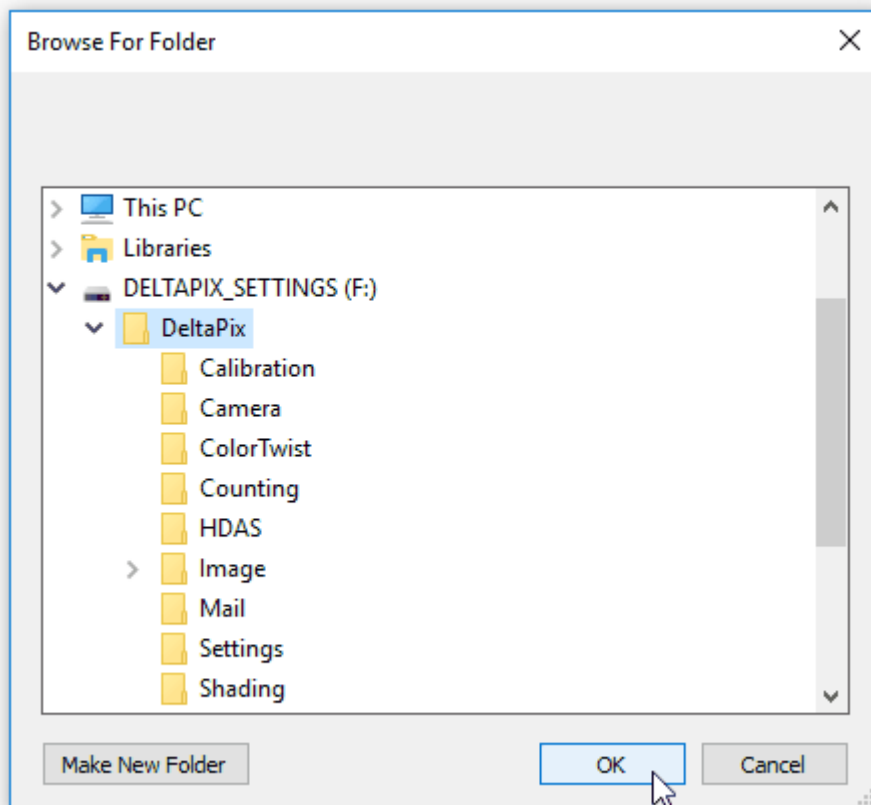

(7) After files are copied, a message box will pop-up. Click OK to close DeltaPix InSight

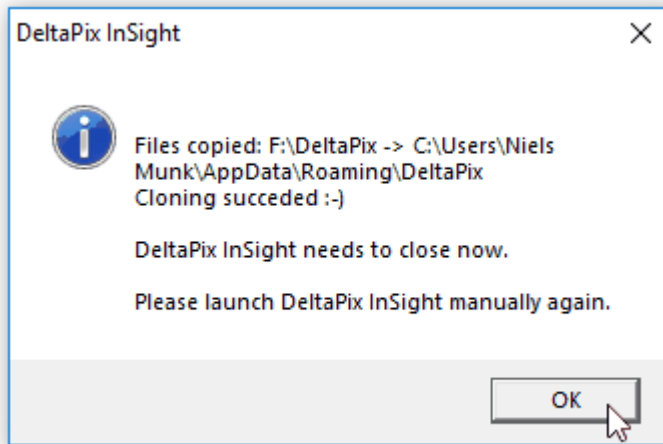

- (8) Remove the external source drive.
- (9) Start DeltaPix InSight - now the imported settings will be used.

## 22.3 Installing and connecting to Prior (OptiScanII)

### 22.3.1 Installation

The OptiScanII does not have a full USB implementation so there is very little advantage in using it.

Where no RS232 com port is available on the computer, we suggest using a USB to RS232 converter and then connecting to RS232 on the converter.

This is to our best knowledge only a problem in conjunction with the Prior OptiScanII, and does not apply to e.g. the ProScan series and the ES10Z.



Always consult the Prior documentation before installing Prior software.

### 22.3.2 64bit operating system

On a computer with a 64bit operating system

- Install the **32bit** version of the Prior software.
- If installing any drivers for the USB, install **64bit** drivers.

### 22.3.3 Prior OptiScanII Z-motor operation.

In case the Z-motor spins at a different (like much lower) speed than expected, it might be the steps/mm parameter that needs to be changed to a lower value – see below.

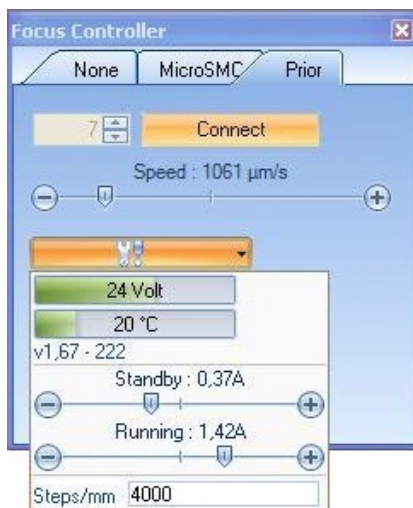

## 22.4 TWAIN

- A 32 bit TWAIN source is available for InvenioII cameras.
- A 32 and 64 bit TWAIN source is available for InvenioIII cameras.

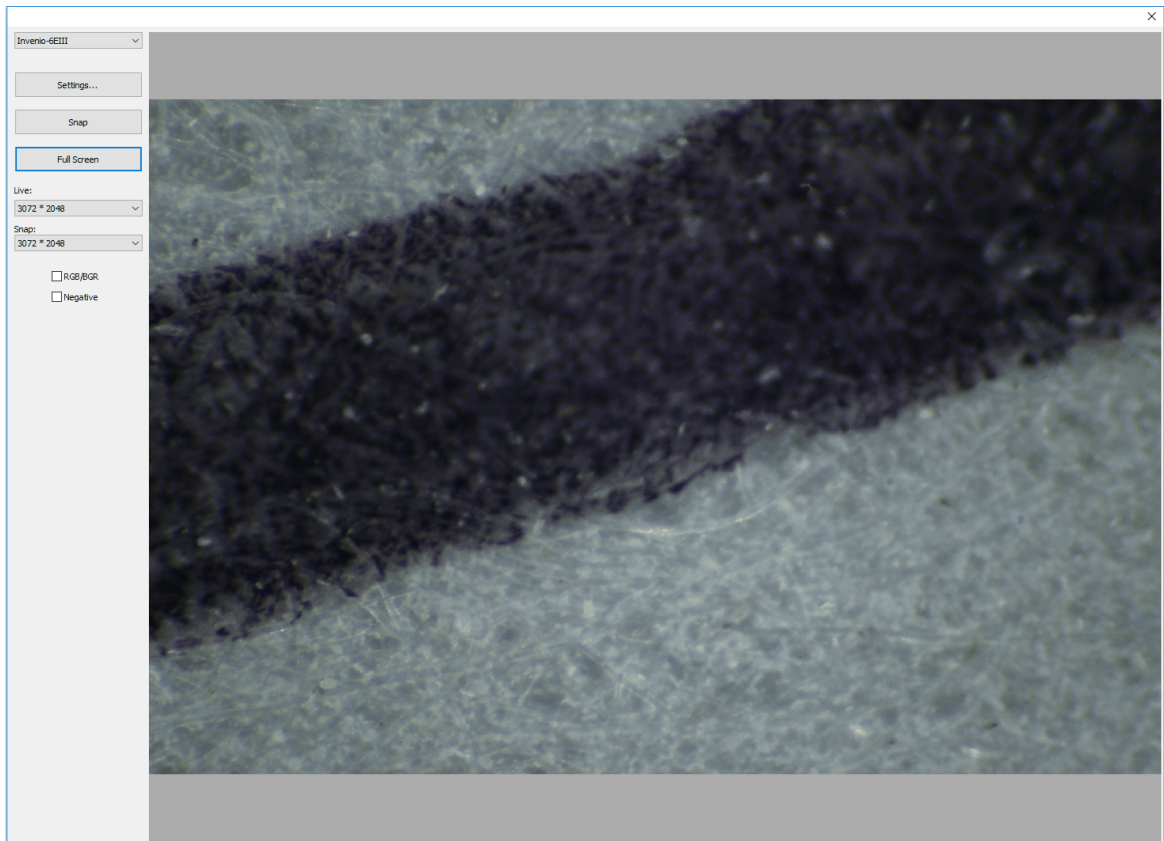

Example of TWAIN capture using an Invenio-6EIII camera.

## 22.5 DirectX (DirectShow)

DirectShow filters are available for the InvenioII and InvenioIII cameras.

Note: These filters are not installed by the default installer.

## 22.6 Matlab

A Matlab camera driver is available for the InvenioIII cameras.

Note: This driver is not installed by the default installer.

## 22.7 Installing and connecting to Zeiss MTB 2011

The Zeiss MTB2011 needs to be installed on your computer.

### Recommended steps for "DeltaPix InSight":

- Use a clean Windows 10 computer without other security software that Microsoft Defender.
- Use the MTB2011 recommended for the actual version of DeltaPix InSight
- Install the MTB2011 RDK
- Used the MTBConfig to autoconfigure the microscope.
- Make sure that you have a DeltaPix dongle that supports the Zeiss microscope options.
- Follow the instructions to calibrate and set-up the microscope in DeltaPix InSight.

### 22.7.1 Using another version of MTB2011 than the default MTB2011 version

#### The default MTB2011 version

The default MTB2011 version is shown in the interface panel.

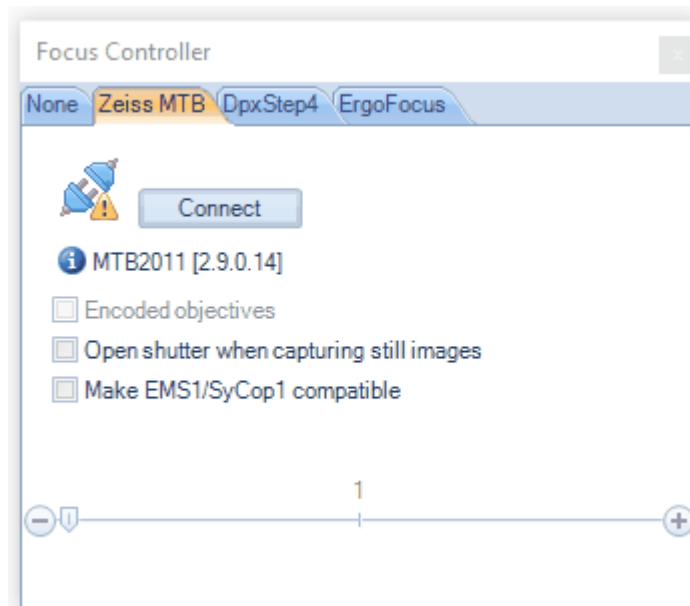

In the above panel, the MTB2011 v2.9.0.14 is the default version.

If you want to use another MTB2011 version (MTB2004 cannot be used!), a version redirection must be done.

NOTE1: The version redirection must be done every time the DeltaPix InSight is installed, as



---

the installation reverts to the default MTB2011 version.

NOTE2: The interface panel will still show the default MTB2011 version after a redirection has been done, it does not show the redirected version.

## Run the InSight\_RedirectMTB2011.exe redirection program

In the DeltaPix InSight installation directory run the InSight\_RedirectMTB2004.exe program as administrator -right click on the file; select 'Run as Administrator'.

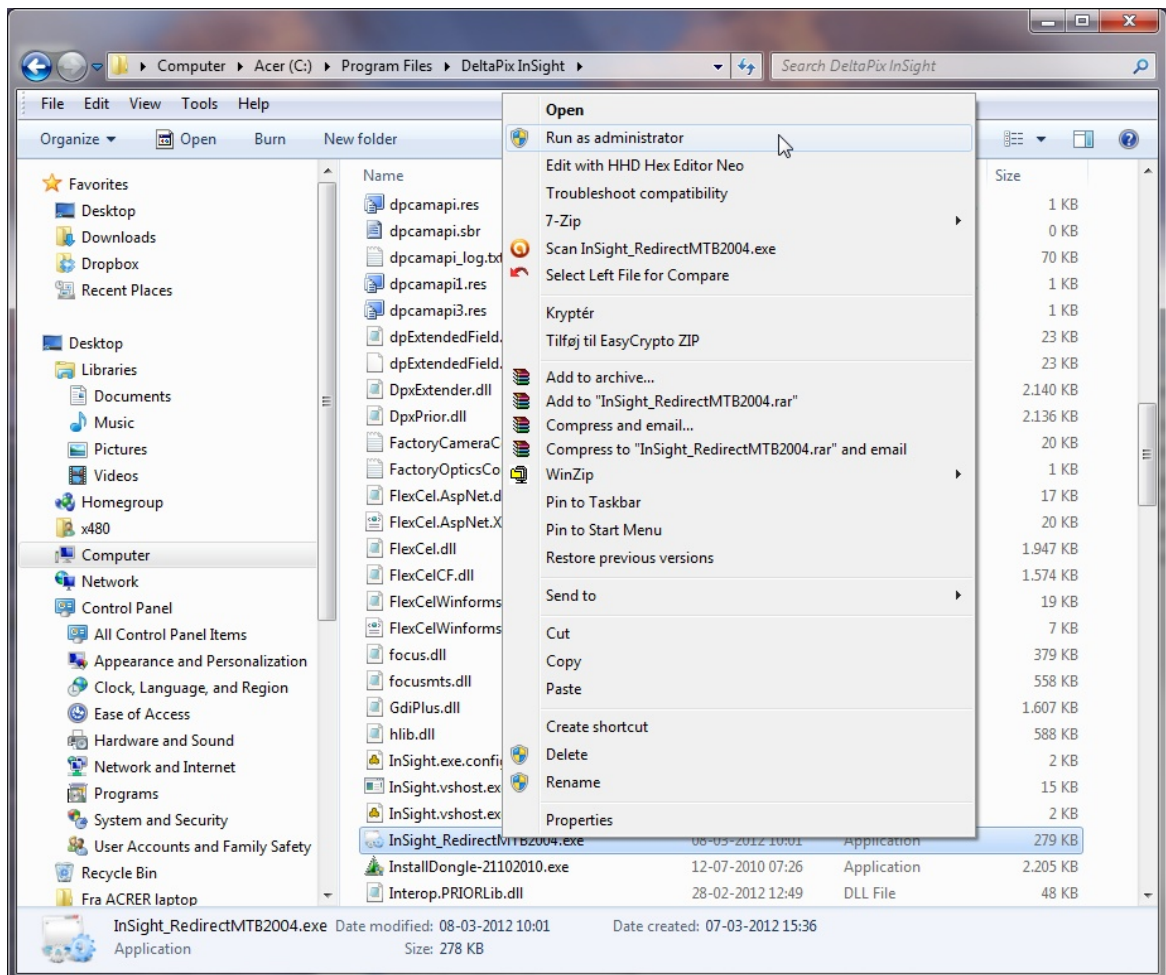

## Select the version of your MTB2011.

Select your version of MTB2011, by changing the green up-down text boxes. Then 'Save'.

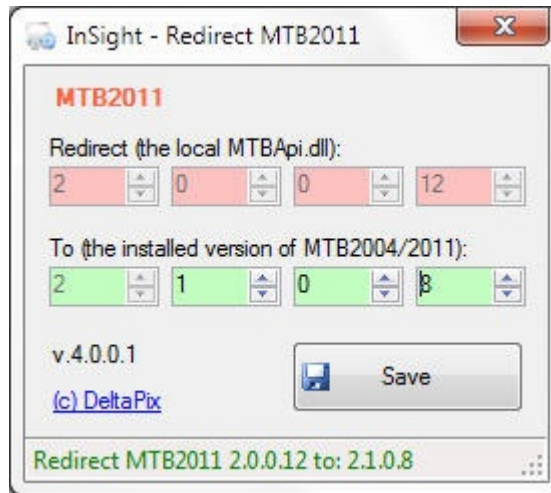

### 22.7.2 Optics Editor and calibration hints

(1) The MTBConfig of the objectives must be the same as in the Optics Editor!

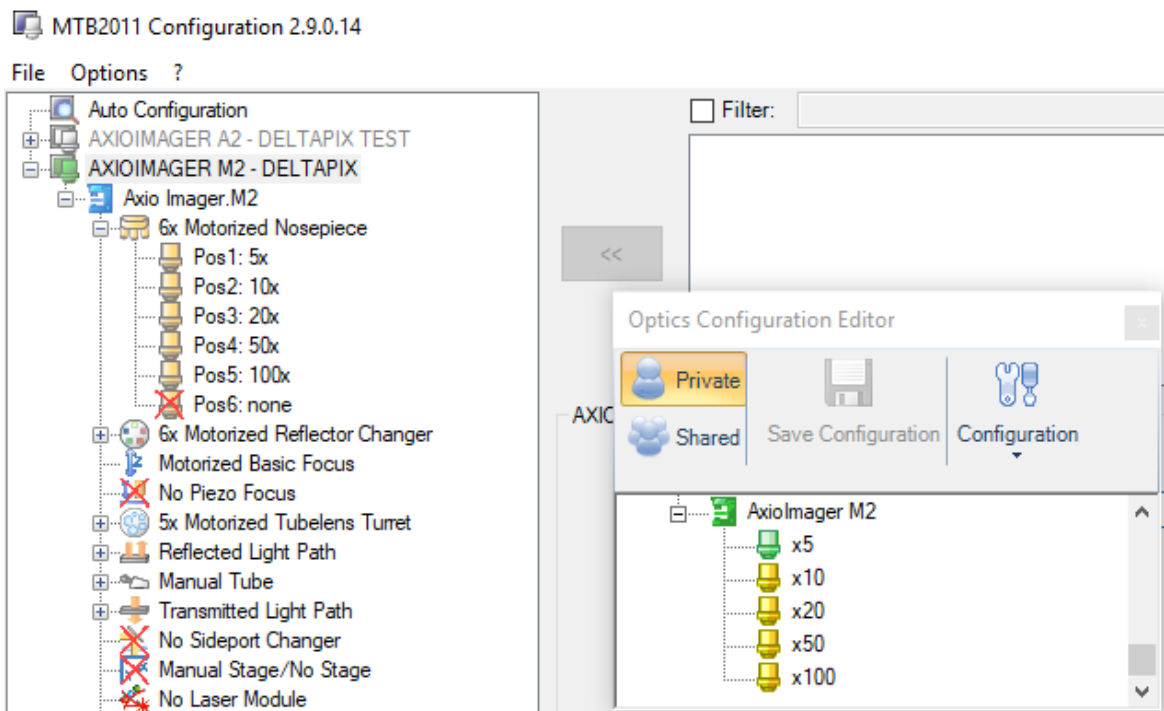

Example of a AxioImager M2 configuration. The x5 is calibrated and interpolated to the other objectives.

(2) The calibration must be done with a 1x Tubelens and a 1x Reflector magnification!

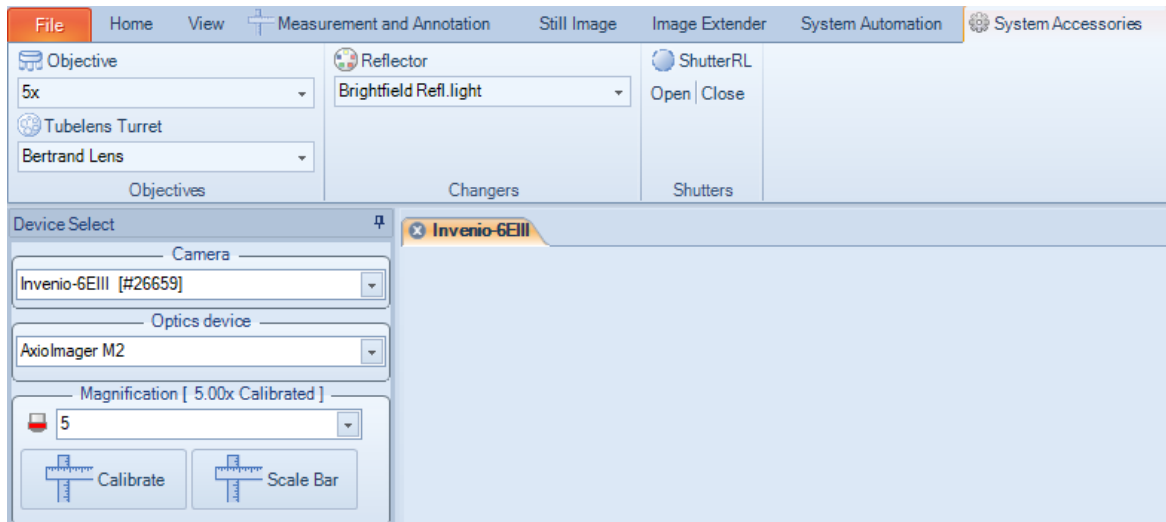

Example of a valid calibration setup. Tubelens is 1x and Reflector is 1x.

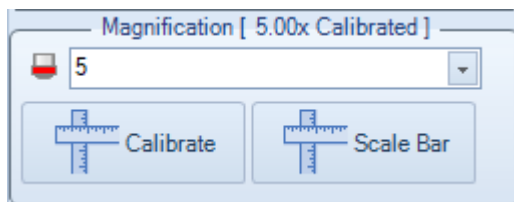

## 22.8 Märzhäuser TANGO

DeltaPix InSight can operate a Märzhäuser TANGO controller.

Install the Märzhäuser TANGO software as described by Märzhäuser. Before connecting, the appropriate COM port must be selected.

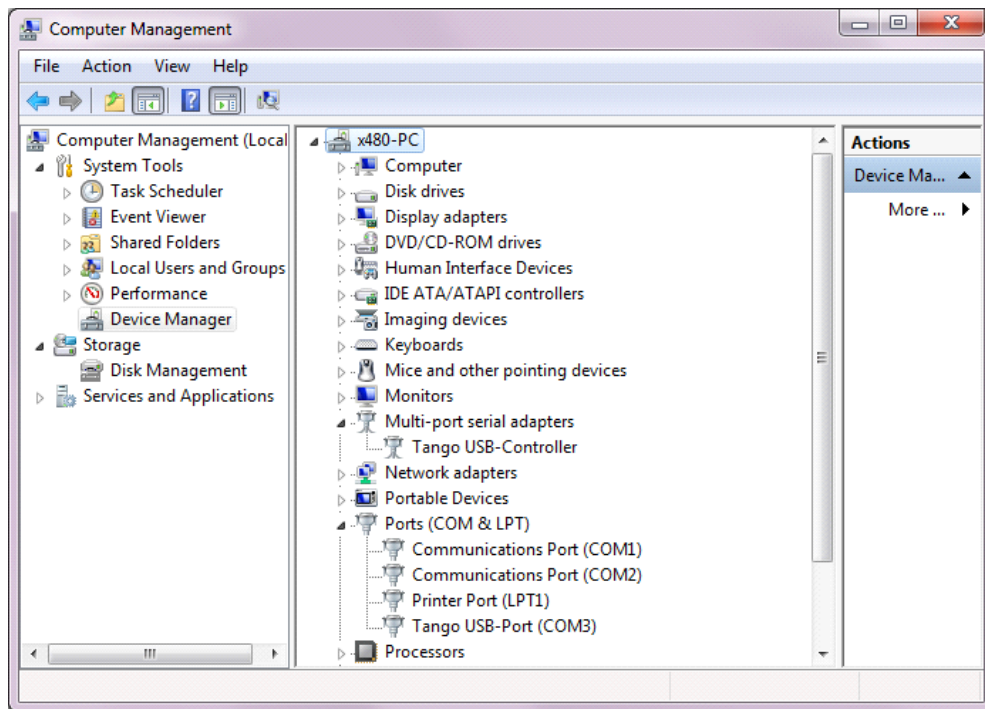

From the above 'Computer Management' panel, it can be seen that the Märzhauser TANGO is connected via COM3. Select the right COM port, and click the connect button.



Always consult the Märzhauser documentation before installing Prior software.

## 22.9 Mitutoyo MF - Communication Setup

Set up the microscope RS-232 communication to:

- Before DeltaPix InSight v6.1.18 : 9600, N, 8, 1, NoFlowCtrl .
- From DeltaPix InSight v6.1.18 : 9600, E, 7, 1 NoFlowCtrl (This is almost the default microscope setting)

See technical document 99MBA091A6 (31.05.2013) on how to configure the microscope.

- See page 1-11 on how to setup RS232 communication
- See page 1-13 on how to enter/exit setup

### F07 Microscope Communication Setup

- F07-1 = 9600 baud

- F07-2 = 7 databits
- F07-3 = Even parity
- F07-4 = 1 stopbit
- F07-5 = Flowcontrol (xon/xoff) = OFF
- F07-6 = Flowcontrol (hw) = OFF

### F03 Resolution setup

All axes, select the 0.1 : Minimum readout of 0.1 $\mu$ m/0.00001"

### RS232 Cable

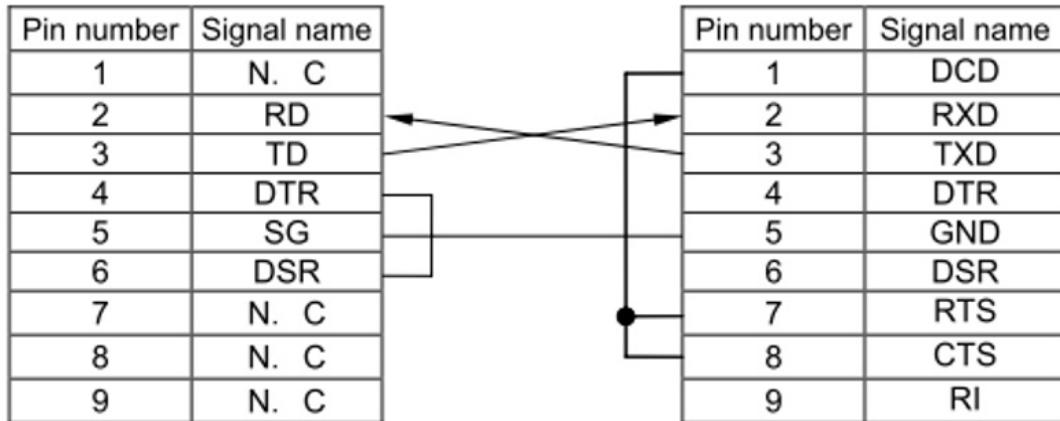

Optionally use a USB-RS232 converter in the PC end.

### Dataformat example

Query : "A"<cr><lf>

Response : "X +004.1880,Y +004.5870,Z +006.1523"<cr><lf>

will display:

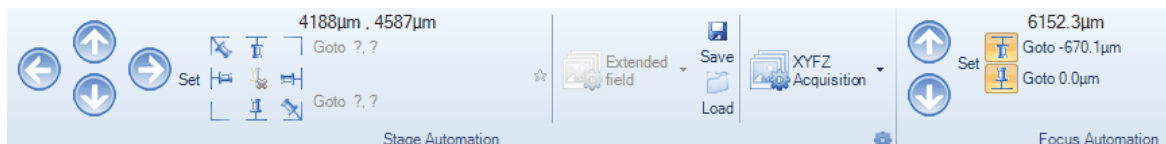

## 22.10 Custom Camera Configuration

The factory camera configuration can be overridden, to have customer specific camera properties.

This is done via a dedicated file "FactoryCameraCfg\_UsrDef.txt" that must reside in the Camera application data directory (something like "C:\Users\MyName\AppData\Roaming\DeltaPix\Camera").

This directory is easily opened by the "File | System Maintenance | Open Application Data Directory" button.

Placing the file there makes it part of the backup-clone mechanism.

---

To override e.g. the Invenio 6EIII - copy the file from the "FactoryCameraCfg\_InvenioIII.txt" to the "FactoryCameraCfg\_UsrDef.txt" and edit the parameters needed.

## 22.11 Artray ARTCAM-130XQE-WOM Camera

ARTCAM-130XQE-WOM is a NIR camera which adopts a 1280 x 1024.  
The cameras have a high sensitive spectral response from 400 nm to 1200 nm.

Attach the camera.

Install the camera driver from the CD

Browse to the driver location on the CD (also search sub directories).

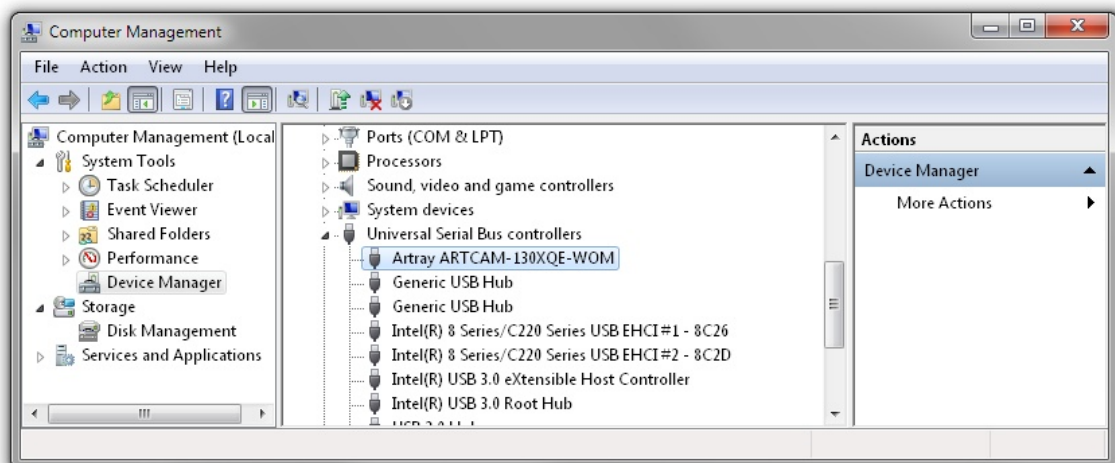
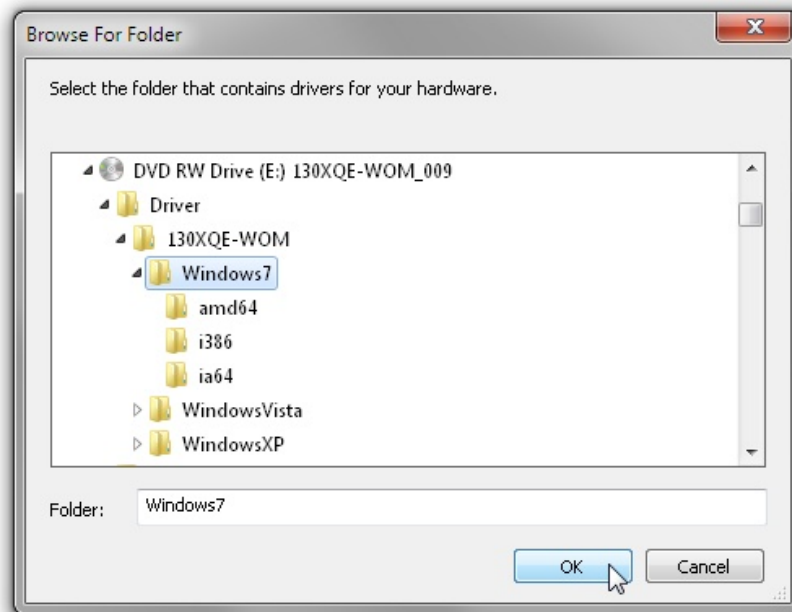

Note that the camera does not (as you would expect) appear under 'Imaging Devices', but under 'Universal Serial Bus controllers'.



## 22.12 Artray ARTCAM-990 SWIRTEC camera

ARTCAM-990 SWIRTEC is a camera which adopts a 1280 x 1024.  
The cameras have a high sensitive spectral response from 400 nm to 1700 nm.

### 22.12.1 Artray ARTCAM-990 SWIRTEC - Driver installation

Attach the camera.  
Install the camera driver from the CD

Browse to the driver location on the CD (also search sub directories).

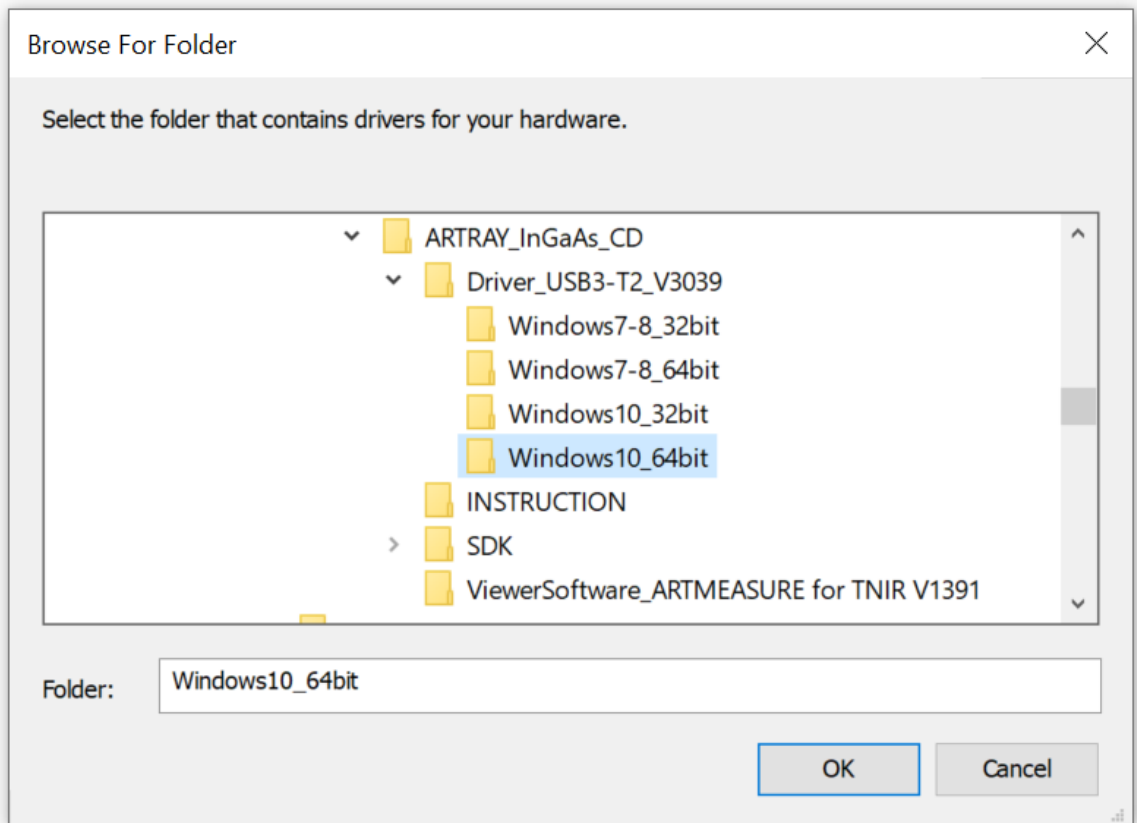

Select the Windows10\_64 bit driver.

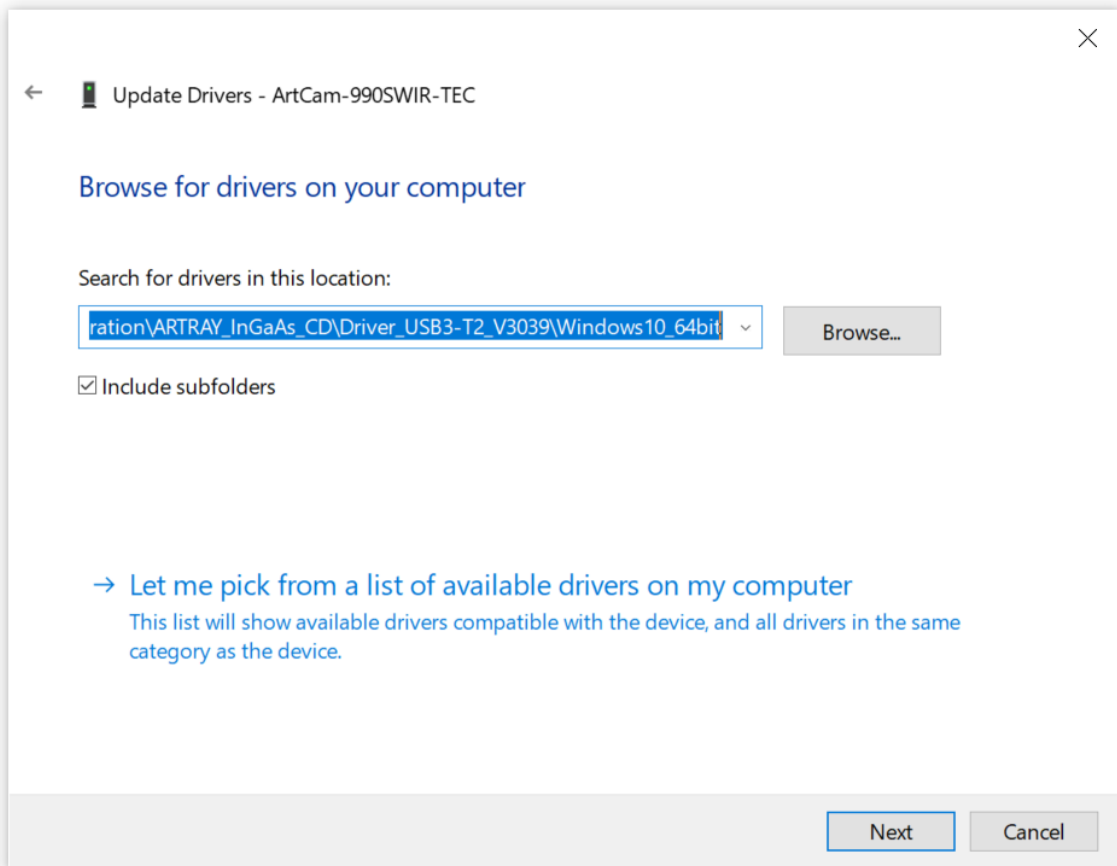

**Include subfolders, then click Next.**

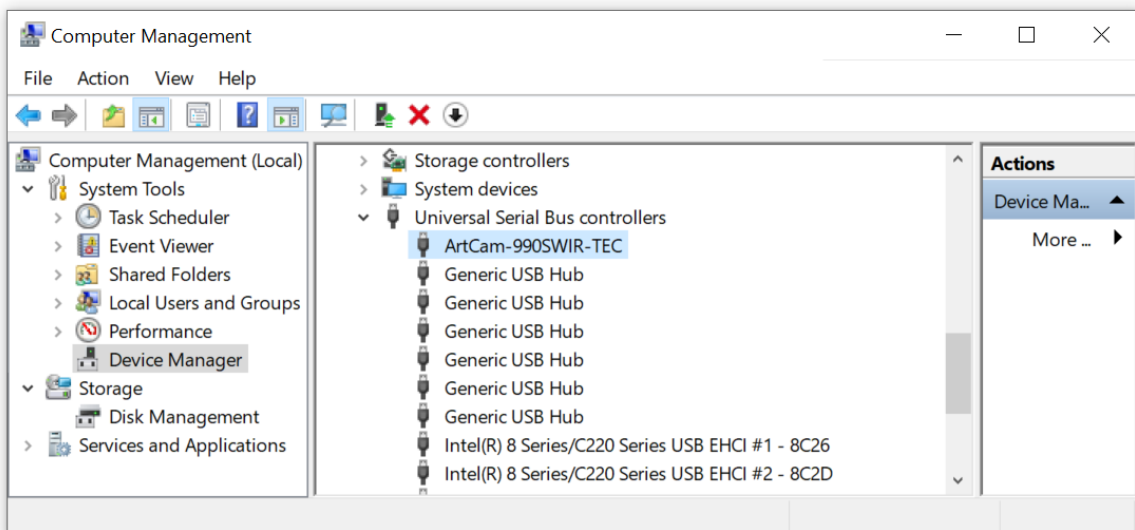
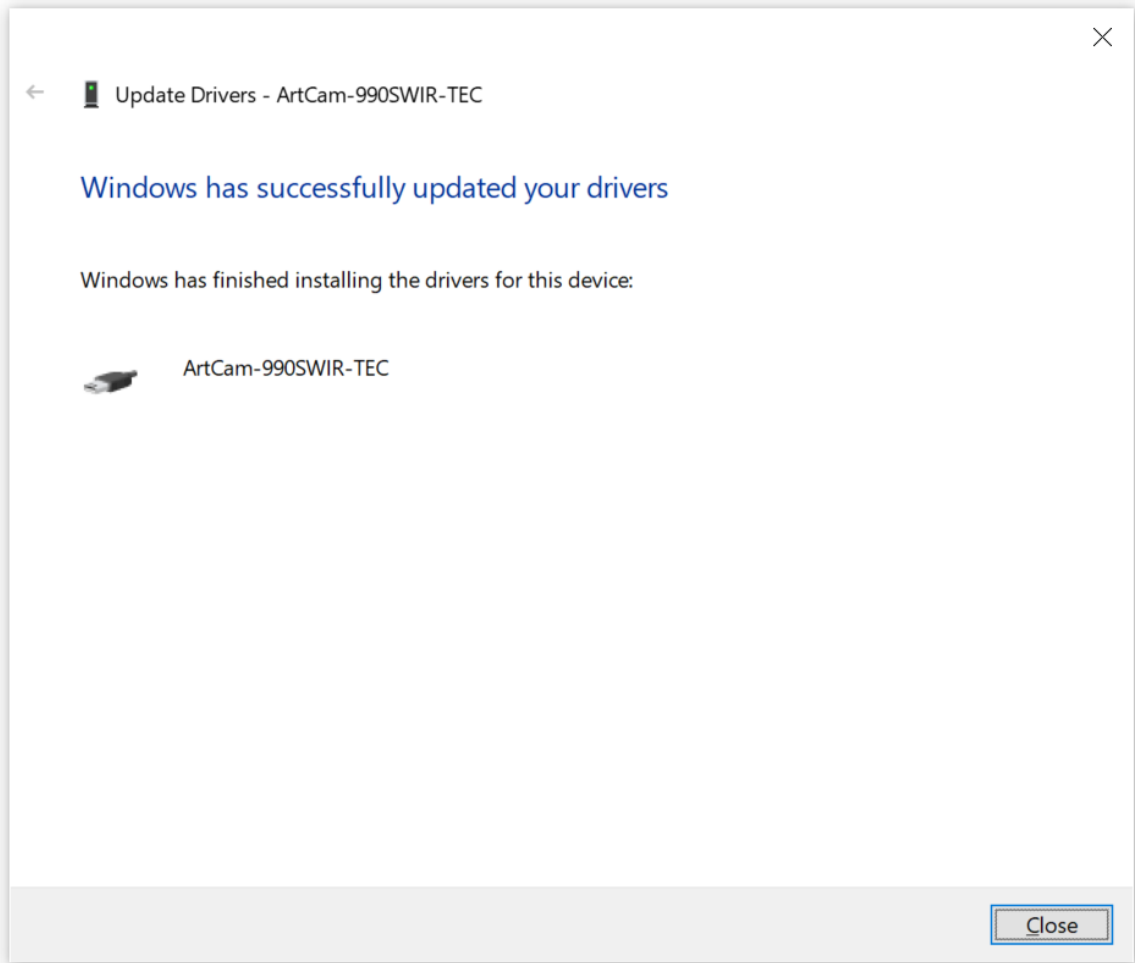

The camera will appear as a Universal Serial Bus controle.

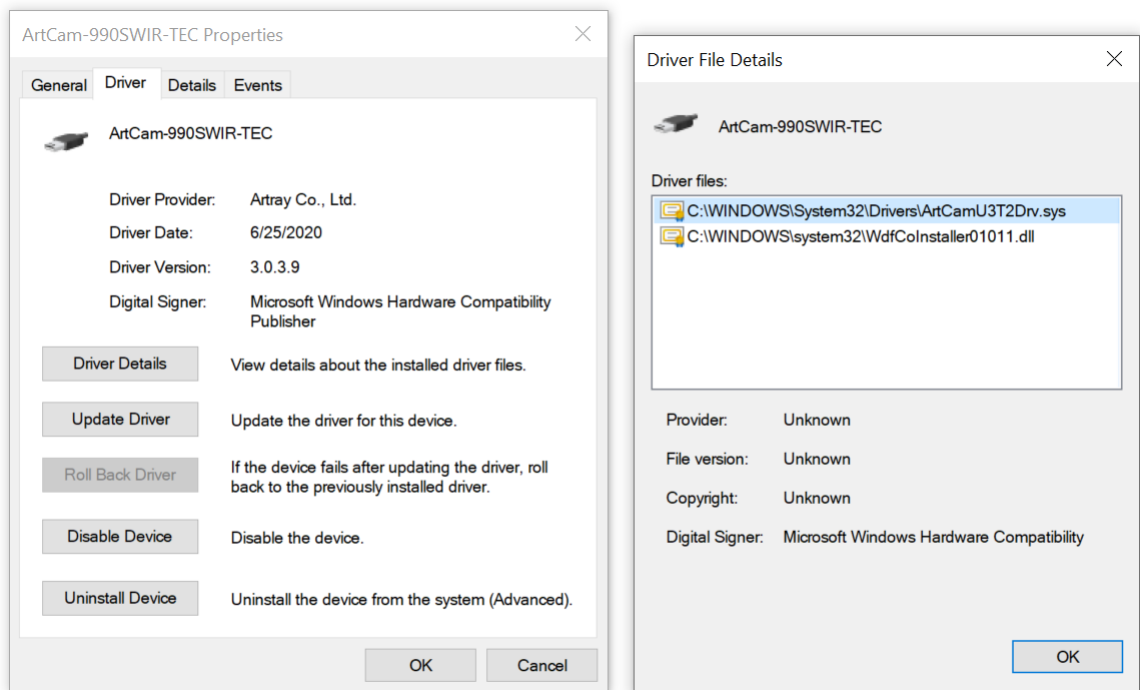

Details about the installed driver.

## 22.12.2 Artray ARTCAM-990 SWIRTEC - Basic setup

Example of running the ARTCAM 990SWIRTEC

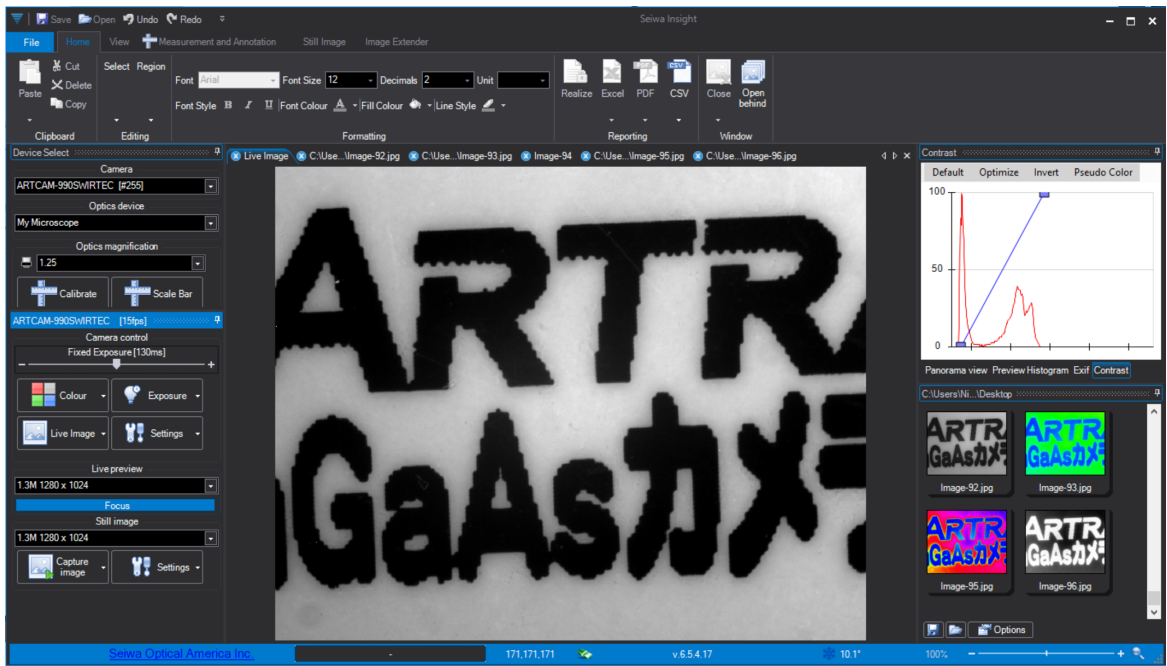

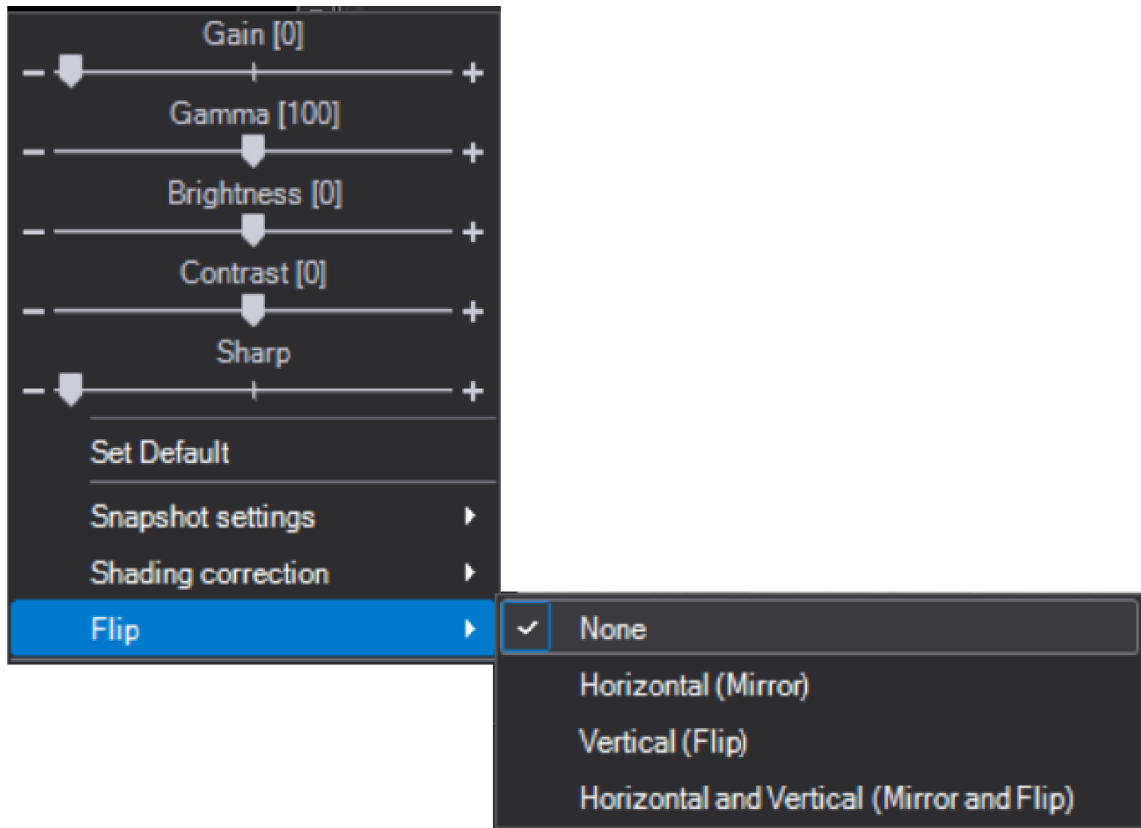

To make the image appear right, select the Flipping = None.

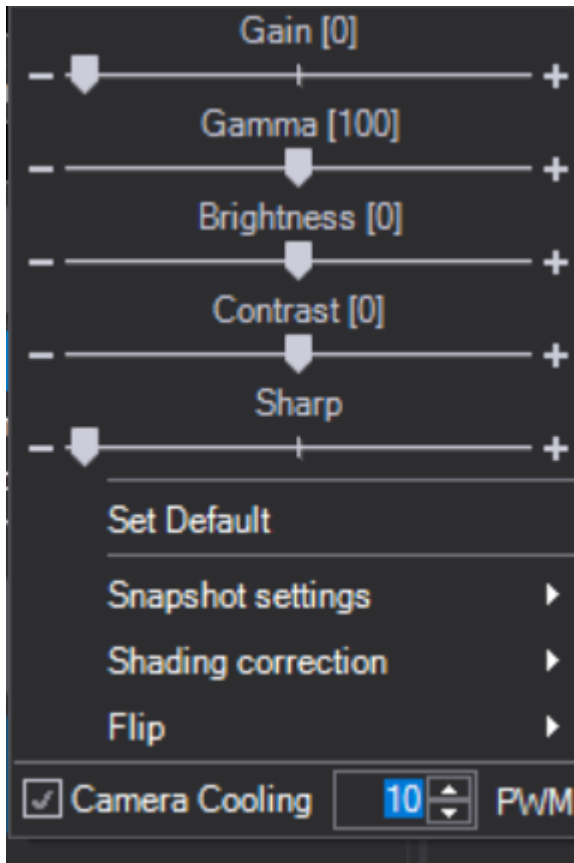

In the Settings, the camera cooling can be enabled by setting a TEC PWM value greater than zero.

The maximum PWM value is 80. A value of 20-30 will effectively cool the camera.

## 22.13 Allied Vision - GOLDEYE

A set of Allied Vision cameras are integrated:

- GOLDEYE G-032
- Goldeye-033 SWIR TEC1
- Mako G-040B
- Goldeye G-030

These cameras are for special purposes, as example: The Goldeye G-032 TEC1 is a shortwave infrared camera for the spectral range from 900nm to 1700nm.

High frame rates of 100 fps at full resolution (636 x 508), strong sensor cooling, as well as a high intra-scene dynamic range of more than 73 dB enable to apply the camera in various application areas and under varying operating conditions.

Note: These cameras requires a special DeltaPix InSight dongle bit.

## Contrast setting

For this camera the contrast can be set using an interactive histogram tool:  
The tool shows in the tabbed control, along with the "Panorama View".

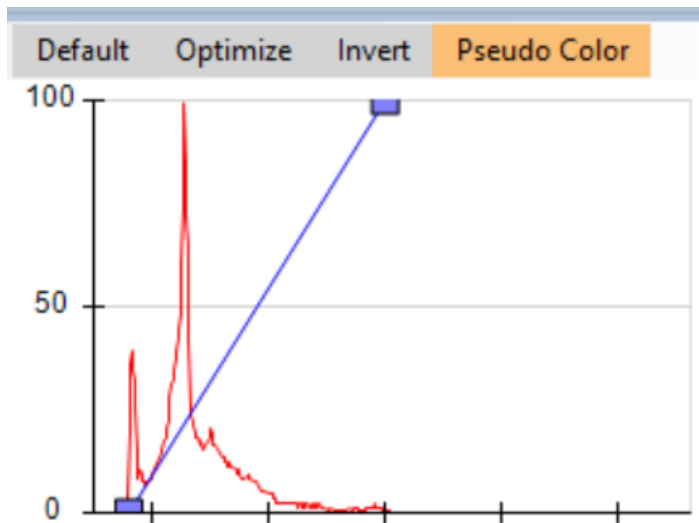

The live preview histogram is shown (the red curve) along with a line - defined by (mouse movable endpoints).  
The line defines the linear LUT transfer function.

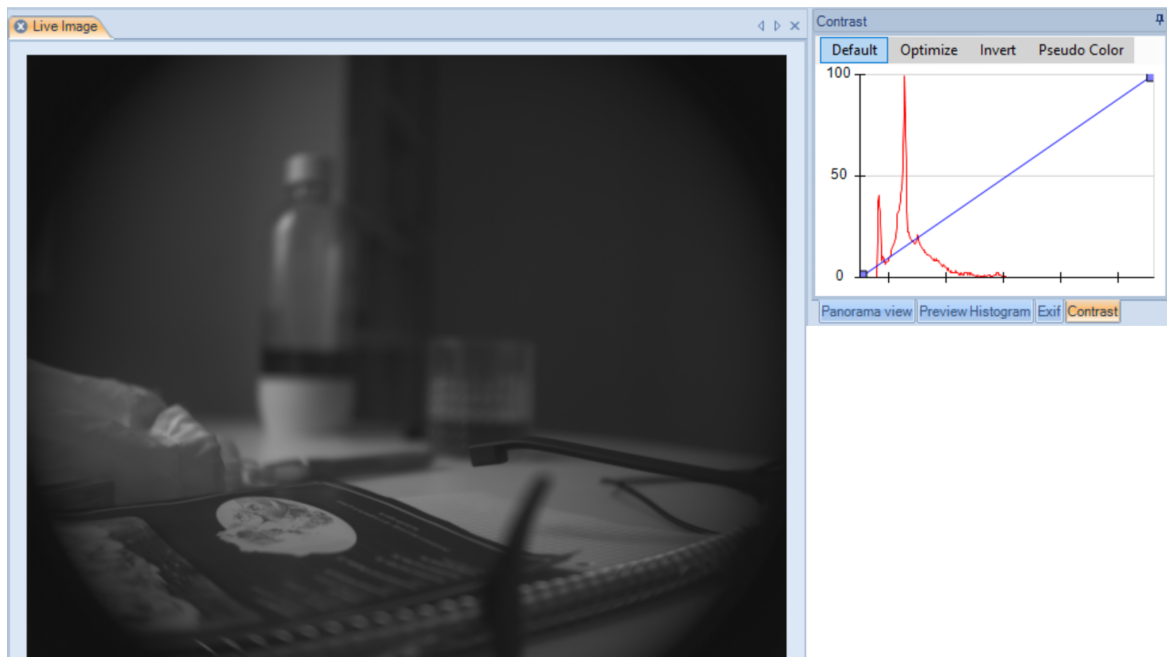

The default 1:1 view.



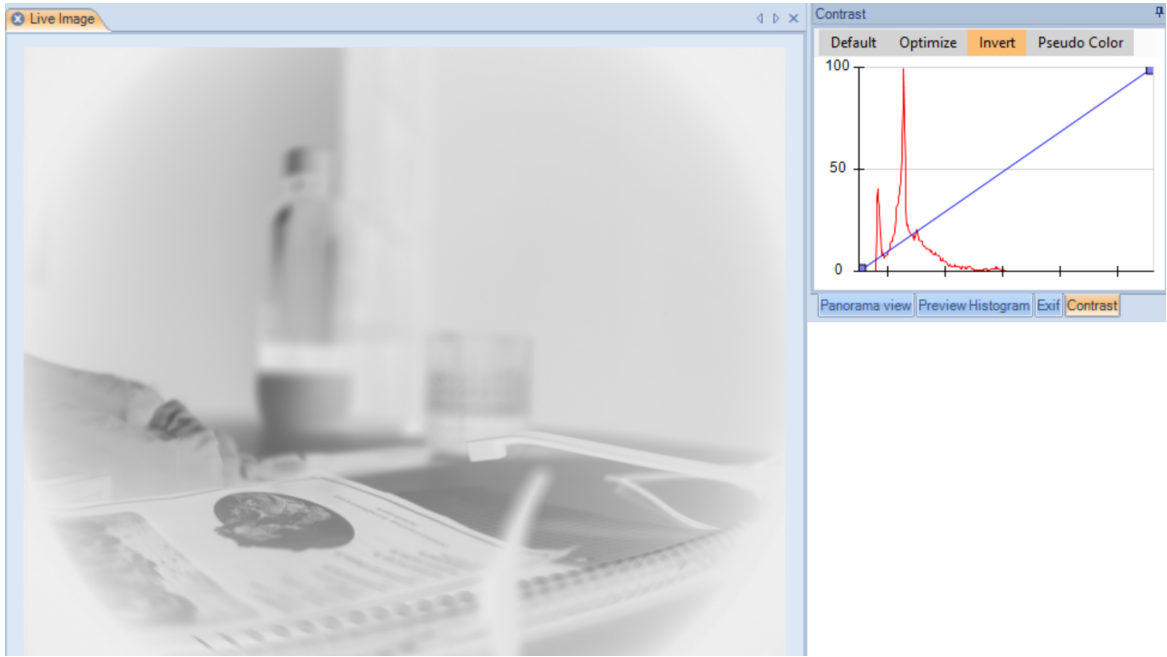

Inverted 1:1 view

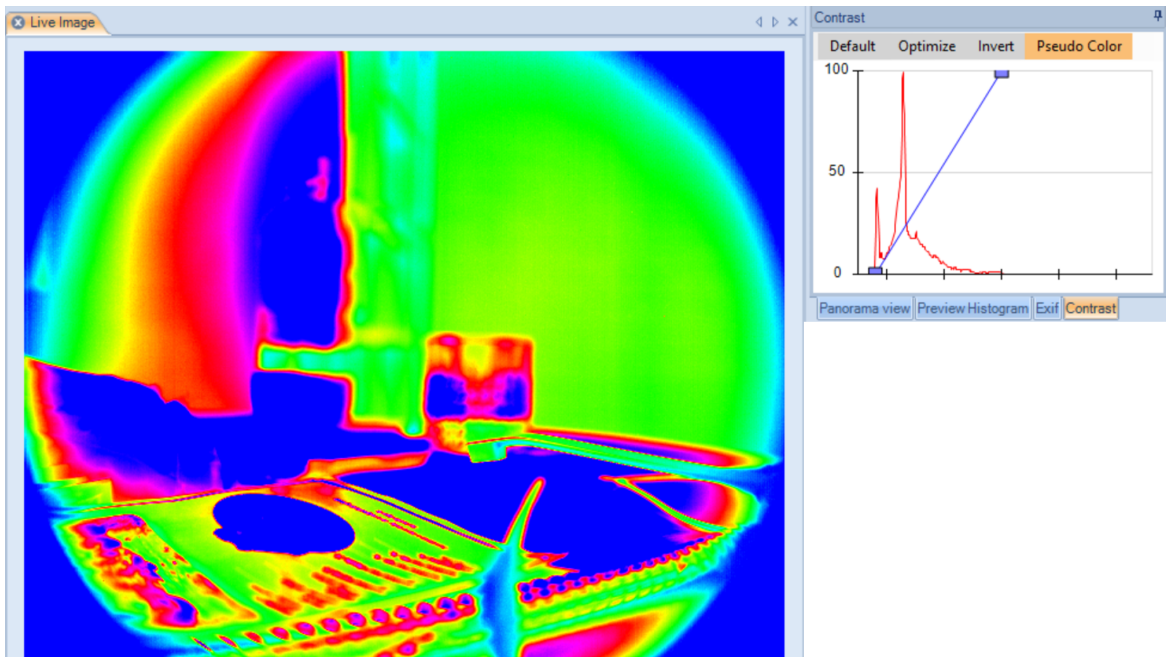

Contrast enhanced view with optional pseudo coloring. Contrast adjustment by dragging line.

### Parameter setting

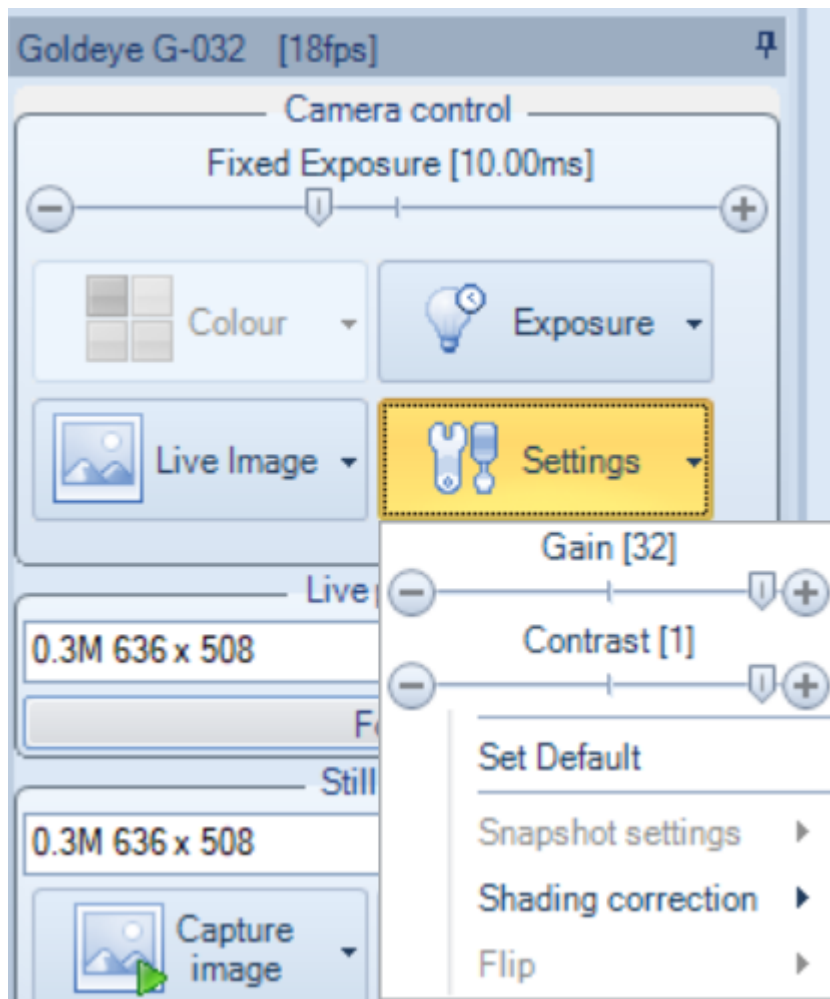

The GOLDEYE only has gain 1 or 32, Auto-contrast OFF or ON.

## 22.14 Connecting H4KWSD08DPX by WiFi



Make sure that you have at least v2.8  
Attach network adapter to the USB3 port.

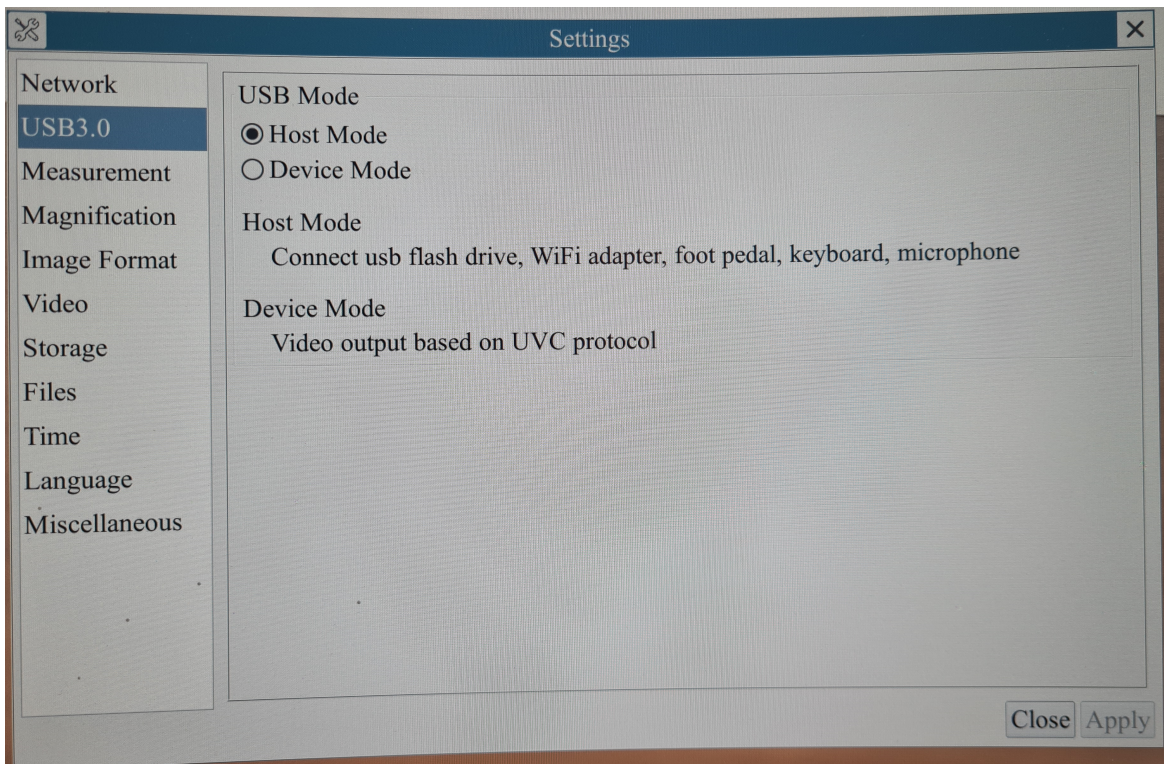

In the settings, select "Host Mode".

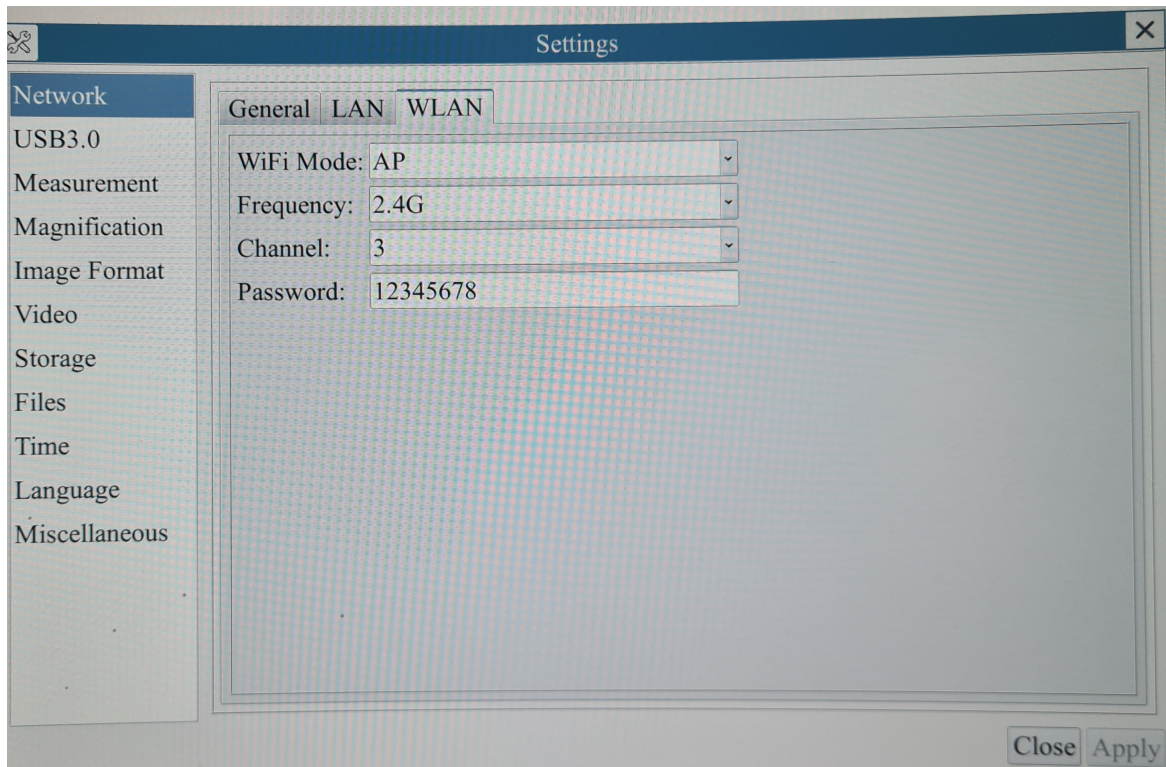

Depending on your network select 2.4G or 5G (recommended 2.4G)

## 22.15 TEKLEAD Scanner

Bar code scanners can be used to identify fixed objectives or click stops. The 1D or 2D code should contain the number of the objective, objectives ordered from 1 - N, where 1 selects the 1st objective.

Example: The code should contain the "<3>" string to select objective #3,

**Note: Objectives must be labeled from 1, and in the same order as defined in the optics editor.**

Barcodes can be generated on-line, e.g. by <https://barcode.tec-it.com/en/QRCode>

Sample 2D codes:



<1>



<2>



<3>



<4>



<5>



<6>



### 22.15.1 TEK\_E1\_CCD

To set the TEK\_E1\_CCD into VCOM mode, scan the code here:



USB-COM

### 22.15.2 TEK\_E2\_USB

To set the TEK\_E2\_USB into VCOM mode, scan the code here:



USBCDC

# Index

## - E -

ErgoControl 150